

HITACHI

KAOHSIUNG HITACHI
ELECTRONICS CO.,LTD
P.O. BOX 26-27
2,13TH EAST ST. K.E.P.Z.
KAOHSIUNG TAIWAN R.O.C.
TEL:(07) 8215811 (7 LINE)
FAX:(07) 8215815

FOR MESSRS : _____

DATE: Sep.11,2009

CUSTOMER'S ACCEPTANCE SPECIFICATIONS

LMG7420PLFC-X

C O N T E N T S

No.	ITEM	SHEET No.	PAGE
1	COVER	7B64PS 2701- LMG7420PLFC-X-8	1-1/1
2	RECORD OF REVISION	7B64PS 2702- LMG7420PLFC-X-8	2-1/2~2/2
3	GENERAL SPECIFICATION	7B64PS 2703- LMG7420PLFC-X-8	3-1/1
4	ABSOLUTE MAXIMUM RATINGS	7B64PS 2704- LMG7420PLFC-X-8	4-1/1
5	ELECTRICAL CHARACTERISTICS	7B64PS 2705- LMG7420PLFC-X-8	5-1/1
6	OPTICAL CHARACTERISTICS	7B64PS 2706- LMG7420PLFC-X-8	6-1/2~2/2
7	BLOCK DIAGRAM	7B64PS 2707- LMG7420PLFC-X-8	7-1/1
8	INTERFACE TIMING	7B64PS 2708- LMG7420PLFC-X-8	8-1/2~2/2
9	OUTLINE DIMENSIONS	7B63PS 2709- LMG7420PLFC-X-8 7B64PS 2709- LMG7420PLFC-X-8	9-1/3 9-2/3~3/3
10	APPEARANCE STANDARD	7B64PS 2710- LMG7420PLFC-X-8	10-1/5~5/5
11	PRECAUTION IN DESIGN	7B64PS 2711- LMG7420PLFC-X-8	11-1/2~2/2
12	DESIGNATION OF LOT MARK	7B64PS 2712- LMG7420PLFC-X-8	12-1/1
13	PRECAUTION FOR USE	7B64PS 2713- LMG7420PLFC-X-8	13-1/1

* When product will be discontinued , customer will be informed by HITACHI with twelve months prior to discontinuation.

ACCEPTED BY: _____

PROPOSED BY: *Elton Liu*

KAOHSIUNG HITACHI ELECTRONICS CO.,LTD.	Sh. No.	7B64PS 2701-LMG7420PLFC-X-8	PAGE	1-1/1
---	------------	-----------------------------	------	-------

RECORD OF REVISION

DATE	SHEET No.	SUMMARY																
Feb.10,'95	7B64PS 2704- LMG7420PLFC-X-2 PAGE 4-1/1	CHANGED : <table border="1" style="margin-left: 20px; width: 80%;"> <thead> <tr> <th rowspan="2">ITEM</th> <th colspan="2">OPERATING</th> </tr> <tr> <th>MIN</th> <th>MAX</th> </tr> </thead> <tbody> <tr> <td>AMBIENT TEMPERATURE</td> <td>0°C</td> <td>40°C</td> </tr> </tbody> </table> <table border="1" style="margin-left: 20px; width: 80%;"> <thead> <tr> <th rowspan="2">ITEM</th> <th colspan="2">OPERATING</th> </tr> <tr> <th>MIN</th> <th>MAX</th> </tr> </thead> <tbody> <tr> <td>AMBIENT TEMPERATURE</td> <td>0°C</td> <td>50°C</td> </tr> </tbody> </table>	ITEM	OPERATING		MIN	MAX	AMBIENT TEMPERATURE	0°C	40°C	ITEM	OPERATING		MIN	MAX	AMBIENT TEMPERATURE	0°C	50°C
	ITEM	OPERATING																
MIN		MAX																
AMBIENT TEMPERATURE	0°C	40°C																
ITEM	OPERATING																	
	MIN	MAX																
AMBIENT TEMPERATURE	0°C	50°C																
	7B64PS 2705- LMG7420PLFC-X-2 PAGE 5-1/2	CHANGED : <table border="1" style="margin-left: 20px; width: 80%;"> <thead> <tr> <th></th> <th>CONDITION</th> <th>TYP.</th> </tr> </thead> <tbody> <tr> <td>VDD-V0</td> <td>Ta=40°C, φ=10°C</td> <td>15.4</td> </tr> </tbody> </table> <table border="1" style="margin-left: 20px; width: 80%;"> <thead> <tr> <th></th> <th>CONDITION</th> <th>TYP.</th> </tr> </thead> <tbody> <tr> <td>VDD-V0</td> <td>Ta=50°C, φ=10°C</td> <td>15.2</td> </tr> </tbody> </table>		CONDITION	TYP.	VDD-V0	Ta=40°C, φ=10°C	15.4		CONDITION	TYP.	VDD-V0	Ta=50°C, φ=10°C	15.2				
	CONDITION	TYP.																
VDD-V0	Ta=40°C, φ=10°C	15.4																
	CONDITION	TYP.																
VDD-V0	Ta=50°C, φ=10°C	15.2																
MAR.30,'99	7B64PS 2709- LMG7420PLFC-X-3 PAGE 9-1/3	CHANGED : CABLE'S LENGTH & LOCATION																
JUL.07,'99	7B64PS 2706- LMG7420PLFC-X-4 PAGE 6-2/2	6.2 OPTICAL CHARACTERISTICS OF BACKLIGHT. BRIGHTNESS (TYP.) CHANGED 40 → 90 (TYPING ERROR REV.3) RISE TIME (TYP.) CHANGED 20 → 5 (TYPING ERROR REV.3)																
	7B64PS 2707- LMG7420PLFC-X-4 PAGE 7-1/1	7. BLOCK DIAGRAM ALL PAGE CHANGED (TYPING ERROR REV.3)																
Feb.14,'05	7B64PS 2703- LMG7420PLFC-X-5 PAGE 3-1/1	Added : (10) CFL LIFETIME 50Khrs																
	7B64PS 2705- LMG7420PLFC-X-5 PAGE 5-1/1	5.2 ELECTRICAL CHARACTERISTICS OF BACKLIGHT THE NOTE. 4.5 ADDED																
	7B64PS 2706- LMG7420PLFC-X-5 PAGE 6-2/2	Changed : 6.2 OPTICAL CHARACTERISTICS OF BACKLIGHT. BRIGHTNESS MIN. 70.0 → 100.0 TYP. 90.0 → 150.0																

RECORD OF REVISION

DATE	SHEET No.	SUMMARY								
May.28,'07	7B64PS 2709- LMG7420PLFC-X-6 PAGE 9-3/3	9.3 Internal Pin Connection Changed : CFL I / F : Mitsumi M63M83 - 04 → JAE IL-G-4S-S3C2-SA								
	7B64PS 2712- LMG7420PLFC-X-6 PAGE 12-1/1	12. DESIGNATION OF LOT MARK Added <table border="1" style="margin-left: 20px; border-collapse: collapse; width: 80%;"> <thead> <tr> <th style="width: 15%;">REV No.</th> <th style="width: 55%;">ITEM</th> <th style="width: 30%;">LOT No.</th> </tr> </thead> <tbody> <tr> <td style="text-align: center;">A</td> <td>CCFL tube diameter ($\phi 2.6 \rightarrow \phi 2.4$)</td> <td style="text-align: center;">-</td> </tr> <tr> <td style="text-align: center;">B</td> <td>CFL I/F Connector : Mitsumi M63M83-04 → JAE IL-G-4S-S3C2-SA</td> <td style="text-align: center;">7102T</td> </tr> </tbody> </table>	REV No.	ITEM	LOT No.	A	CCFL tube diameter ($\phi 2.6 \rightarrow \phi 2.4$)	-	B	CFL I/F Connector : Mitsumi M63M83-04 → JAE IL-G-4S-S3C2-SA
REV No.	ITEM	LOT No.								
A	CCFL tube diameter ($\phi 2.6 \rightarrow \phi 2.4$)	-								
B	CFL I/F Connector : Mitsumi M63M83-04 → JAE IL-G-4S-S3C2-SA	7102T								
Jul.24,'07	7B64PS 2712- LMG7420PLFC-X-7 PAGE 12-1/1	12. DESIGNATION OF LOT MARK Added : REV No. C								
Sep.11,'09	7B64PS 2712- LMG7420PLFC-X-8 PAGE 12-1/1	12. DESIGNATION OF LOT MARK Added <table border="1" style="margin-left: 20px; border-collapse: collapse; width: 80%;"> <thead> <tr> <th style="width: 15%;">REV No.</th> <th style="width: 55%;">ITEM</th> <th style="width: 30%;">LOT No.</th> </tr> </thead> <tbody> <tr> <td style="text-align: center;">D</td> <td>Controller IC (RA6963)</td> <td style="text-align: center;">-</td> </tr> </tbody> </table>	REV No.	ITEM	LOT No.	D	Controller IC (RA6963)	-		
REV No.	ITEM	LOT No.								
D	Controller IC (RA6963)	-								

3. GENERAL SPECIFICATIONS

(1) Part Name	LMG7420PLFC-X
(2) Module Size	159.4(W)mm x 101.0(H)mm x 11.0(D)mm max.
(3) Dot Size	0.47(W)mm x 0.47(H)mm
(4) Dot Pitch	0.50(W)mm x 0.50(H)mm
(5) Number Of Dots	240(W) x 128(H)dots
(6) Duty	1/128
(7) LCD Type	Film type black / white (Negative type) The upper polarizer is anti-glare type. (Hardness.3H) The bottom polarizer is transmissive type.
(8) Viewing Direction	6 O'clock
(9) Backlight	Cold cathode fluorescent lamp
(10) CFL Lifetime	50k hrs.

4. ABSOLUTE MAXIMUM RATINGS

4.1 Electrical Absolute Maximum Ratings.

VSS = 0V : Standard

ITEM	SYMBOL	MIN.	MAX.	UNIT	COMMENT
Power Supply For Logic	VDD-VSS	0	6.5	V	
Power Supply For LC Drive	VDD-VEE	0	20.5	V	
Input Voltage	Vi	-0.3	VDD+0.3	V	
Input Current	li	0	1	A	
Static Electricity	-	-	-	-	(Note 1)

Note 1 : Make certain you are grounded when handling LCM.

4.2 Environmental Absolute Maximum Ratings

ITEM	OPERATING		STORAGE		COMMENT
	MIN.	MAX.	MIN.	MAX.	
Ambient Temperature	0°C	50°C	-20°C	60°C	(Note 2,3)
Humidity	(Note 1)		(Note 1)		Without Condensation
Vibration	-	4.9m/s ² (0.5G)	-	19.6m/s ² (2G) (Note 5)	(Note 4)
Shock	-	29.4m/s ² (3G)	-	490.0m/s ² (50G)	XYZ Directions
Corrosive Gas	Not Acceptable		Not Acceptable		

Note 1 : Ta ≤ 40°C : 85%RH max.

Ta > 40°C : Absolute humidity must be lower than the humidity of 85%RH at 40°C

Note 2 : Ta at -20°C — < 48h, at 60°C — < 168h.

Note 3 : Background color changes slightly depending on ambient temperature.

This phenomenon is reversible.

Higher starting voltage of CFL and higher LCD driving voltage are needed while operating at 0°C.

The life time of CFL will be reduced while operating at 0°C. Need to make sure the value of IL and characteristics of inverter.

Also the response time at 0°C will be slower.

Note 4 : 5Hz~100Hz (Except Resonance Frequency)

Note 5 : This module should be operated normally after finishing the test.

5. ELECTRICAL CHARACTERISTICS

5.1 ELECTRICAL CHARACTERISTICS

ITEM	SYMBOL	CONDITION	MIN.	TYP.	MAX.	UNIT
Power Supply Voltage For Logic	VDD-VSS	-	4.75	5.0	5.25	V
LC driver Circuit Power Supply Voltage	VEE-VSS	-	-15.5	-15.0	-14.5	V
Input Voltage	VI	H LEVEL	0.8VDD	-	VDD	V
		L LEVEL	0	-	0.2VDD	V
Power Supply Current For Logic (Note 1)	IDD	VDD-VSS=5.0V	-	11.7	14.0	mA
Power Supply Current For LCD (Note 1)	IEE	VDD-VSS=5.0V	-	2.5	4.0	mA
Recommended LC Driving Voltage (Note 2)	VDD-V0	Ta= 0°C , $\phi = 0^\circ$	-	16.9	-	V
		Ta=25°C , $\phi = 0^\circ$	-	15.8	-	V
		Ta=50°C , $\phi = 0^\circ$	-	15.2	-	V

Note 1 : VDD-V0=15.8V , Ta=25°C

Note 2 : Recommended LC driving voltage may fluctuate about $\pm 1.0V$ by each module.
Test pattern is all "Q".

5.2 ELECTRICAL CHARACTERISTICS OF BACKLIGHT

ITEM	SYMBOL	MIN.	TYP.	MAX.	UNIT	NOTE
Lamp Voltage	VL	-	360	-	Vrms	Ta=25°C
Frequency	fL	30	70	85	kHz	Ta=25°C
Lamp Current	IL	2.5	5	5.5	mArms	Ta=25°C
Starting Discharge Voltage	VS (Note 2)	(1000)	-	-	Vrms	Ta=25°C

Please certainly inform HITACHI before designing lamp drive circuit according to the above specifications.

Note 1 : Please make sure that your inverter is designed to meet the above specifications.

Note 2 : Starting discharge voltage is increased when LCM is operating at lower temperature.
Please check the characteristics of your inverter before applying to your set.

Note 3 : Average life time of CFL will be decreased when LCM is operating at lower temperature.

Note 4 : Under lower driving frequency of an inverter , a certain backlight system (CFL & CFL reflection sheet) may generate a sound noise.

Note 5 : When IL is used over 5.5mA , it may cause uneven contrast near CFL location , due to heat dispersion from CFL.

6. OPTICAL CHARACTERISTICS

6.1 OPTICAL CHARACTERISTICS

Ta=25°C (Backlight on)

ITEM	SYMBOL	CONDITIONAL	MIN.	TYP.	MAX.	UNIT	NOTE
Viewing Area	$\phi 2-\phi 1$	$K \geq 2.0$	30	40	-	deg	1,2
Contrast Ratio	K	$\phi = 0^\circ, \theta = 0^\circ$	-	20	-	-	3
Response Time (Rise)	tr	$\phi = 0^\circ, \theta = 0^\circ$	-	(160)	-	ms	4
Response Time (Fall)	tf	$\phi = 0^\circ, \theta = 0^\circ$	-	(110)	-	ms	4

(Measure condition by HITACHI)

Note 1 : Definition of θ and ϕ

Note 3 : Definition of contrast "K"

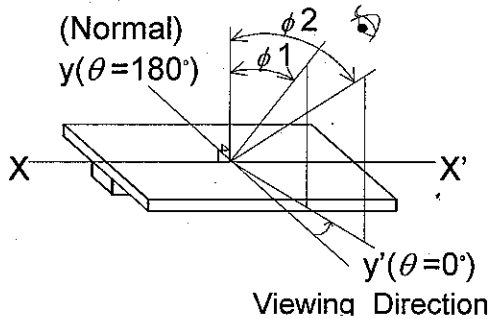

$$K = \frac{\text{Brightness on selected dot (B1)}}{\text{Brightness on non-selected dot (B2)}}$$

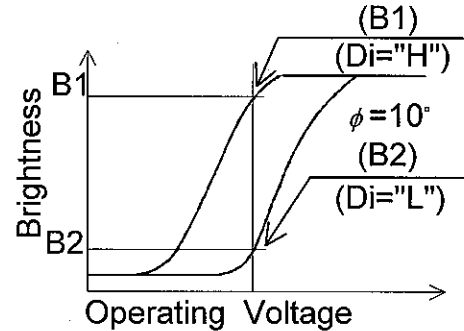

Note 2 : Definition of viewing angle $\phi 1$ and $\phi 2$.

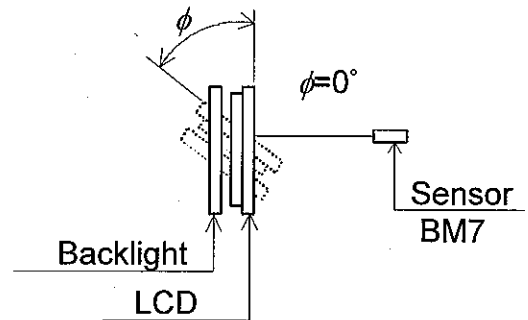
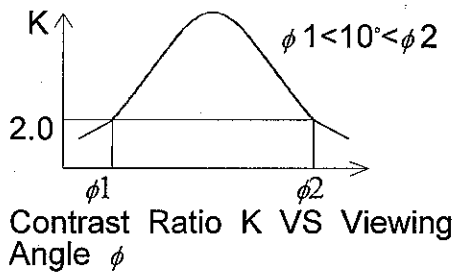

Note 4 : Definition of optical response

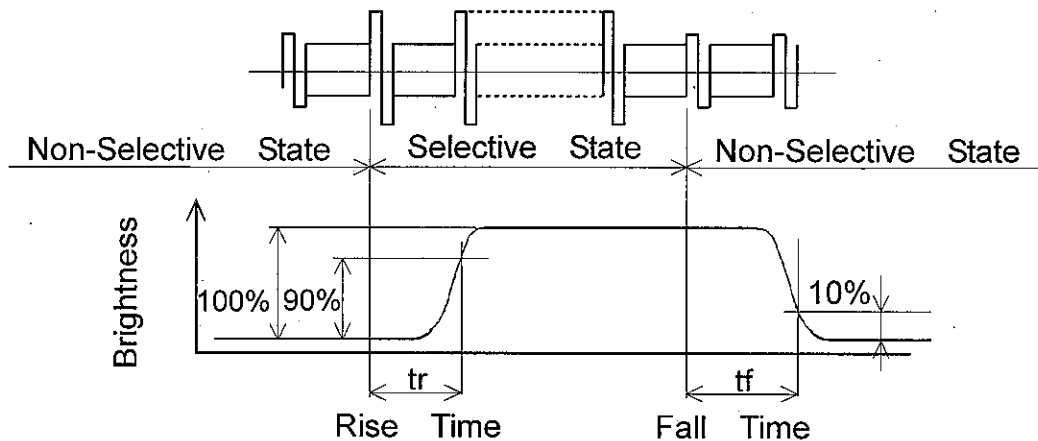

6.2 OPTICAL CHARACTERISTICS OF BACKLIGHT

ITEM	MIN.	TYP.	MAX.	UNIT	NOTE
Brightness	(120)	150	-	cd/m ²	IL=5mA (Note 1,2)
Rise Time	-	5	-	Minute	IL=5mA Brightness 80%
Brightness Uniformity	-	-	±30	%	Undermentioned (Note 1,3)

CFL : Initial, Ta=25°C, VDD-V0=15.8V
Display data should be all "ON".

Note 1 : Measurement after 10 minutes of CFL operating.

Note 2 : Brightness control : 100%

Note 3 : Measure of the following 9 places on the display.

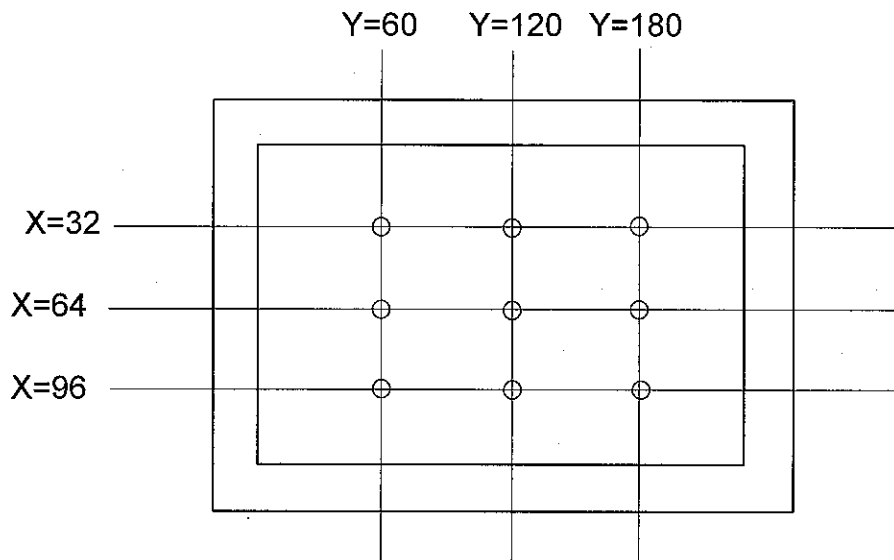

Definition of the brightness tolerance.

$$\left(\frac{\text{Max. or min. Brightness} - \text{Average Brightness}}{\text{Average Brightness}} \right) \times 100$$

7. BLOCK DIAGRAM

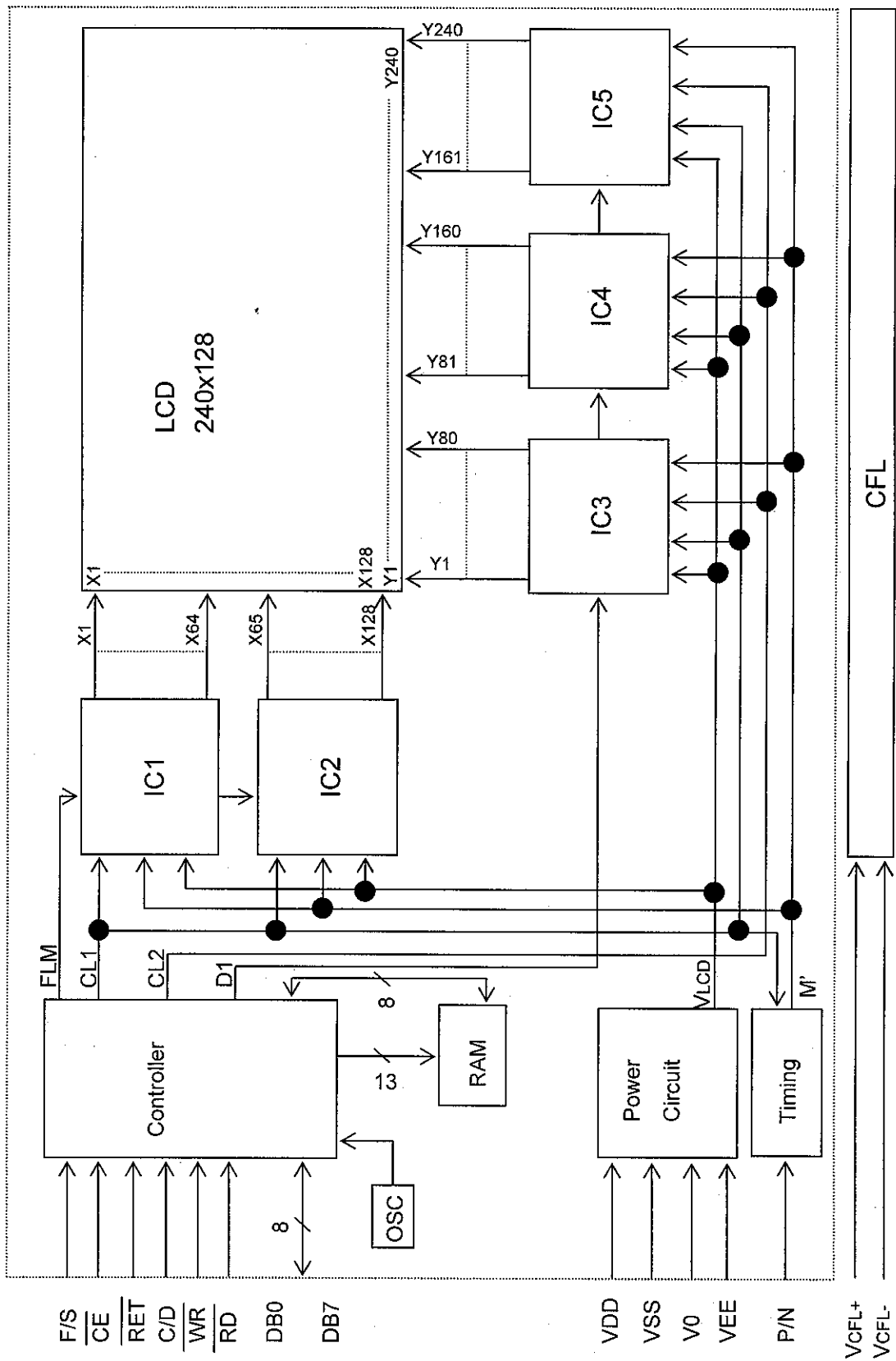

8. INTERFACE TIMING

8.1 INTERFACE TIMING

ITEM	SYMBOL	MIN.	TYP.	MAX.	UNIT
C/D Setup Time	tCDS	100	-	-	ns
C/D Hold Time	tCDH	10	-	-	ns
CE, RD, WR Pulse Width	tCE, tRD, tWR	80	-	-	ns
Data Setup Time	tDS	80	-	-	ns
Data Hold Time	tDH	40	-	-	ns
Access Time	tACC	-	-	150	ns
Output Hold Time	tOH	10	-	50	ns

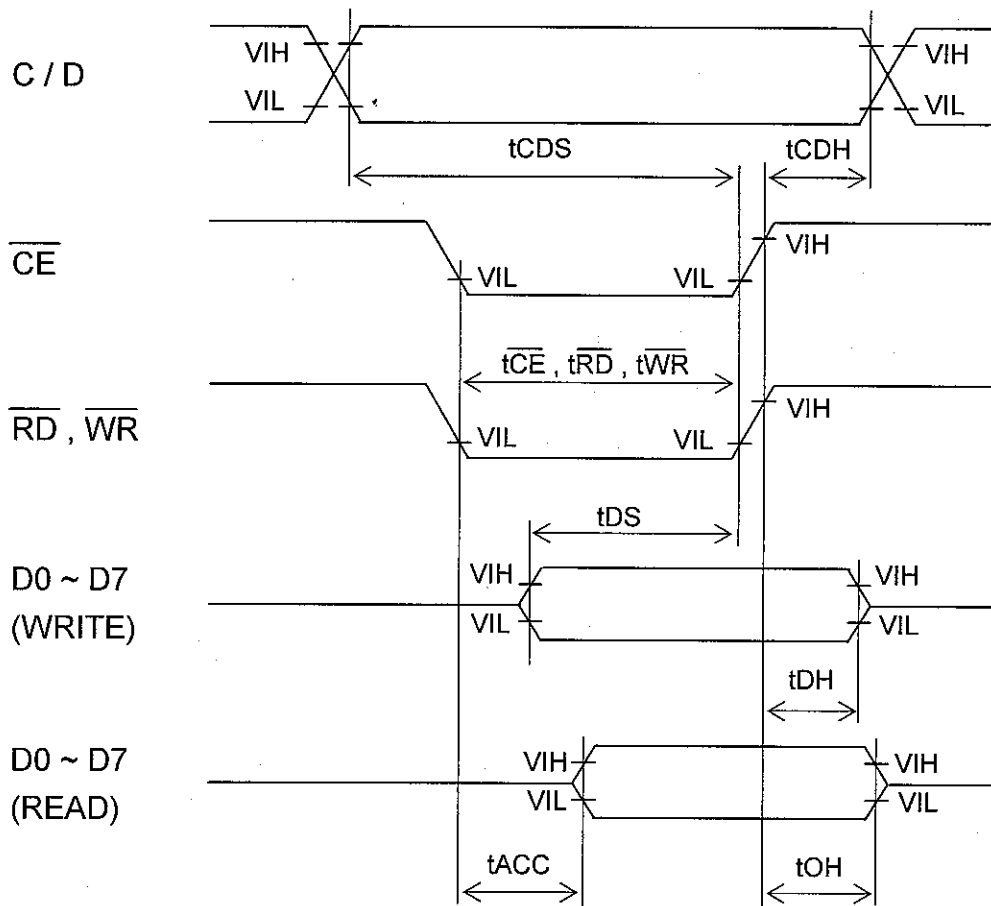

8.2 TIMING OF POWER SUPPLY AND INTERFACE SIGNAL

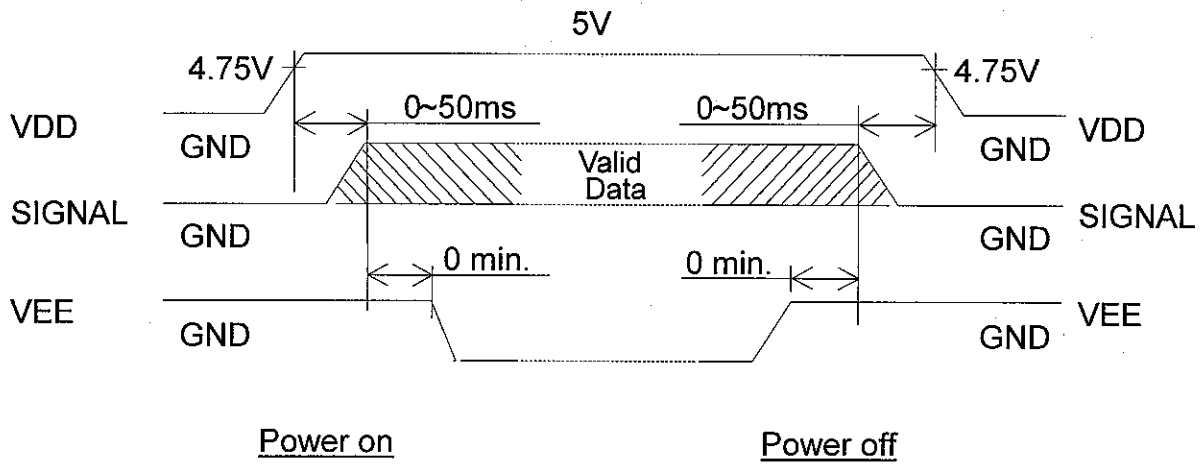

The missing pixels may occur when the LCM is driven beyond above power interface timing sequence.

8.3 POWER SUPPLY FOR LCM (EXAMPLE)

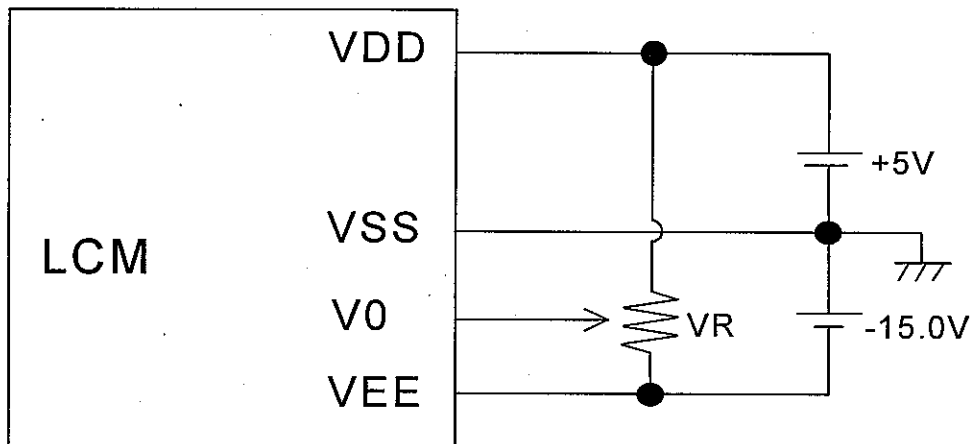

Recommend:

VR: 10~20k Ω

VDD-V0 : LCD driving voltage

9.2 DISPLAY PATTERN

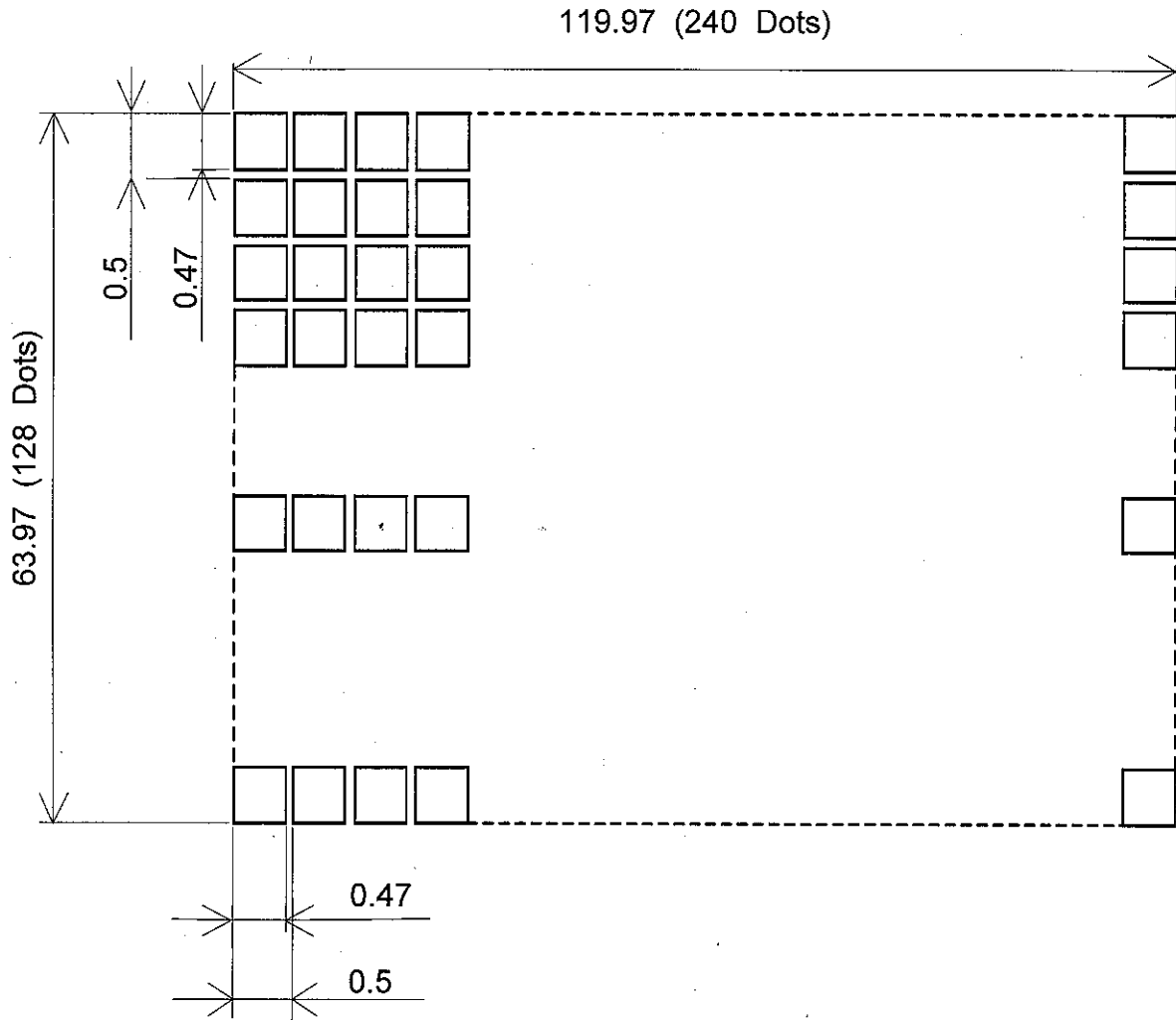

Scale: NTS

Unit : mm

Measurement Tolerance : ± 0.1

9.3 INTERNAL PIN CONNECTION

CN1

PIN No.	SYMBOL	FUNCTION
A1	VSS(0V)	Ground
A2	VDD(+5V)	Power supply for logic circuit
A3	V0	Power supply for LCD drive
A4	C/D	\overline{WR} ="L" : C/D="H" Command write C/D="L" Data write \overline{RD} ="L" : C/D="H" Status read C/D="L" Data read
A5	\overline{WR}	Data write (Data write at "L")
A6	\overline{RD}	Data read (Read data at "L")
A7~14	DB0~DB7	Data bus
A15	\overline{CE}	Chip enable (\overline{CE} must be "L")
A16	\overline{RET}	Reset
A17	VEE(-15V)	Power supply for LCD drive
A18	$\overline{D.OFF}$	NC/Display , GND/Display off
A19	F/S	Character font select : F/S="H" 6*8Font F/S="L" 8*8Font
A20	P/N	Display mode reverse.

CN2

INTERFACE		PIN No.	SYMBOL	LEVEL	FUNCTION
CFL	CFL I/F	1	GND	-	CFL ground
		2	N.C	-	No connection
		3	N.C	-	No connection
		4	H.V	-	Power supply for CFL

CFL I/F : JAE IL-G-4S-S3C2-SA

10. APPEARANCE STANDARD

10.1 APPEARANCE INSPECTION CONDITION

Visual inspection should be done under the following condition.

- (1) In the dark room
- (2) With CFL panel lighted with prescribed inverter circuit.
- (3) With eyes 25cm distance from LCM.
- (4) Viewing angle within 45 degrees from the vertical line to the center of LCD.

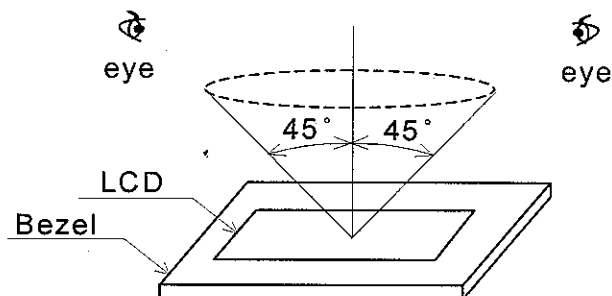

10.2 DEFINITION OF EACH ZONE

A zone : Within the effective display area specified at page 9-1/3 of this document.

B zone : Area between the window of bezel line and the effective display area line specified at page 9-1/3 of this document.

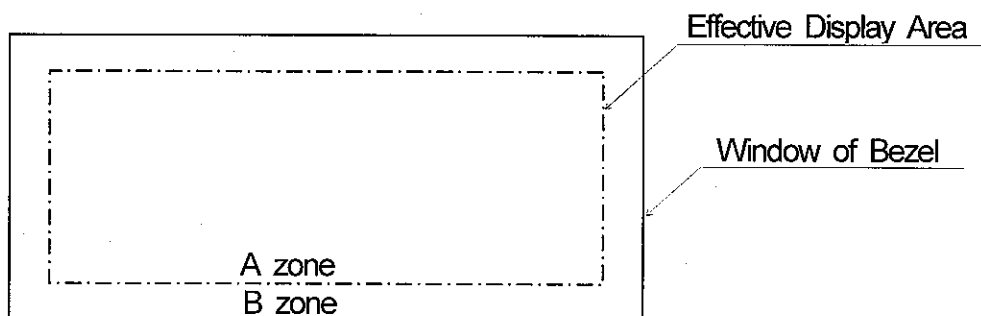

10.3 APPEARANCE SPECIFICATION

(1) LCD appearance

*) If the problem occurs about this item, the responsible person of both party (customer and HITACHI) will discuss more detail.

No.	ITEM	CRITERIA			A	B	
L C D	Scratches	Distinguished One Is Not Acceptable (To be judged by HITACHI standard)			*	-	
	Dent	Same as above			*	-	
	Wrinkles In Polarizer	Same as above			*	-	
	Bubbles	Average Diameter D(mm)		Maximum Number Acceptable		0	-
		D ≤ 0.2		Ignored			
		0.2 < D ≤ 0.3		12			
		0.3 < D ≤ 0.5		3			
		0.5 < D		None			
	Stains, Foreign Materials Dark spot	Filamentous			0	*	
		LENGTH L(mm)	Width W(mm)	Maximum Number Acceptable			
		L ≤ 2.0	W ≤ 0.03	Ignored			
		L ≤ 3.0	0.03 < W ≤ 0.05	6			
		-	0.05 < W	None			
		Round			0	*	
		Average Diameter D(mm)	Maximum Number Acceptable	Minimum Space			
		D < 0.2	Ignored	-			
		0.2 ≤ D < 0.3	6	10 mm			
		0.3 ≤ D < 0.4	4	30 mm			
		0.4 ≤ D	None	-			
		The whole number	Filamentous + Round = 5				
		Those wiped out easily are acceptable			0	0	
Color Tone		To be judged by hitachi standard			0	-	
Color Uniformity	Same as above			0	-		
Pinhole	(A+B)/2 ≤ 0.15 Maximum number : Ignored			0	-		
	0.15 < (A+B)/2 ≤ 0.3 Maximum number : Ignored						
	C ≤ 0.03 Maximum number : Ignored						

No.	ITEM	CRITERIA			A	B
		Average Diameter D(mm)	Contrast	Maximum Number Acceptable		
L	Contrast Irregularity (Spot)	$D \leq 0.25$	To be judged by HITACHI standard	Ignored	-	O -
		$0.25 < D \leq 0.35$		10	20mm	
		$0.35 < D \leq 0.5$		4	20mm	
		$0.5 < D$		None	-	
C D	Contrast Irregularity (A Pair of Scratch)	Width W(mm)	Length L(mm)	Maximum Number Acceptable	Minimum Space	O -
		$W \leq 0.25$	$L \leq 1.2$	2	20mm	
		$W \leq 0.2$	$L \leq 1.5$	3	20mm	
		$W \leq 0.15$	$L \leq 2.0$	3	20mm	
		$W \leq 0.1$	$L \leq 3.0$	4	20mm	
		The whole number		6		
	Rubbing Scratch	To be judged by HITACHI standrd				

(2) CFL BACKLIGHT APPEARANCE

No.	ITEM	CRITERIA			A	B
C F L	Dark Spots	Average Diameter D(mm)	Maximum Number		0	-
	White Spot		Acceptable			
	Foreign Materials (Spot)	$D \leq 0.4$	Ignored			
B A C K L I G H T	Foreign Materials (Line)	Width W(mm)	Length L(mm)	Maximum Number	0	-
		$W \leq 0.2$	$L \leq 2.5$	1		
			$2.5 < L$	None		
	$0.2 < W$	-	None			
L I G H T	Scratches	Width W(mm)	Length L(mm)	Maximum Number	0	-
		$W \leq 0.1$	-	Ignored		
		$0.1 < W \leq 0.2$	$L \leq 11.0$	1		
			$11.0 < L$	None		
$0.2 < W$	-	None				

Note

(1) Definition of average diameter D

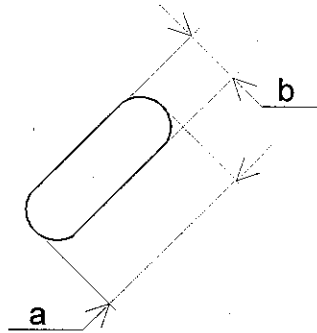

$$D = \frac{a+b}{2}$$

(2) Definition of length L and width W

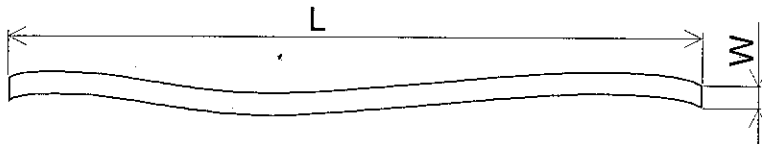

(3) Definition of pinhole

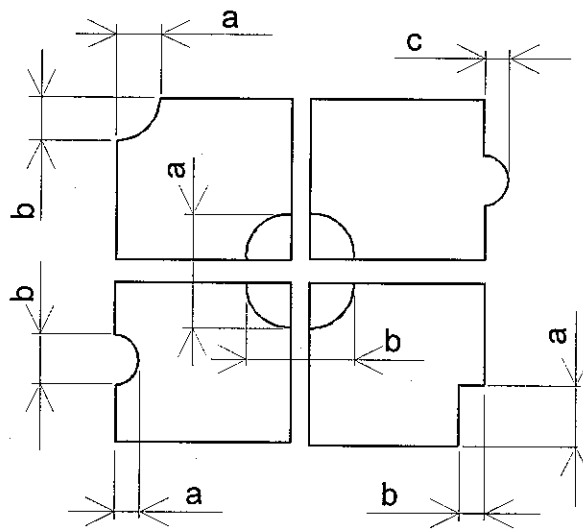

11. PRECAUTION IN DESIGN

11.1 Mounting Method

Since the module is so constructed as to be fixed by utilizing fitting holes in the module as shown below, it is necessary to take consideration the following items on attachment to a frame.

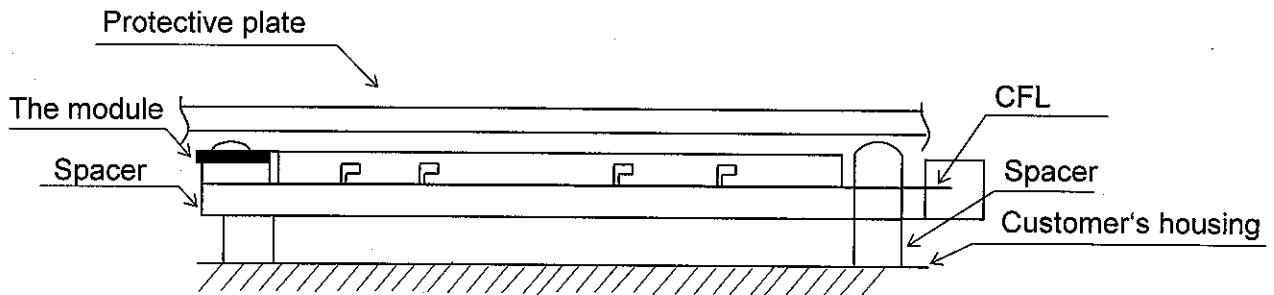

Example of Mounting

Unit : mm

Scale : NTS

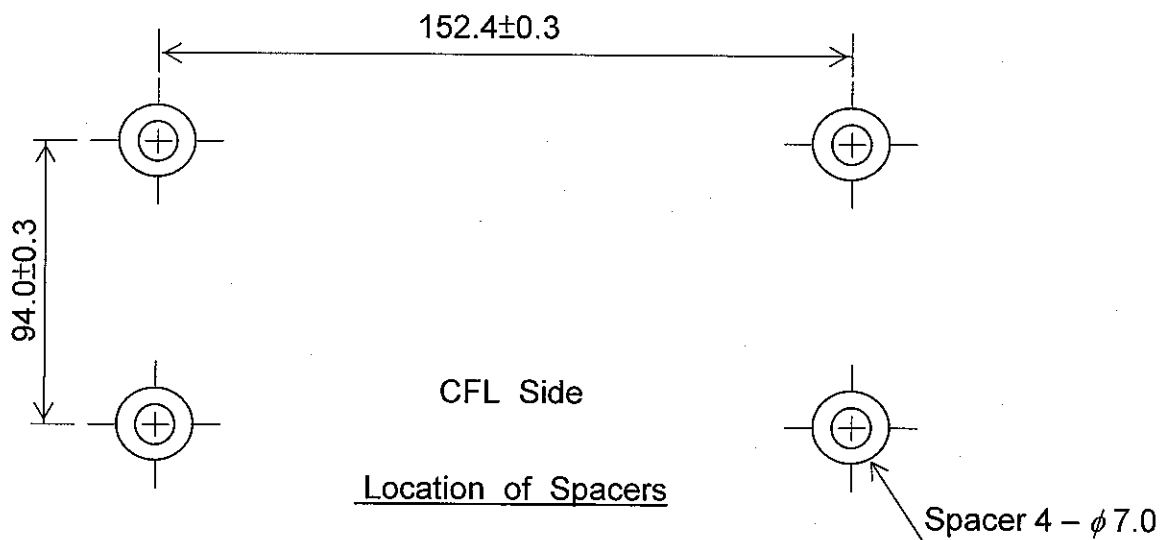

- (1) Use of protective plate, made of an acrylic plate, etc, in order to protect a polarizer and LC cell.
- (2) To prevent the model cover from being pressed, the spacers between the module and the fitting plates should be longer than 0.5mm.
- (3) We recommend you to use protective spacer as figure for protecting LCD module from any kind of shock to your set.

11.2 LC driving voltage (V0) and viewing angle range.

Setting V0 out of the recommended condition will be a cause for a change of viewing angle range.

11.3 CAUTION AGAINST STATIC CHARGE

As this module is provided with C-MOS LSI, the care to take such a precaution as to grounding the operator's body is required when handling it.

11.4 POWER ON SEQUENCE

Input signals should not be applied to LCD module before power supply voltage is applied and reaches to specified voltage ($5\pm 0.25V$).

If above sequence is not kept, C-MOS LSIS of LCD modules may be damaged due to latch up problem.

11.5 PACKAGING

(1) No. leaving products is preferable in the place of high humidity for a long period of time. for their storage in the place where temperature is $35^{\circ}C$ or higher, special care to prevent them from high humidity is required.

A combination of high temperature and high humidity may cause them polarization degradation as well as bubble generation and polarizer peel-off. Please keep the temperature and humidity within the specified range for use and storing.

(2) Since upper polarizers and lower aluminum plates tend to be easily damaged, they should be handled with full care so as not to get them touched, pushed or rubbed by a piece of glass, tweezers and anything else which are harder than a pencil lead 3h.

(3) As the adhesives used for adhering upper/lower polarizers and aluminum plates are made of organic substances which will be deteriorated by a chemical reaction with such chemicals as acetone, toluene ethanol and isopropyl alcohol.

The following solvents are recommended for use:
normal hexane

please contact us when it is necessary for you to use chemicals other than the above.

(4) Lightly wipe to clean the dirty surface with absorbent cotton waste or other soft material like chamois, soaked in the chemicals recommended without scrubbing it hardly.

To prevent the display surface from damage and keep the appearance in good state, it is sufficient, in general, to wipe it with absorbent cotton.

(5) Immediately wipe off saliva or water drop attached on the display area because its long period adherence may cause deformation or faded color on the spot.

(6) Foggy dew deposited on the surface and contact terminals due to coldness will be a cause for polarizer damage, stain and dirt on product.

When necessary to take out the products from some place at low temperature for test, etc.

It is required for them to be warmed up in a container once at the temperature higher than that of room.

- (7) Touching the display area and contact terminals with bare hands and contaminating them are prohibited, because the stain on the display area and poor insulation between terminals are often caused by being touched by bare hands. (There are some cosmetics detrimental to polarizers.)
- (8) In general the quality of glass is fragile so that it tends to be cracked or chipped in handling, specially on its periphery please be careful not give it sharp shock caused by dropping down, ect.

11.6 CAUTION FOR OPERATION

- (1) It is an indispensable condition to drive LCD's within the specified voltage limit since the higher voltage than the limit causes the shorter LCD life. An electrochemical reaction due to direct current causes LCD's undesirable deterioration, so that the use of direct current driver should be avoided.
- (2) Response time will be extremely delayed at lower temperature than the operating temperature range and on the other hand at higher temperature LCD's show dark blue color in them. However those phenomena do not mean inpediment or out of order with LCD's which will come back in the specified operating temperature range.
- (3) If the display area is pushed hard during operation, some font will be abnormally displayed but it resumes normal condition after turning off once.
- (4) A slight dew depositing on terminals is a cause for electrochemical reaction resulting in terminal open circuit.

Usage under the relative condition of 40°C 50%RH less is required.

11.7 STORAGE

In case of storing for a long period of time (for instance, for years) for the purpose of replacement use, the following ways are recommended.

- (1) Storage in a polyethylene bag with the opening sealed so as not to enter fresh air outside in it, and with no desiccant.
- (2) The placing in a dark room where neither exposure to direct sunlight nor light is, keeping temperature in the range from 0°C to 35°C.
- (3) Storing with no touch on polarizer surface by anything else. (It is recommended to store them as they have been contained in the inner container at the time of delivery from us.)

11.8 SAFETY

- (1) It is recommendable to crash damaged or unnecessary LCD's into pieces and wash off liquid crystal by either of solvents such as acetone and ethanol, which should be burned up later.
- (2) When any liquid leaked out of a damaged glass gail comes in contact with your hands, please wash it off well with soap and water.

12. DESIGNATION OF LOT MARK

12.1 Lot Mark

Lot mark is consisted of 4 digits for production lot.

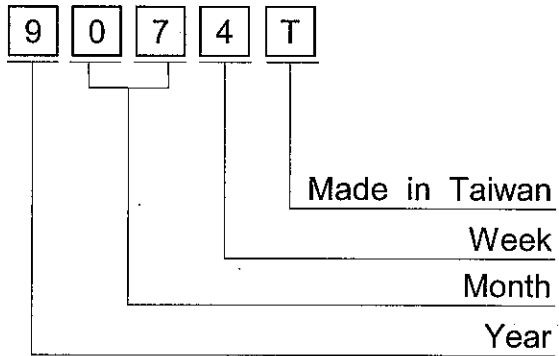

YEAR	FIGURE IN LOT MARK
2009	9
2010	0
2011	1
2012	2

MONTH	FIGURE IN LOT MARK	MONTH	FIGURE IN LOT MARK
Jan.	01	Jul.	07
Feb.	02	Aug.	08
Mar.	03	Sep.	09
Apr.	04	Oct.	10
May	05	Nov.	11
Jun.	06	Dec.	12

WEEK (DAY IN CALENDAR)	FIGURE IN LOT MARK
01~07	1
08~14	2
15~21	3
22~29	4
30~31	5

12.2 REVISION

REV No.	ITEM	LOT No.
A	CCFL tube diameter ($\phi 2.6 \rightarrow \phi 2.4$)	-
B	CFL I/F Connector : Mitsumi M63M83-04 \rightarrow JAE IL-G-4S-S3C2-SA	7102T
C	M-count IC Change Controller IC (T6963C)	-
D	Controller IC (RA6963)	-

12.3 LOCATION OF LOT MARK

on the back side of LCM

9074T

13. PRECAUTION FOR USE

(1) A limit sample should be provided by the both parties on an occasion when the both parties agreed its necessity.

Judgement by a limit sample shall take effect after the limit sample has been established and confirmed by the both parties.

(2) On the following occasions, the handling of the problem should be decided through discussion and agreement between responsible persons of the both parties.

(1) When a question is arisen in the specifications.

(2) When a new problem is arisen which is not specified in this specifications.

(3) When an inspection specifications change or operating condition change in customer is reported to hitachi, and some problem is arisen in this specification due to the change.

(4) When a new problem is arisen at the customer's operating set for sample evaluation in the customer site.

(3) Regarding the treatment for maintenance and repairing, both parties will discuss it in six months later after latest delivery of this product.

The precaution that should be observed when handling LCM have been explained above.

If any points are unclear of if you have any requests, please contact HITACHI.