

THIS DRAWING IS UNPUBLISHED. RELEASED FOR PUBLICATION

© COPYRIGHT BY TYCO ELECTRONICS CORPORATION. ALL RIGHTS RESERVED.

LOC	DIST	REVISIONS			
P	LTR	DESCRIPTION	DATE	DWN	APVD
CM	00	AC	REVISED PER 0G3B-0816-03	07-NOV-03	KW SR
		AC1	REV PER ECO-09-021826	08SEP09	KK AEG

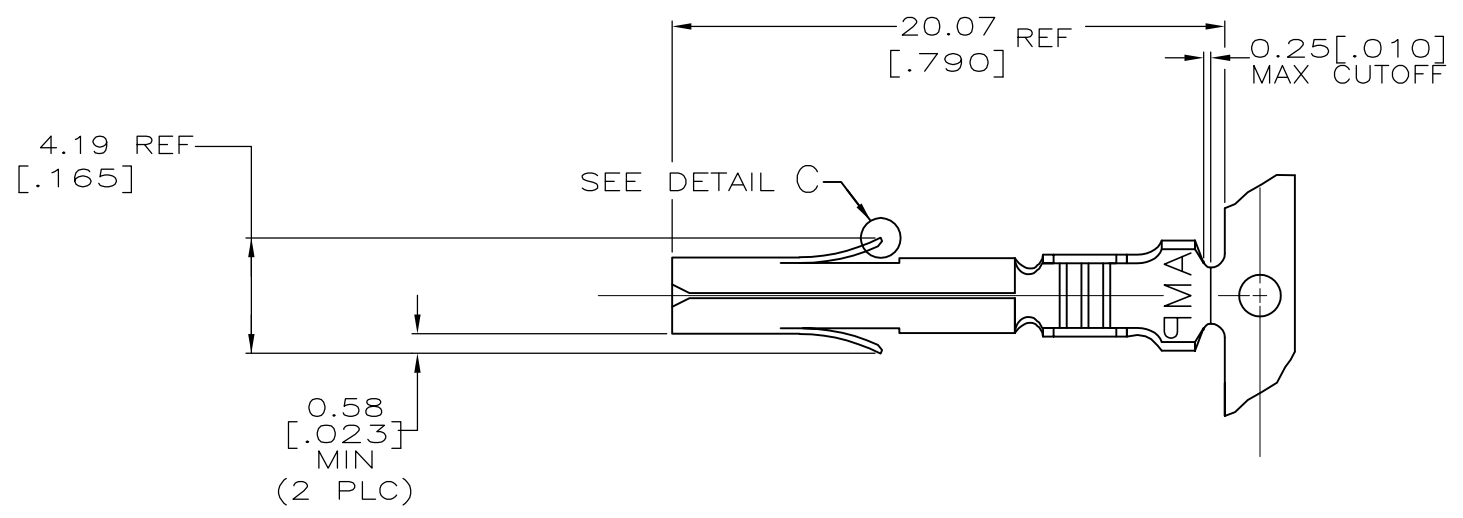

- ① 0.00076[.000030] THK GOLD OVER NICKEL ON INSIDE OF RECEPTACLE AND WIRE BARREL; REMAINDER OF CONTACT IS NICKEL PLATED.
- ② 0.00076[.000030] THK GOLD ON INSIDE OF RECEPTACLE; REMAINDER OF CONTACT IS NICKEL PLATED.
- 3. DIMENSIONS IN BRACKETS ARE IN INCHES.
- ④ PRELIMINARY, NOT FOR PRODUCTION.
- ⑤ OBSOLETE PARTS: OBSOLETE CIS STREAMLINING PER D.RENAUD/D.SINISI

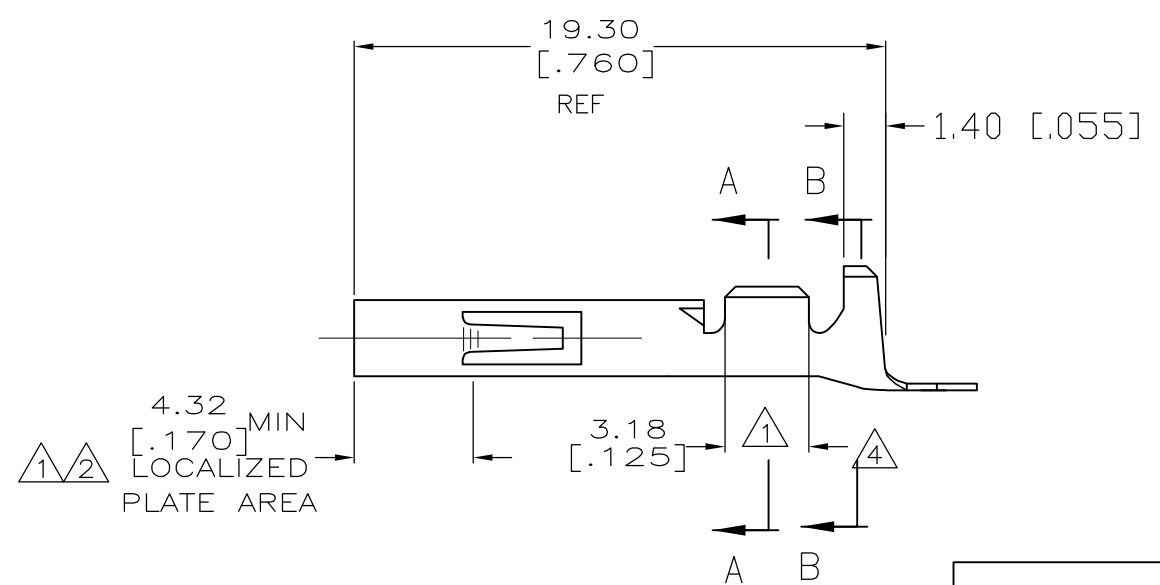
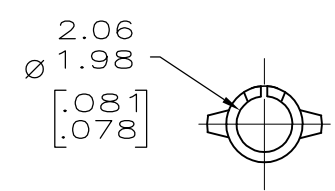
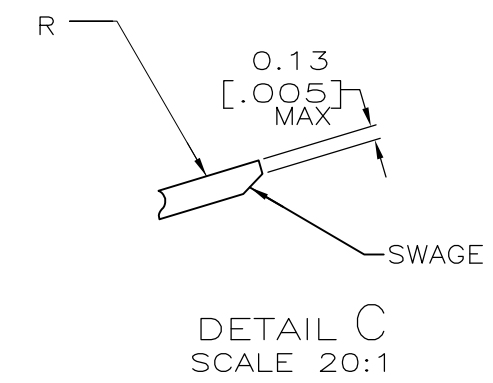

LOOSE PIECE (REF)	APPLICATOR TYPE	FINISH	MATERIAL	PART NUMBER
-	-	TIN	0.30 [.012] BE CU	1-350536-0
-	STANDARD	TIN	0.30 [.012] PH BZ	-350536-9-
350550-7	MINI	GOLD ②	0.30 [.012] BRASS	350536-7
350550-6	MINI	GOLD ②	0.30 [.012] PH BZ	350536-6
350550-3	MINI	TIN	0.30 [.012] PH BZ	350536-3
350550-2	MINI	GOLD ①	0.30 [.012] BRASS	350536-2
350550-1	MINI	TIN	0.30 [.012] BRASS	350536-1

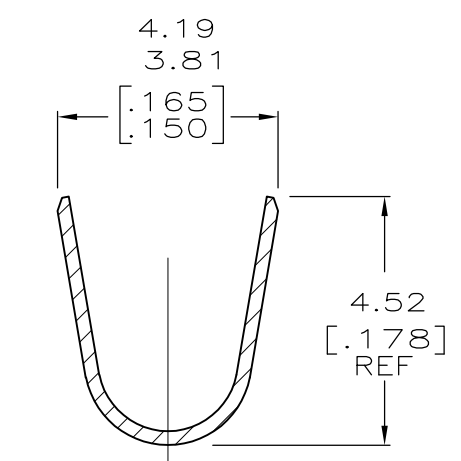
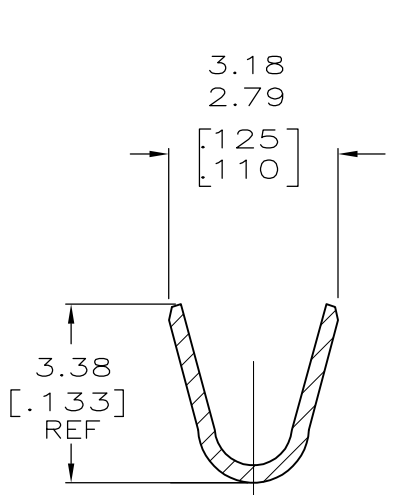

SECTION A-A
SCALE 10:1

SECTION B-B
SCALE 10:1

THIS DRAWING IS A CONTROLLED DOCUMENT.

DWN K. WHITAKER 07NOV2003	Tyco Electronics Tyco Electronics Corporation Harrisburg, PA 17105-3608
CHK S. RIDGILL 07-NOV-03	
APVD S. RIDGILL 07-NOV-03	NAME SOCKET, UNIVERSAL MATE-N-LOK™
PRODUCT SPEC -	SIZE A3
APPLICATION SPEC -	CAGE CODE 00779
WEIGHT -	DRAWING NO C-350536
CUSTOMER DRAWING	RESTRICTED TO -

SCALE 1:5 SHEET 1 OF 1 REV AC1