

ECM Series



- Compact Size
- IT & Medical Approvals
- Convection-cooled
- Class I and II Construction
- DC Input Version Available (DCM Series)
- PoE Isolation Version Available (POE Series)
- 3 Year Warranty

Specification

Input

Input Voltage	• 90-264 VAC (120-370 VDC)
Input Frequency	• 47-63 Hz; 440 Hz*
Input Current	• 40 W: 0.4 A max at 230 VAC 60 W: 0.6 A max at 230 VAC 100 W: 0.9 A max at 230 VAC
Inrush Current	• 40 A max at 230 VAC
Earth Leakage Current	• <125 μ A at 115 VAC/60 Hz <210 μ A at 230 VAC/50 Hz
Power Factor	• EN61000-3-2
Input Protection	• Internal T3.15 A, 250 V fuse in line and neutral

Output

Output Voltage	• See tables
Output Voltage Trim	• \pm 5% on 3.3 V & 5 V versions, \pm 10% on other single output models and V1 of multi-output models. (See note 1 for ECM40/60 models)
Initial Set Accuracy	• \pm 1.0% V1, \pm 5% V2, V3 & V4
Minimum Load	• See tables
Start Up Delay	• 1.5 s max
Start Up Rise Time	• 10 ms max
Hold Up Time	• 16/75 ms min at 115/230 VAC
Line Regulation	• \pm 0.5%
Load Regulation	• \pm 1% single output models; \pm 3% V1, \pm 5% V2 & V3 ECM40/60 multi-output models. \pm 1% V1 & V2, \pm 5% V3 & V4 ECM100
Cross Regulation	• 2% on ECM40/60 only
Over/Undershoot	• None at turn on/off
Transient Response	• 4% max. deviation, recovery to within 1% in 500 μ s for a 25% load change
Ripple & Noise	• 1% pk-pk, 20 MHz bandwidth
Overvoltage Protection	• 115-135% Vnom, recycle input to reset
Overload Protection	• 110-150% on primary power limit, auto recovery
Short Circuit Protection	• Trip and restart (hiccup mode)
Temperature Coefficient	• 0.05%/ $^{\circ}$ C
Peak Load	• 120% for 100 ms ECM40/60 (see note 3)

General

Efficiency	• 80-85% depending on model
Isolation	• 4000 VAC Input to Output 2 x MOPP ECM100 single output models, 1 x MOPP ECM100 multi output and all ECM40/60 models (contact sales for 2 x MOPP), 1500 VAC Input to Ground 1 x MOPP, 500 VAC Output to Ground
Switching Frequency	• 70 kHz typical
Power Density	• 40 W: 4.2 W/In ³ 60 W: 6.3 W/In ³ 100 W: 7.4 W/In ³
MTBF	• 600 kHrs to MIL-HDBK-217F at 25 $^{\circ}$ C, GB

Environmental

Operating Temperature	• 0 $^{\circ}$ C to +70 $^{\circ}$ C. Refer to derating curves for specific operating limitations.
Cooling	• Convection & fan-cooled ratings (see derating curves)
Operating Humidity	• 95% RH, non-condensing
Storage Temperature	• -40 $^{\circ}$ C to +85 $^{\circ}$ C
Operating Altitude	• 3000 m
Shock	• 30 g pk, half sine, 6 axes
Vibration	• 2 g rms, 5 Hz to 500 Hz, 3 axes

EMC & Safety

Emissions	• EN60601-1-2, EN61204-3, FCC 20780, EN55022 & EN55011, level B conducted EN55022 Level A radiated
Harmonic Currents	• EN61000-3-2, class A
Voltage Flicker	• EN61000-3-3
ESD Immunity	• EN61000-4-2, level 3 Perf Criteria A
Radiated Immunity	• EN61000-4-3, 10 V/m Perf Criteria A
EFT/Burst	• EN61000-4-4, level 3 Perf Criteria A
Surge	• EN61000-4-5, level 3 Perf Criteria A, SEMI F47
Conducted Immunity	• EN61000-4-6, 10 V Perf Criteria A
Dips & Interruptions	• EN61000-4-11, 30% 10 ms, 60% 100 ms, 100% 5000 ms, Perf Criteria A, B, B EN60601-1, 30% 500 ms, 60% 100 ms, 100% 10 ms, 100% 5000 ms, Perf Criteria A, A (with 50% load), A, B
Safety Approvals	• EN60601-1, ANSI/AAMI ES60601-1, CSA22.2 No.60601-1 per cUL, Including Risk Management, EN60950, UL6095

* Safety approvals cover frequency range 47-63 Hz

Models and Ratings

Output Power	Output 1		Output 2		Output 3		Model Number ⁽²⁾
	Voltage	Current Min/Max ⁽³⁾	Voltage	Current Min/Max	Voltage	Current Min/Max	
40 W	5.0 V	0.0 A/8.0 A					ECM40US05†^
	7.0 V	0.0 A/5.7 A					ECM40US07†
	9.0 V	0.0 A/4.4 A					ECM40US09†^
	12.0 V	0.0 A/3.5 A					ECM40US12†^
	15.0 V	0.0 A/2.7 A					ECM40US15†^
	18.0 V	0.0 A/2.2 A					ECM40US18†
	24.0 V	0.0 A/1.7 A					ECM40US24†^
	33.0 V	0.0 A/1.2 A					ECM40US33†
	48.0 V	0.0 A/0.9 A					ECM40US48†^
	+5.0 V	0.5 A/6.0 A	+12.0 V	0.1 A/2.0 A			ECM40UD21†
	+5.0 V	0.5 A/6.0 A	+15.0 V	0.1 A/1.5 A			ECM40UD22
	+5.0 V	0.5 A/6.0 A	+12.0 V	0.1 A/2.0 A	-12.0 V	0.0 A/0.5 A	ECM40UT31†^
	+5.0 V	0.5 A/6.0 A	+24.0 V	0.1 A/1.0 A	-12.0 V	0.0 A/0.5 A	ECM40UT32†
	+5.0 V	0.5 A/6.0 A	+15.0 V	0.1 A/1.5 A	-15.0 V	0.0 A/0.5 A	ECM40UT33†^
	+3.3 V	0.5 A/6.0 A	+5.0 V	0.1 A/1.5 A	+12.0 V	0.0 A/0.5 A	ECM40UT34†^
	+5.0 V	0.5 A/6.0 A	+3.3 V	0.1 A/1.5 A	+12.0 V	0.0 A/0.5 A	ECM40UT35†

Notes

- V2 will track a change in V1 by the same percentage change in voltage as V1 is trimmed.
- To receive unit with cover fitted, add suffix '-C' to model number. For Class I operation only.
- A 120% peak load can be taken for up to 100 ms with a 25% duty cycle. Average load not to exceed 40 W.

† Available from Farnell & element14. See pages 284-290.

^ Available from Newark. See pages 291-296.

Mechanical Details

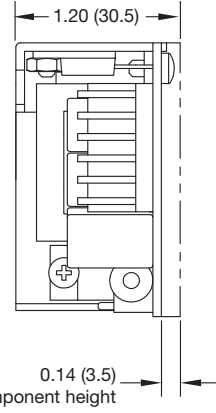
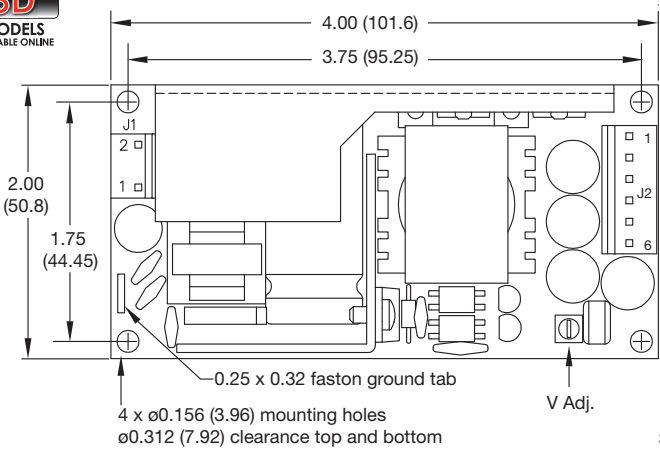

Input Connector J1	
Pin 1	Line
Pin 2	Neutral

J1 mates with Molex housing 43061-0003 & Molex series 5194 crimp terminals. Ground tab (0.25 faston) standard.

Output Connector J2		
Pin	Single	Multi
1	V1	+V1
2	V1	+V1
3	RTN	RTN
4	RTN	RTN
5	NC	V3
6	NC	+V2

J2 mates with Molex housing 43061-0006 & Molex series 5194 crimp terminals.

Notes

- All dimensions in inches (mm). Tolerance .xx = ±0.02 (0.50); .xxx = ±0.01 (0.25)
- Weight: approx. 0.33 lbs (150 g)
- Cable harnesses with 300 mm wire available. For single output models, order part number ECM40/60S LOOM†. For multi-output models, order part number ECM40/60DT LOOM†^.
- Mating connector kit available. Order part number ECM40/60 CONKIT†.
- Covers available. Order part number ECM40/60 COVER†^.
- Cover dimensions are 4.49 x 2.52 x 1.52 (114 x 64 x 38.5)
- 3D drawing files available from www.xppower.com/cad.php.

Derating Curves

All ECM40 models convection-cooled

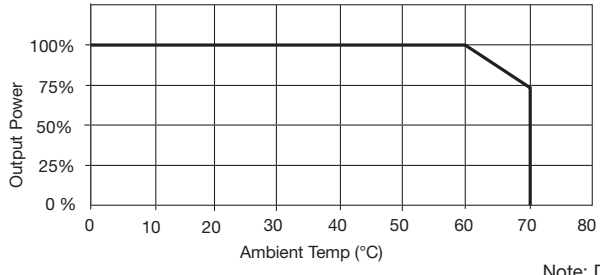

All ECM40 models with 5 CFM

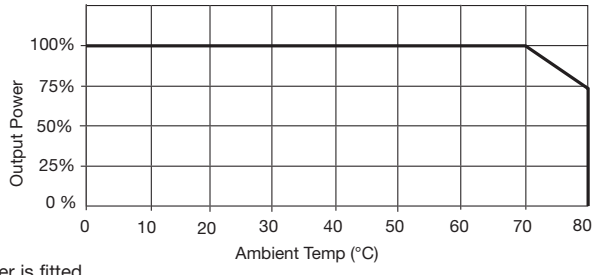

Note: Derate by 10% if cover is fitted

Consult longform datasheet for installation information regarding optimum thermal ratings in convection-cooled applications.



Models and Ratings

Output Power	Output 1		Output 2		Output 3		Model Number ⁽²⁾
	Voltage	Current Min/Max ⁽³⁾	Voltage	Current Min/Max	Voltage	Current Min/Max	
60 W	5.0 V	0.0 A/12.00 A					ECM60US05 ^{†^}
	7.0 V	0.0 A/8.60 A					ECM60US07
	9.0 V	0.0 A/6.70 A					ECM60US09 [^]
	12.0 V	0.0 A/5.00 A					ECM60US12 ^{†^}
	15.0 V	0.0 A/4.00 A					ECM60US15 ^{†^}
	18.0 V	0.0 A/3.30 A					ECM60US18 [†]
	20.0 V	0.0 A/3.00 A					ECM60US20
	24.0 V	0.0 A/2.50 A					ECM60US24 ^{†^}
	28.0 V	0.0 A/2.14 A					ECM60US28
	33.0 V	0.0 A/1.80 A					ECM60US33
	48.0 V	0.0 A/1.25 A					ECM60US48 ^{†^}
	+5.0 V	0.5 A/8.00 A	+12.0 V	0.1 A/3.0 A			ECM60UD21 [^]
	+5.0 V	0.5 A/8.00 A	+15.0 V	0.1 A/2.5 A			ECM60UD22
	+5.0 V	0.5 A/8.00 A	+12.0 V	0.1 A/3.0 A	-12.0 V	0.0 A/0.5 A	ECM60UT31 ^{†^}
	+5.0 V	0.5 A/8.00 A	+24.0 V	0.1 A/1.5 A	-12.0 V	0.0 A/0.5 A	ECM60UT32 [†]
	+5.0 V	0.5 A/8.00 A	+15.0 V	0.1 A/2.5 A	-15.0 V	0.0 A/0.5 A	ECM60UT33 ^{†^}
	+3.3 V	0.5 A/8.00 A	+5.0 V	0.1 A/1.5 A	+12.0 V	0.0 A/0.5 A	ECM60UT34 ^{†^}
	+5.0 V	0.5 A/8.00 A	+3.3 V	0.1 A/1.5 A	+12.0 V	0.0 A/0.5 A	ECM60UT35 [†]

Notes

- V2 will track a change in V1 by the same percentage change in voltage as V1 is trimmed.
- To receive unit with cover fitted, add suffix '-C' to model number. For Class I operation only.
- A 120% peak load can be taken for up to 100 ms with a 25% duty cycle. Average load not to exceed 60 W.

[†] Available from Farnell & element14. See pages 284-290.

[^] Available from Newark. See pages 291-296.

Mechanical Details

3D MODELS AVAILABLE ONLINE

4.00 (101.6)
3.75 (95.25)
2.00 (50.8)
1.75 (44.45)
0.25 x 0.32 faston ground tab
4 x ø0.156 (3.96) mounting holes
ø0.312 (7.92) clearance top and bottom
V Adj.
1.20 (30.5)
0.14 (3.5) SMD component height

Input Connector J1	
Pin 1	Line
Pin 2	Neutral

J1 mates with Molex housing 43061-0003 & Molex series 5194 crimp terminals. Ground (0.25 faston) tab standard.

Output Connector J2		
Pin	Single	Multi
1	V1	+V1
2	V1	+V1
3	RTN	RTN
4	RTN	RTN
5	NC	V3
6	NC	+V2

J2 mates with Molex housing 43061-0006 & Molex series 5194 crimp terminals.

Notes

- All dimensions in inches (mm). Tolerance .xx = ±0.02 (0.50); .xxx = ±0.01 (0.25)
- Weight: 0.33 lbs (150 g) approx.
- Cable harnesses with 300 mm wire available.
For single output models, order part number ECM40/60S LOOM[†].
For multi-output models, order part number ECM40/60DT LOOM[†].
- Mating connector kit available. Order part number ECM40/60 CONKIT[†].
- Covers available. Order part number ECM40/60 COVER^{†^}. Cover dimensions are 4.49 x 2.52 x 1.52 (114 x 64 x 38.5).
- Selected single output models available in a 3" x 5" footprint for OEM quantities. Contact sales for details.
- 3D drawing files available from www.xppower.com/cad.php.

Derating Curves

All ECM60 models convection-cooled

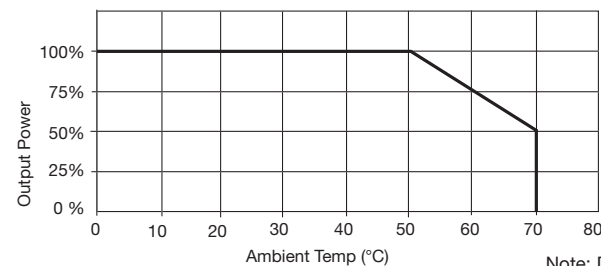

Note: Derate by 10% if cover is fitted

All ECM60 models with 5 CFM

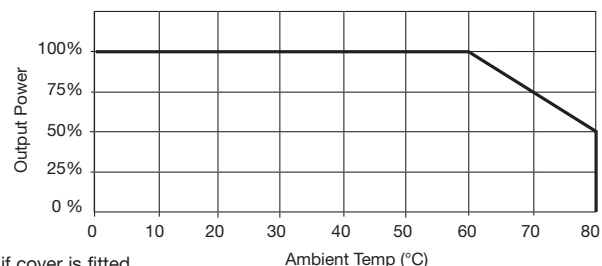

Consult longform datasheet for installation information regarding optimum thermal ratings in convection-cooled applications.

Models and Ratings

Single Output Models

Output Voltage	Output Current			Model Number ⁽¹⁾
	Minimum	Maximum	with 5 CFM Cooling	
3.3 V	0.0 A	15.0 A	20.0 A	ECM100US03 ^{†^}
5.0 V	0.0 A	15.0 A	20.0 A	ECM100US05 ^{†^}
7.0 V	0.0 A	11.4 A	14.3 A	ECM100US07
9.0 V	0.0 A	8.8 A	11.1 A	ECM100US09 ^{†^}
12.0 V	0.0 A	7.5 A	8.3 A	ECM100US12 ^{†^}
15.0 V	0.0 A	6.0 A	6.6 A	ECM100US15 ^{†^}
18.0 V	0.0 A	5.0 A	5.5 A	ECM100US18
24.0 V	0.0 A	4.1 A	4.1 A	ECM100US24 ^{†^}
28.0 V	0.0 A	3.6 A	3.6 A	ECM100US28
33.0 V	0.0 A	3.0 A	3.0 A	ECM100US33
48.0 V	0.0 A	2.1 A	2.1 A	ECM100US48 ^{†^}

Multi Output Models

Output Power		Output 1		Output 2		Output 3		Output 4		Model Number ⁽¹⁾
Convection Cooled	Forced Air 5 CFM	Voltage	Current Min/Max	Voltage	Current Min/Max	Voltage	Current Min/Max	Voltage	Current Min/Max	
80 W	100 W	+5.0 V	0.0 A/12.0 A	+12.0 V	0.0 A/3.0 A					ECM100UD21
80 W	100 W	+5.0 V	0.0 A/12.0 A	+15.0 V	0.0 A/3.0 A					ECM100UD22
75 W	100 W	+5.0 V	0.5 A/10.0 A	+12.0 V	0.0 A/3.0 A	-12.0 V	0.0 A/0.8 A			ECM100UT31 ^{†^}
80 W	100 W	+5.0 V	0.5 A/10.0 A	+24.0 V	0.0 A/2.0 A	-12.0 V	0.0 A/0.8 A			ECM100UT32
80 W	100 W	+5.0 V	0.5 A/10.0 A	+15.0 V	0.0 A/3.0 A	-15.0 V	0.0 A/0.8 A			ECM100UT33 ^{†^}
65 W	100 W	+3.3 V	0.5 A/10.0 A	+5.0 V	0.0 A/5.0 A	+12.0 V	0.0 A/0.8 A			ECM100UT34 [^]
70 W	100 W	+5.0 V	0.5 A/10.0 A	+3.3 V	0.0 A/5.0 A	+12.0 V	0.0 A/0.8 A			ECM100UT35
80 W	100 W	+5.0 V	0.5 A/10.0 A	+12.0 V	0.0 A/3.0 A	-5.0 V	0.0 A/0.8 A			ECM100UT36
70 W	100 W	+5.0 V	0.5 A/10.0 A	+15.0 V	0.0 A/3.0 A	-5.0 V	0.0 A/0.8 A			ECM100UT37
65 W	100 W	+5.0 V	0.5 A/10.0 A	+3.3 V	0.1 A/5.0 A	+12.0 V	0.0 A/0.8 A	-12.0 V	0.0 A/0.5 A	ECM100UQ41 ^{†^}
60 W	100 W	+3.3 V	0.5 A/10.0 A	+5.0 V	0.1 A/5.0 A	+12.0 V	0.0 A/0.8 A	-12.0 V	0.0 A/0.5 A	ECM100UQ42 ^{†^}
80 W	100 W	+5.0 V	0.5 A/10.0 A	+24.0 V	0.1 A/2.0 A	+12.0 V	0.0 A/0.8 A	-12.0 V	0.0 A/0.5 A	ECM100UQ43 ^{†^}
80 W	100 W	+5.0 V	0.5 A/10.0 A	+24.0 V	0.1 A/2.0 A	+15.0 V	0.0 A/0.8 A	-15.0 V	0.0 A/0.5 A	ECM100UQ44 ^{†^}
80 W	100 W	+5.0 V	0.5 A/10.0 A	+12.0 V	0.1 A/3.0 A	-12.0 V	0.0 A/0.8 A	-5.0 V	0.0 A/0.5 A	ECM100UQ45 [^]
80 W	100 W	+5.0 V	0.5 A/10.0 A	+15.0 V	0.1 A/3.0 A	-15.0 V	0.0 A/0.8 A	-5.0 V	0.0 A/0.5 A	ECM100UQ46

Notes

1. To receive unit with cover fitted, add suffix '-C' to model number.

[†] Available from Farnell & element14. See pages 284-290.

2. Output 3 available with opposite polarity for OEM quantities.

[^] Available from Newark. See pages 291-296.

Mechanical Details

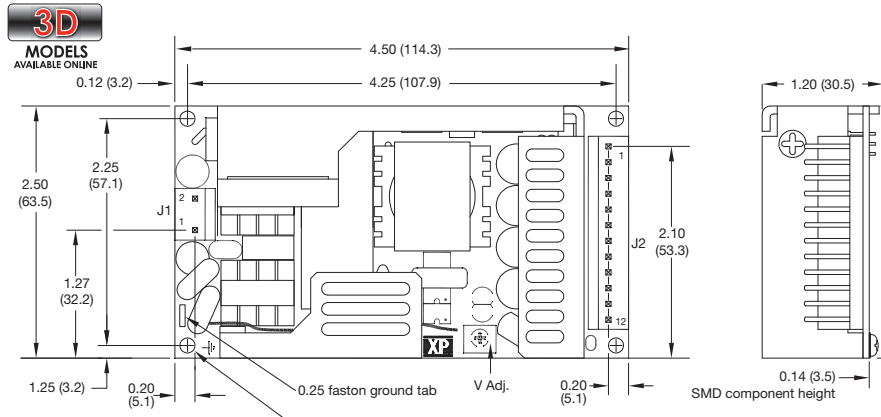

Cover dimensions are 4.98 x 3.01 x 1.54 (126.5 x 76.4 x 39.0)

Input Connector J1	
Pin 1	Line
Pin 2	Neutral

J1 mates with Molex housing 43061-0003 and Molex series 5194 crimp terminals. Ground (0.25 faston) tab standard.

Output Connector J2		
Pin	Single	Multi
1	V1	+V1
2	V1	+V1
3	V1	+V1
4	V1	+V1
5	V1 RTN	RTN
6	V1 RTN	RTN
7	V1 RTN	RTN
8	V1 RTN	RTN
9	NOT USED	+V2
10	NOT USED	+V2
11	NOT USED	±V3
12	NOT USED	-V4

J2 mates with Molex housing 43061-0012 and Molex series 5194 crimp terminals.

Notes

- All dimensions in inches (mm). Tolerance .xx = ±0.02 (0.50); .xxx = ±0.01 (0.25)
- Weight: 0.4 lbs (180 g) approx.
- Cable harness with 300 mm wire available. For single output models, order part number ECM100S LOOM[†]. For multi-outputs, p/n ECM100DT LOOM[†].

- Mating connector kit available for single output models. Order part number ECM100S CONKIT^{†^}.
- Covers available. Order part number ECM100 COVER^{†^}.
- Available in a 3" x 5" footprint for OEM quantities. Contact sales for details.
- 3D drawing files available from www.xppower.com/cad.php.

Derating Curves

All ECM100 single output models convection-cooled

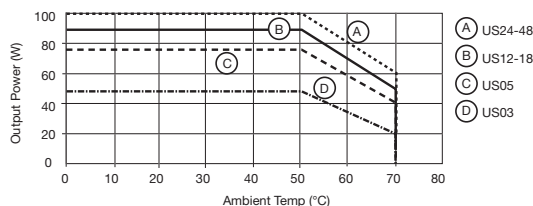

- Note:
- Derate by 10% if cover is fitted.
 - For multi output convection-cooled operation above +50 °C derate linearly to 50% at +70 °C.

All ECM100 models with 5 CFM

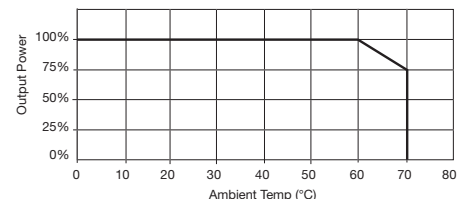

Consult longform datasheet for installation information regarding optimum thermal ratings in convection-cooled applications.



Input Voltage Range ⁽¹⁾	Input Current	UVLO	Output Voltage	Output Current			Model Number
				Min ⁽⁶⁾	Max Convection -cooling	Max - 5CFM forced -cooling	
36-76 VDC (48 VDC Nominal)	1.5 A (2.5 A max)	32 - 35 VDC	12 V	0.25 A	5.00 A	5.00 A	DCM6048S12
	2.2 A (3.5 A max)		12 V	0.40 A	7.50 A	8.30 A	DCM10048S12

Notes

1. Can be configured as -48 VDC input.
2. Input reverse voltage protection is continuous with automatic recovery.
3. Input transients compliant with ETSI EN300 132:2003.
4. For a fitted cover version, add suffix '-C' to model number (power derates by 20% with cover fitted)
5. For full product details contact sales, or visit www.xppower.com
6. 5% minimum load required to meet all specification parameters

Mechanical Details

DCM60

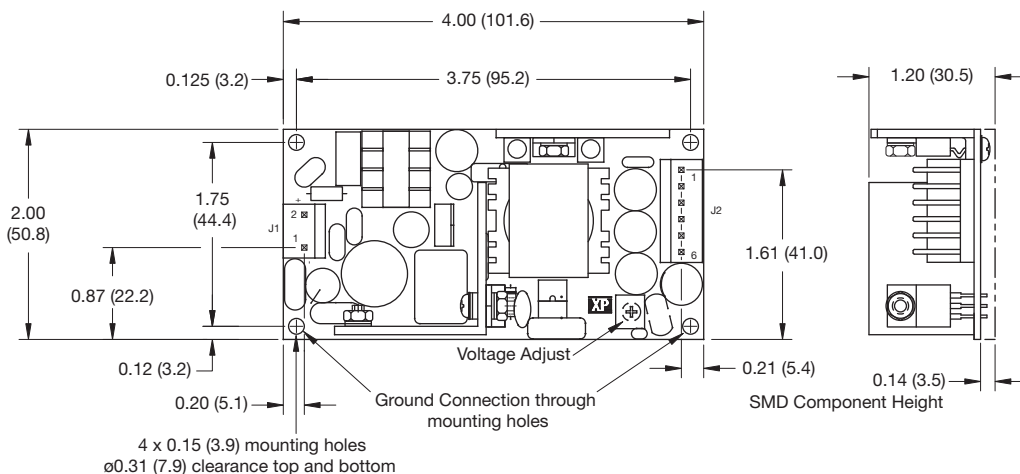

Input Connector J1	
Pin 1	-Vin
Pin 2	+Vin

J1 mates with Molex housing 43061-0003 & Molex series 5194 crimp terminals

Output Connector J2	
Pin	Single
1	12V
2	12V
3	RTN
4	RTN
5	NC
6	NC

J2 mates with Molex housing 43061-0006 & Molex series 5194 crimp terminals

DCM100

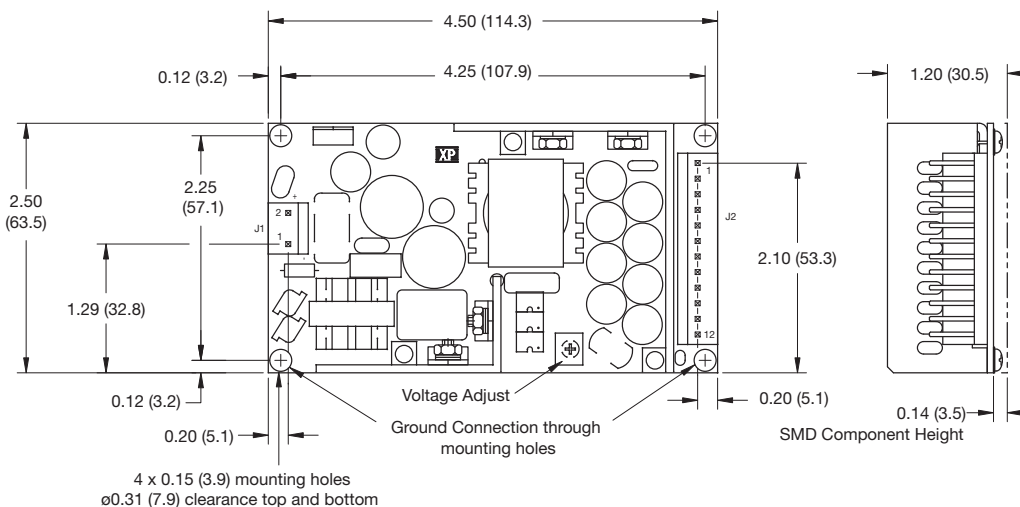

Input Connector J1	
Pin 1	-Vin
Pin 2	+Vin

J1 mates with Molex housing 43061-0003 & Molex series 5194 crimp terminals

Output Connector J2	
Pin	Single
1	12V
2	12V
3	12V
4	12V
5	RTN
6	RTN
7	RTN
8	RTN
9	NC
10	NC
11	NC
12	NC

J2 mates with Molex housing 43061-0012 & Molex series 5194 crimp terminals

Notes

1. All dimensions in inches (mm). Tolerance .xx = ±0.02 (0.50); .xxx = ±0.01 (0.25)
2. Weight: DCM60: 0.3 lbs (136 g) approx. DCM100: 0.4 lbs (181 g) approx.
3. Cover kits available separately, order part number no. ECM40/60 COVER (4.49 x 2.52 x 1.52 (114 x 64 x 38.5)) for DCM60 or part no. ECM100 COVER (4.96 x 3.05 x 1.52 (126 x 77.5 x 38.5)) for DCM100. Output power derates by 20% with cover fitted.

Input Voltage Range	Input Frequency	Input Current		Earth ⁽¹⁾ Leakage Current	Output Power	Output Voltage	Output Current	Model Number
		115 VAC	230 VAC					
90-264 VAC (120-370 VDC)	47-63 Hz	1.8 A max	1.1 A max	<1 mA	100 W	+56 V	1.8 A	POE100US56

Notes

1. Earth leakage current rated at 264 VAC/60 Hz.
2. Input is protected with internal T3.15 A, 250 V, fuse in line
3. Output to Ground Isolation 1500 VAC POE version.
4. For full product details contact sales, or visit www.xppower.com

Mechanical Details

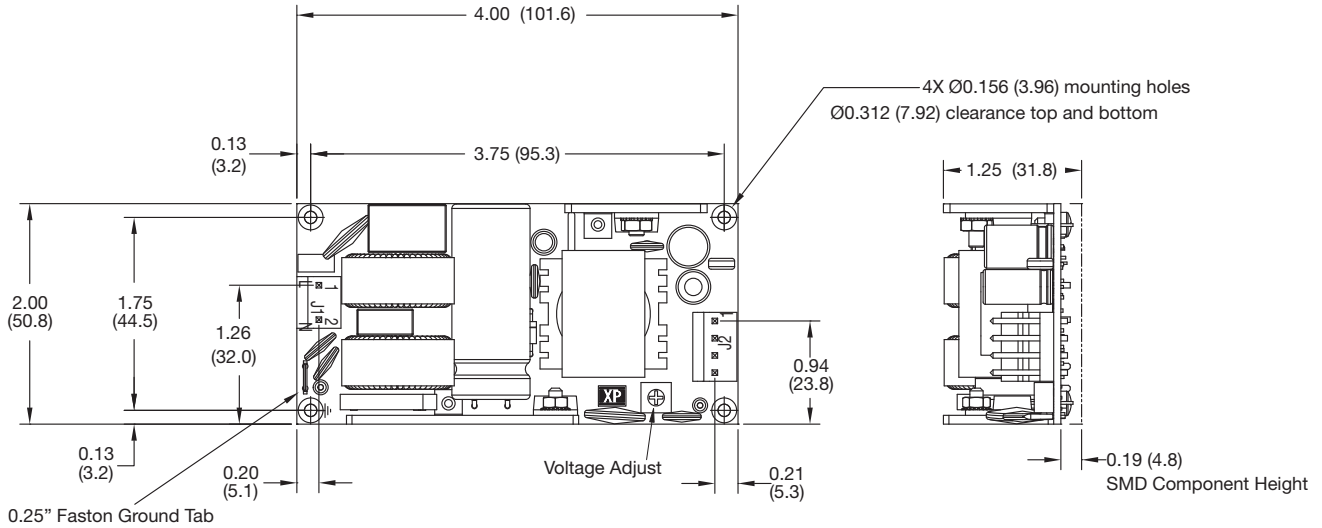

Input Connector J1	
Pin 1	Line
Pin 2	Neutral
0.25" Faston	Earth

J1 mates with Molex housing 09-50-1031 & Molex series 5194 crimp terminals

Output Connector J2	
Pin 1	56V
Pin 2	56V
Pin 3	RTN
Pin 4	RTN

J2 mates with Molex housing 09-50-1041 & Molex series 5194 crimp terminals

Notes

1. All dimensions in inches (mm). Tolerance .xx = ±0.02 (0.50); .xxx = ±0.01 (0.25)
2. Weight 0.35 lb (158 g) approx.

Derating Curves

Convection-cooled

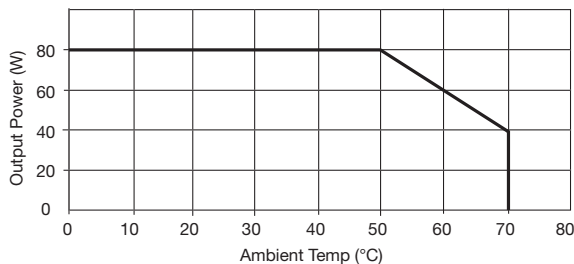

Fan-cooled with 10 CFM

