

ADD PART NUMBER EC NO: SH2010-0232 DRWN: XJ SONG CHKD: XJ SONG APPR: RZHANG	QUALITY SYMBOLS ▽ = 0 ◻ = 0	GENERAL TOLERANCES (UNLESS SPECIFIED)		DIMENSION STYLE MM ONLY	SCALE 5:1	DESIGN UNITS METRIC	THIRD ANGLE PROJECTION		
		4 PLACES ± --- ± ---	3 PLACES ± --- ± ---	2 PLACES ± 0.15 ± ---	1 PLACE ± 0.25 ± ---	DRAWN BY JENNY	DATE 2005/07/22	TITLE HIGH SPEED CONNECTOR 1.27MM PITCH VERTICAL SMT SOLDER TAIL	
		ANGULAR ± 1 °				CHECKED BY GRMA	DATE 2005/07/22	MOLEX INCORPORATED	
		DRAFT WHERE APPLICABLE MUST REMAIN WITHIN DIMENSIONS				APPROVED BY YAP	DATE 2005/07/22	MATERIAL NO. SEE SHEET 2	DOCUMENT NO. SD-47306-001
REV	DESCRIPTION	THIS DRAWING CONTAINS INFORMATION THAT IS PROPRIETARY TO MOLEX INCORPORATED AND SHOULD NOT BE USED WITHOUT WRITTEN PERMISSION		SIZE A3	SHEET NO. 1 OF 2				

10 9 8 7 6 5 4 3 2 1

NOTES:

1. MATERIAL:

HOUSING: HIGH TEMPERATURE THERMAL PLASTIC, GLASS FILLED,
UL94V-0, COLOR: BLACK

TERMINAL: BRASS

POST: BRASS

2. TERMINAL PLATING:

CONTACT AREA: (a) GOLD FLASH

(b) GOLD, THICKNESS=0.76 MICRON MINIMUM

(c) GOLD, THICKNESS=0.38 MICRON MINIMUM

SOLDER TAIL: TIN, THICKNESS=1.27 MICRON MINIMUM

UNDER PLATE: NICKEL, THICKNESS=1.27 MICRON MINIMUM

3. POST PLATING: UNDER PLATE: NICKEL, THICKNESS=1.25 MICRON MINIMUM

TIN, THICKNESS=1.9 MICRON MINIMUM OVER ALL

4. PACKAGING: TAPE REEL

5. PRODUCT SPECIFICATION REFER TO PS-67491-001

6. RECOMMENDED SOLDERING PROCESS: IR PROCESS

7. THE MYLAR STICKED ON THE HOUSING IS JUST USED FOR PICK-UP PLACE,
PLEASE REMOVE IT AFTER REFLOW

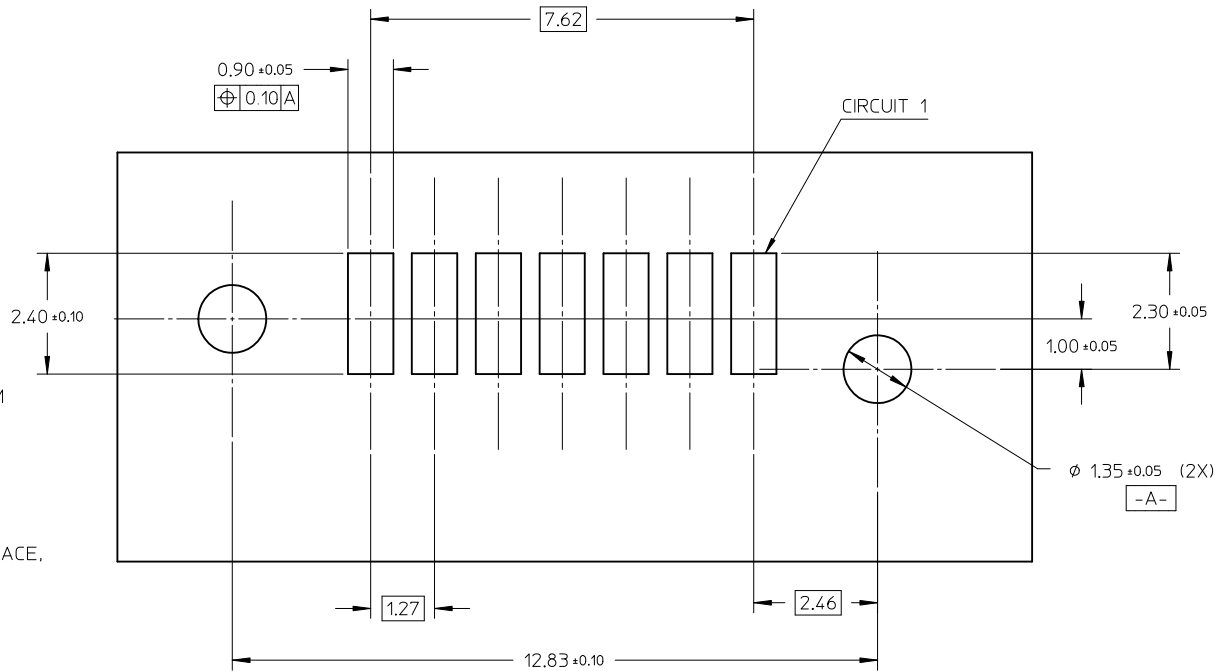

473062105	SEE NOTE2(c)	2.65	WITHOUT	PK-47306-002
473062102	SEE NOTE2(b)			
473062101	SEE NOTE2(a)			
473065025	SEE NOTE2(c)	3.45	WITH	PK-47306-001
473065022	SEE NOTE2(b)			
473065021	SEE NOTE2(a)			
473065015	SEE NOTE2(c)			
473065012	SEE NOTE2(b)			
473065011	SEE NOTE2(a)	3.05	WITH	PK-47306-001
473065005	SEE NOTE2(c)			
473065002	SEE NOTE2(b)	2.65	WITH	PK-47306-001
473065001	SEE NOTE2(a)			
473062025	SEE NOTE2(c)	3.45	WITHOUT	PK-47306-001
473062022	SEE NOTE2(b)			
473062021	SEE NOTE2(a)			
473062015	SEE NOTE2(c)			
473062012	SEE NOTE2(b)			
473062011	SEE NOTE2(a)	3.05	WITHOUT	PK-47306-001
473062005	SEE NOTE2(c)			
473062002	SEE NOTE2(b)			
473062001	SEE NOTE2(a)	2.65	WITHOUT	PK-47306-001
MATERIAL NO	PLATING TYPE	DIM A	MYLAR	PACKING

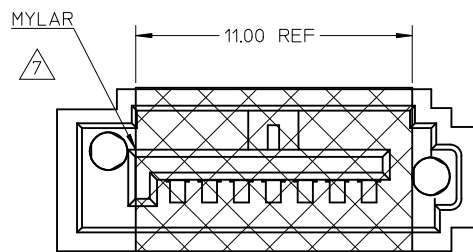

WITH MYLAR TYPE

RECOMMENDED P.C.B LAYOUT
CONNECTOR SIDE

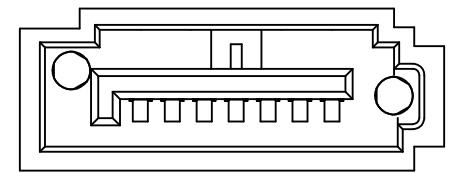

WITHOUT MYLAR TYPE

SEE SHEET1 EC NO: SH2010-0232 DRW: XJ.SONG 2010/01/07 CHKD: XJ.SONG 2010/01/11 APPR: RZHANG 2010/01/14	QUALITY SYMBOLS ▽=0 ∇=0	GENERAL TOLERANCES (UNLESS SPECIFIED)		DIMENSION STYLE MM ONLY		SCALE 5:1	DESIGN UNITS METRIC	THIRD ANGLE PROJECTION	
			mm	INCH	DRAWN BY JENNY	DATE 2005/07/22	TITLE HIGH SPEED CONNECTOR 1.27MM PITCH VERTICAL SMT SOLDER TAIL		
		4 PLACES	± ---	± ---	CHECKED BY GRMA	DATE 2005/07/22	MOLEX INCORPORATED		
		3 PLACES	± ---	± ---	APPROVED BY YAP	DATE 2005/07/22	MATERIAL NO. SD-47306-001	DOCUMENT NO. SD-47306-001	SHEET NO. 2 OF 2
			2 PLACES	± 0.15	± ---	THIS DRAWING CONTAINS INFORMATION THAT IS PROPRIETARY TO MOLEX INCORPORATED AND SHOULD NOT BE USED WITHOUT WRITTEN PERMISSION			
			1 PLACE	± 0.25	± ---				
			ANGULAR ± 1 °						
			DRAFT WHERE APPLICABLE MUST REMAIN WITHIN DIMENSIONS						

9 8 7 6 5 4 3 2 1