

PC BOARD CONNECTORS

740 SERIES

■ FEATURES

- Various types of headers are available: one side shrouded, both sides shrouded, with simplified latch, and box type.
- The connector having a simplified latch prevents the connector from working loose because of vibration.
- The mini header has a clip to prevent incorrect insertion.
- A 740 series connector with a power terminal for SCSI/IDE interface unit connections is also available.

■ SPECIFICATIONS

1. Standard type

Item	Specification
Operating temperature range	-55°C to +105°C
Current rating	DC 1 A
Voltage rating	AC 250 V
Contact resistance	15 mΩ max. (DC 6 V, 0.1 A)
Insulation resistance	1000 MΩ min. (DC 500 V)
Dielectric strength	AC 500 V for 1 minute
Insertion force	3.5 kg max. (10 pins), 10.5 kg max. (30 pins)
Withdrawal force	0.25 kg min. (10 pins), 1.0 kg min. (30 pins)
Applicable wire	Flat cable: 1.27 mm (0.050 in.) pitch AWG #28 (stranded) or AWG #30 (solid)
Applicable PC board (standard)	1.6 mm

2. Power connector integrated type

Item	Specification
Operating temperature range	-55°C to +105°C
Current rating	DC 1 A (signal pin) DC 5 A (power pin)
Voltage rating	AC 250 V
Contact resistance	15 mΩ max. (signal pin, DC 6 V, 0.1 A) 10 mΩ max. (power pin, DC 6 V, 0.3 A)
Insulation resistance	1000 MΩ min. (DC 500 V)
Dielectric strength	AC 500 V for 1 minute (signal pin) AC 1000 V for 1 minute (power pin)
Insertion force	50-contact signal pin: 17.5 kg max. 40-contact signal pin: 14.0 kg max. Power pin (reference value): 8.8 kg max.
Withdrawal force	50-contact signal pin: 2.0 kg max. 40-contact signal pin: 1.5 kg max. Power pin (reference value): 0.8 kg max.
Applicable PC board (standard)	1.6 mm (0.062 in.) (through hole type)

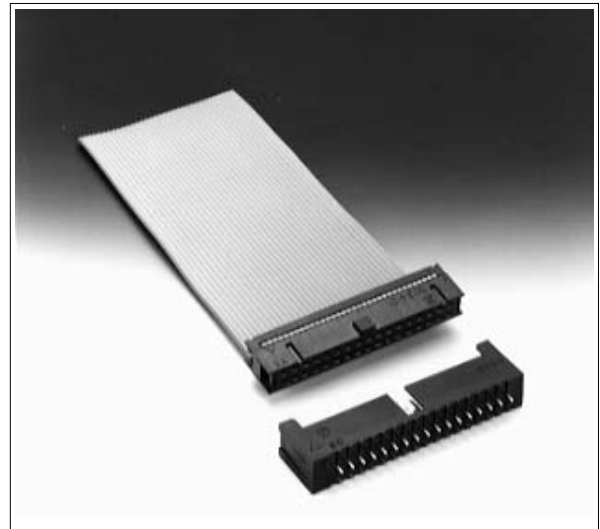

■ MATERIALS

1. Standard type

Item	Materials	
Insulating material	Polyester (UL94V-0)	
Conductor	Copper alloy	
Plating	Contact	Gold
	Terminal	Palladium

2. Power connector integrated type

Item	Materials	
Insulating material	Through hole type: Polyester (UL94V-0) SMT type: PPS (UL94V-0)	
Conductor	Copper alloy	
Plating	Signal pin contact	Gold
	Signal pin tail	Palladium
	Power pin	Solder

■ APPLICATION EXAMPLE

1. Standard type

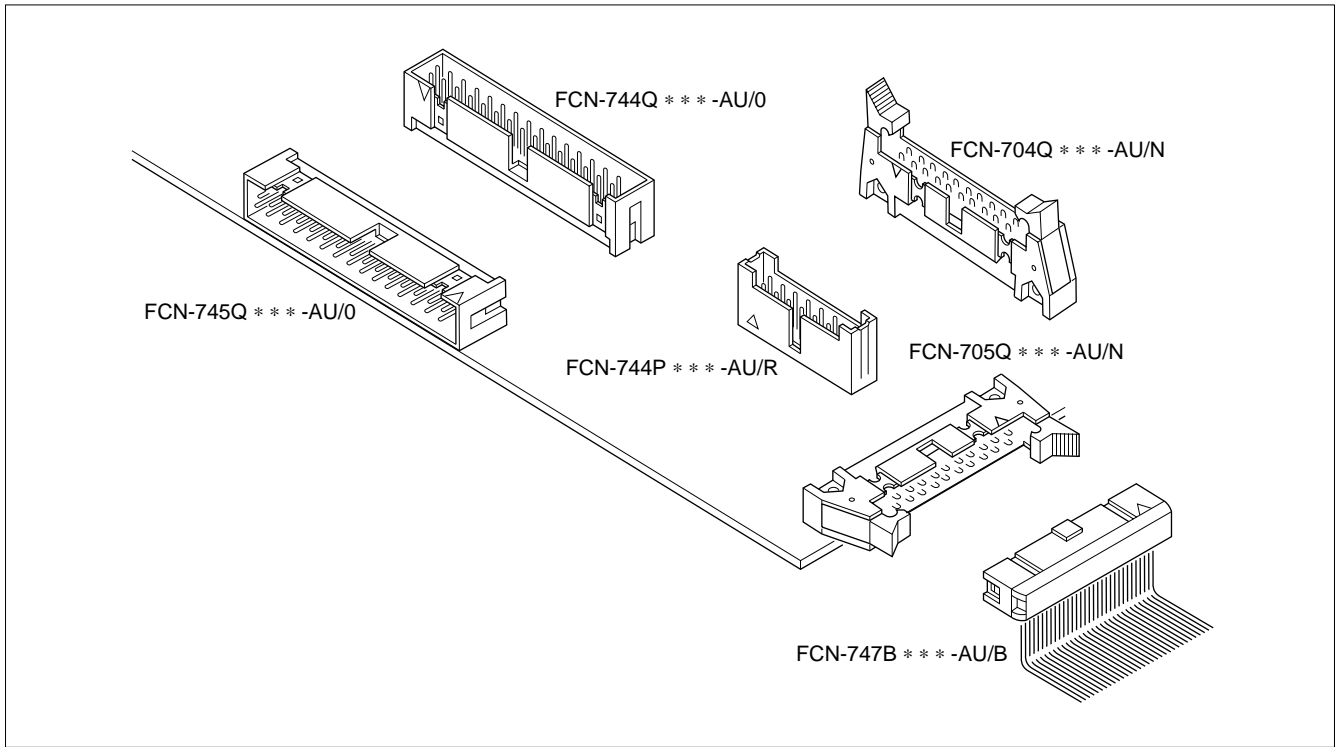

2. Power connector integrated type

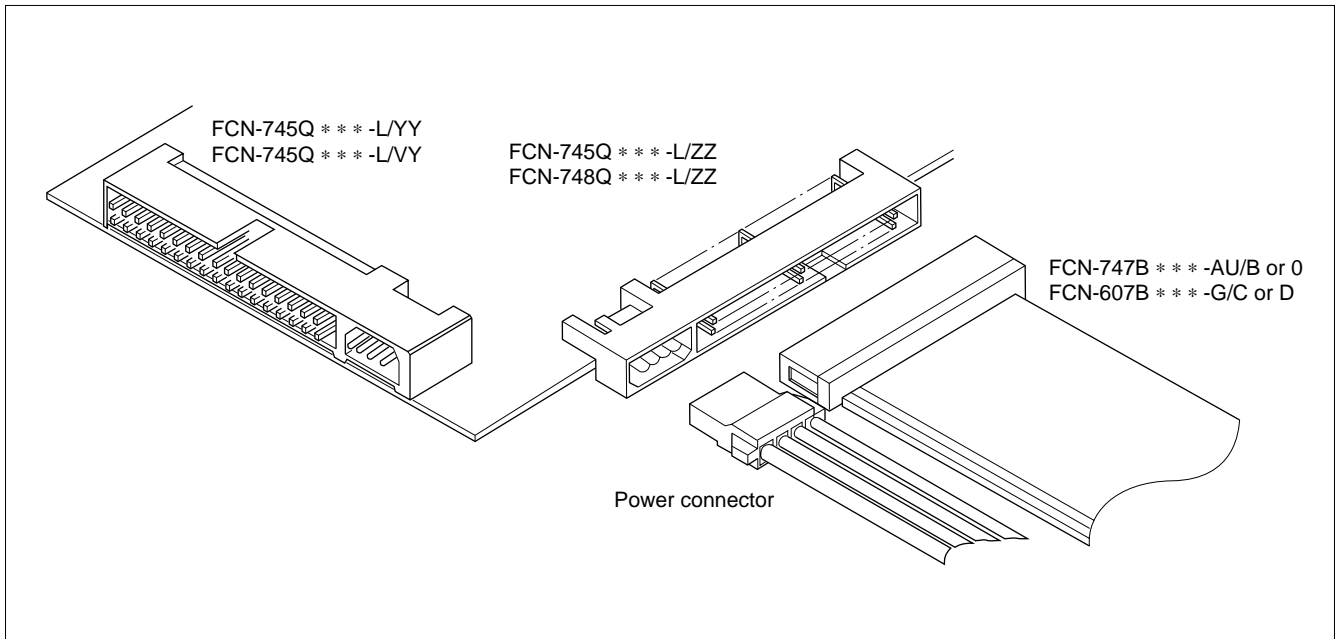

IDC SOCKET (CLIP TYPE, CLOSED END COVER)

■ DIMENSIONS

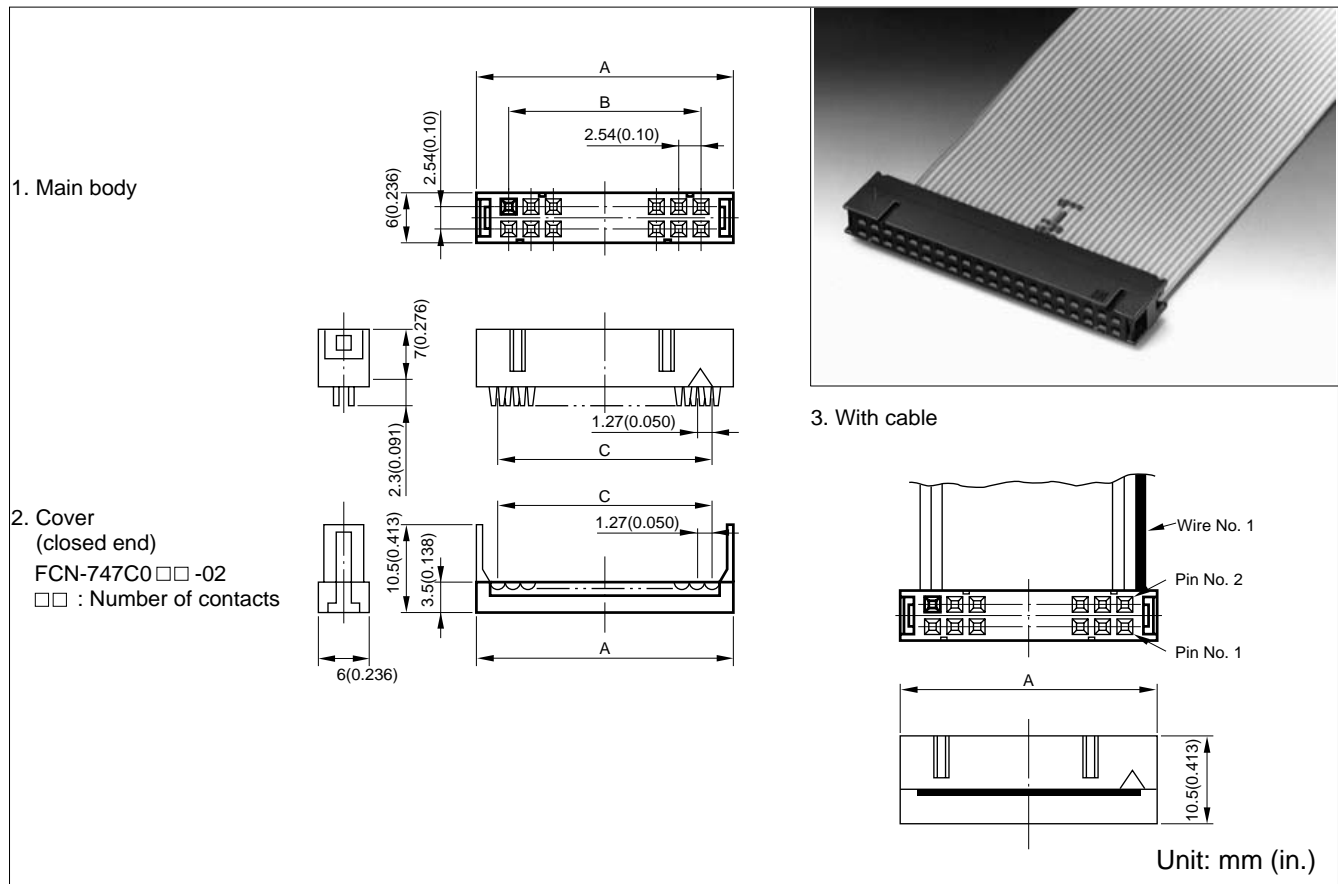

■ PART NUMBERS AND DIMENSIONS

Number of contacts	Part number	Dimensions (unit: mm (in.))			Min. purchase lot quality
		A	B	C	
10	FCN-747J010-AU/B	17.27 (0.680)	10.16 (0.400)	11.43 (0.450)	30
14	FCN-747J014-AU/B	22.35 (0.880)	15.24 (0.600)	16.51 (0.650)	23
16	FCN-747J016-AU/B	24.89 (0.980)	17.78 (0.700)	19.05 (0.750)	21
20	FCN-747J020-AU/B	29.97 (1.180)	22.86 (0.900)	24.13 (0.950)	17
24	FCN-747J024-AU/B	35.05 (1.380)	27.94 (1.100)	29.21 (1.150)	15
26	FCN-747J026-AU/B	37.59 (1.480)	30.48 (1.200)	31.75 (1.250)	14
30	FCN-747J030-AU/B	42.67 (1.680)	35.56 (1.400)	36.83 (1.450)	12
34	FCN-747J034-AU/B	47.75 (1.880)	40.64 (1.600)	41.91 (1.650)	11
40	FCN-747J040-AU/B	55.37 (2.180)	48.26 (1.800)	49.54 (1.950)	9
50	FCN-747J050-AU/B	68.07 (2.680)	60.96 (2.400)	62.23 (2.450)	7
60	FCN-747J060-AU/B	80.77 (3.180)	73.66 (2.900)	74.93 (2.950)	6

IDC SOCKET (CLIP TYPE, THROUGH END COVER)

■ DIMENSIONS

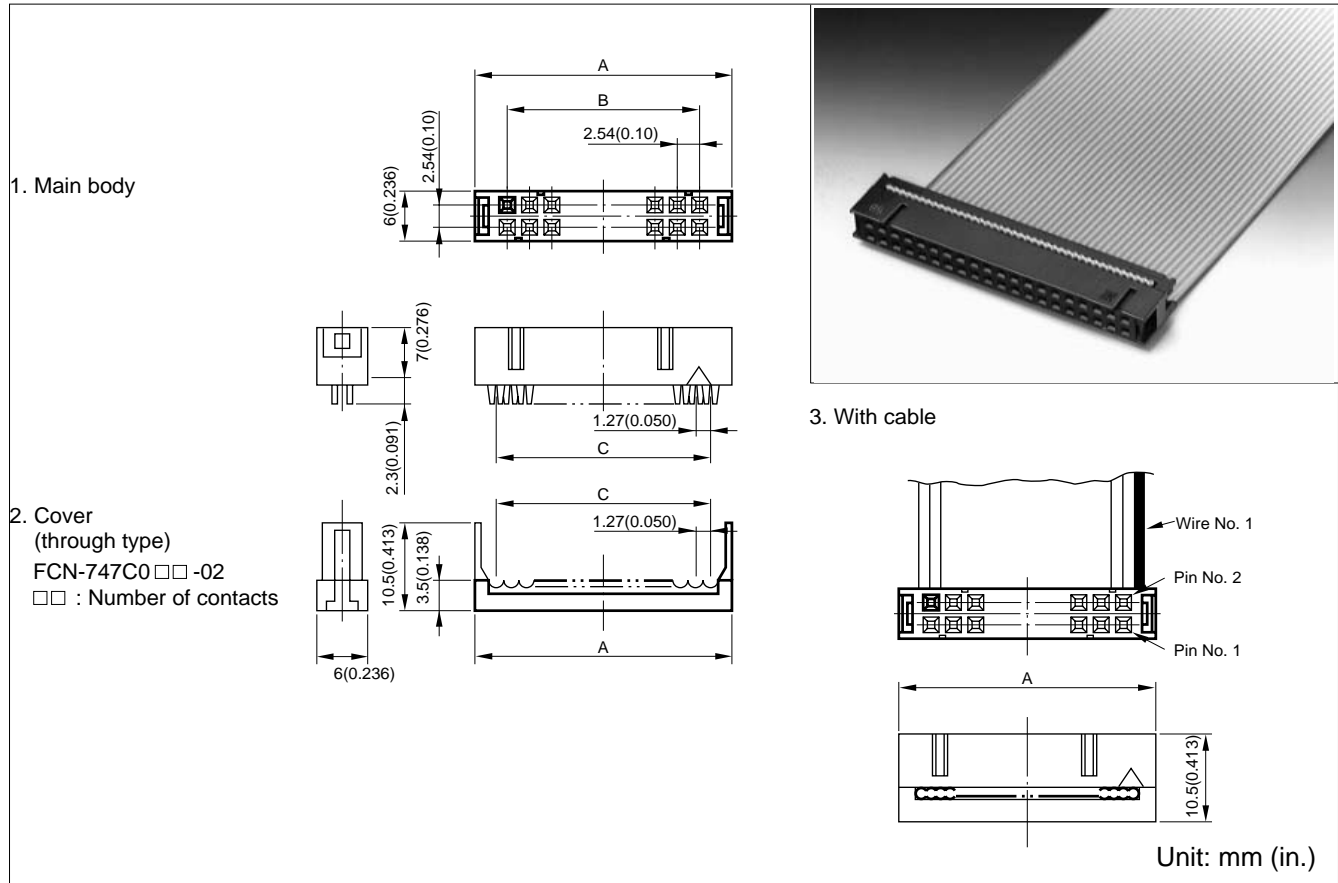

■ PART NUMBERS AND DIMENSIONS

Number of contacts	Part number	Dimensions (unit: mm (in.))			Min. purchase lot quality
		A	B	C	
10	FCN-747J010-AU/0	17.27 (0.680)	10.16 (0.400)	11.43 (0.450)	30
14	FCN-747J014-AU/0	22.35 (0.880)	15.24 (0.600)	16.51 (0.650)	23
16	FCN-747J016-AU/0	24.89 (0.980)	17.78 (0.700)	19.05 (0.750)	21
20	FCN-747J020-AU/0	29.97 (1.180)	22.86 (0.900)	24.13 (0.950)	17
24	FCN-747J024-AU/0	35.05 (1.380)	27.94 (1.100)	29.21 (1.150)	15
26	FCN-747J026-AU/0	37.59 (1.480)	30.48 (1.200)	31.75 (1.250)	14
30	FCN-747J030-AU/0	42.67 (1.680)	35.56 (1.400)	36.83 (1.450)	12
34	FCN-747J034-AU/0	47.75 (1.880)	40.64 (1.600)	41.91 (1.650)	11
40	FCN-747J040-AU/0	55.37 (2.180)	48.26 (1.800)	49.54 (1.950)	9
50	FCN-747J050-AU/0	68.07 (2.680)	60.96 (2.400)	62.23 (2.450)	7
60	FCN-747J060-AU/0	80.77 (3.180)	73.66 (2.900)	74.93 (2.950)	6

■ IDC TOOLS

- Special IDC tools are used to assemble FCN-740 series connectors and flat cables.
- All tools are simple and easy to use, even for first-time users.
- Users who have IDC tools manufactured by us do not have to buy hand presses or cut cables. They are compatible. Take care to buy the locator plate designed for your connectors.
- The number of pins can be changed easily by setting the connector guide to a specified pin hole.
- The cable cutter remains sharp, providing fast, easy cutting with long life.

Notes:

- Please ask for an operation instruction manual if needed.
- If you have any questions about Fujitsu IDC tools, please contact your local Fujitsu office or your local Fujitsu distributor.

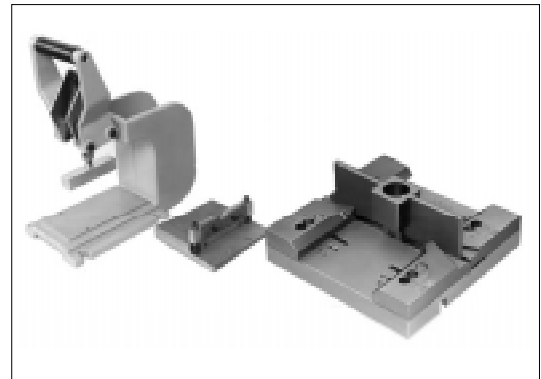

Hand press Cable cutter Locator plate (790 series)

■ CABLE TERMINATION

• Flat cable termination diagram

There are many ways to connect connectors to flat cables. Choose the connection method appropriate to your application from the figure below.

For 740 clip types, the connector orientation is important if polarity is specified to prevent incorrect insertion for 740 series clip types.

• Cable length

The length of a cable is indicated in units of cm, as shown in the figure below. The minimum length is 3 cm. The specified tolerance of the cable length is $\pm 10\%$ for $L \leq 10$ cm (± 5 mm min.), ± 1 cm for 10 cm $< L < 100$ cm, $\pm(L/100$ cm $+ 2$ cm) for 100 cm $\leq L \leq 1800$ cm, and ± 20 cm for 1800 cm $< L$.

Type number	No. 1	No. 2	No. 3	No. 4
Connector model				
740 series				

■ PART NUMBERS FOR IDC TOOLS

Name	Part number
Cable cutter (common)	FCN-707T-T001/H
Hand press (common)	FCN-707T-T101/H
Locator plate (for 740 series connectors)	FCN-747T-T018/H

The hand press and the cable cutter can be used for other IDC connectors.

■ SPECIFICATION OF POLARITY TO PREVENT INCORRECT INSERTION

• Specify polarity as follows:

• Header (pin type, clip type)

FCN-705P050-AU/N # □ □ △

Basic part number Common Pin number with pin polarity

Example

00: No polarity
When the A2 key is not used, only the basic part number is specified without a suffix.

04: Pin 4 is cut or pulled out.

Position of clip polarity (see the figure on the right)

• Socket (pin type)

FCN-747J050-AU/B # □ □

Basic part number Common Pin number with pin polarity

Example

04: FCN-700A1 plugged into pin 4

Note: The specification method is the same for IDC plugs and through hole sockets.

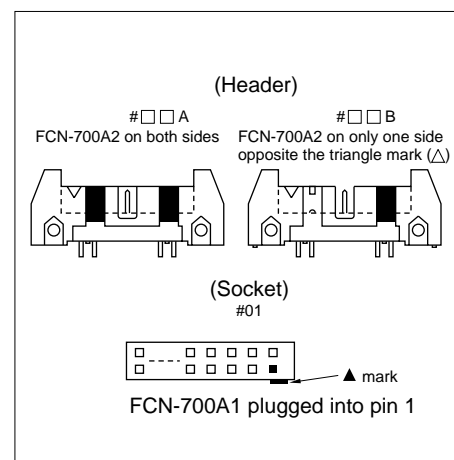

Note: The standard specification is #04 or the end pin number (if the end pin is 50, the specification is 50).