



Ap25 PANEL MOUNTING PRINTER RANGE Operator Information

There are two buttons on the front panel of the printer. One button operates the front door latch, the other controls the paper feed.

Door Latch:

With the printer mounted in data mode attitude (paper emerging downwards) so that the two control buttons are at upper left, to open the front door of the printer, press the door latch (the outermost of the two buttons) sideways towards the other button, using thumb or forefinger (see Figure 1). This will release the latch and the door can be swung outwards to expose the paper roll.

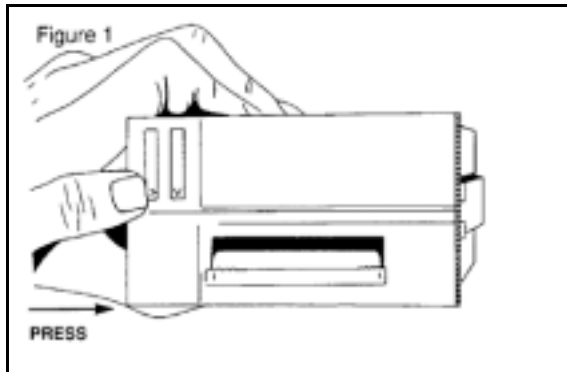

Paper Feed Button.

With the printer in data mode attitude press the top part of the innermost button to activate paper feed (see Figure 2). This will continue for as long as the button is held down.

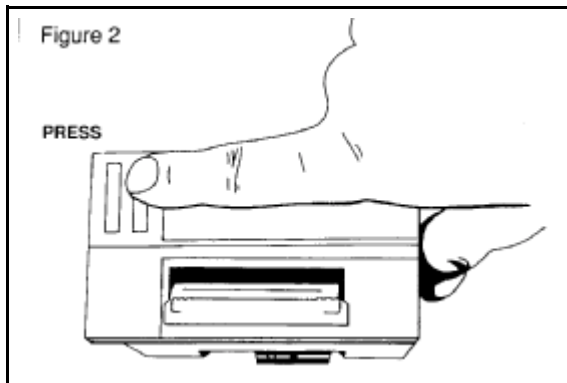

Paper Roll Replacement:

Open the printer door as described above and swing the door open to expose the paper roll. If any paper remains in the printer, tear the end off against the paper tear bar and carefully pull the remaining paper backwards, from the rear of the mechanism mounting chassis, until the free end emerges. Press the paper roll retaining button inwards using the thumb and forefinger (see figure 3) and remove the empty roll.

Take a new roll of paper, and separate the end from the rest of the roll. Remove any damaged or gummed part of the paper, and cut the free end squarely with a pair of scissors or a knife, leaving a clean straight edge to present to the printer mechanism.

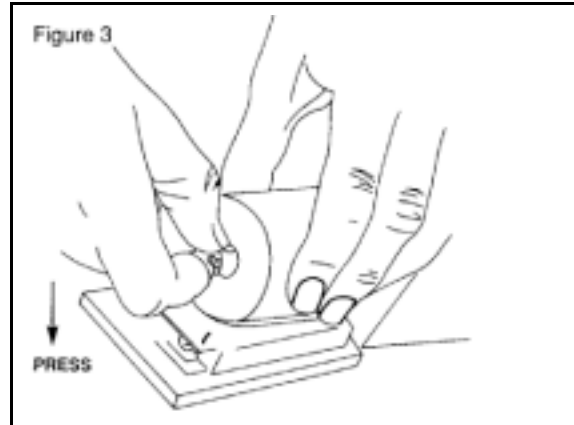

Thread the new roll past the retention button onto the spindle with the paper unspooling in an anticlockwise direction when viewed from the open end. (See Figure 4). Press the paper feed actuator arm (at upper left in data mode) until the mechanism grips the paper and pulls it through to the front of the printer. (See Figure 5).

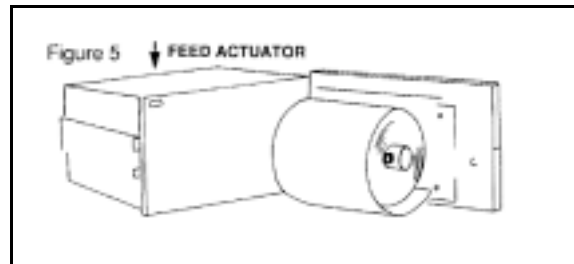
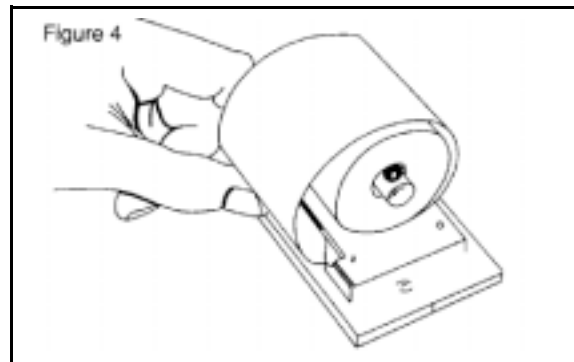

Turn the paper roll so that any loose turns are wound snugly against the roll. Close the printer door.

More paper may now be fed through by pressing the paper feed button on the front panel. (see Figure 2).

Ribbon Cartridge Replacement:

Tear off any paper emerging from the printer.
Open the printer door by pressing the door latch inwards.

Place forefinger against the lower edge of the mechanism mounting chassis and thumb against the base of the door (see Figure 6).

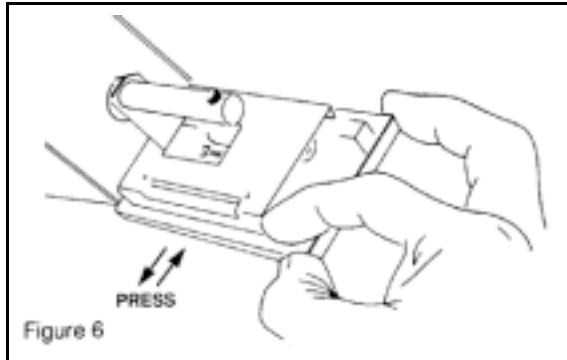

Carefully press the door and chassis in vertically opposite directions until the catch is released. Do not pull the door and chassis apart without first releasing the catch.

Swing the chassis back, leaving the door fully open. This will expose the printer mechanism and ink ribbon cartridge.

Press down on the end of the ink ribbon cartridge marked 'PUSH' (see Figure 7) and carefully remove the used cartridge.

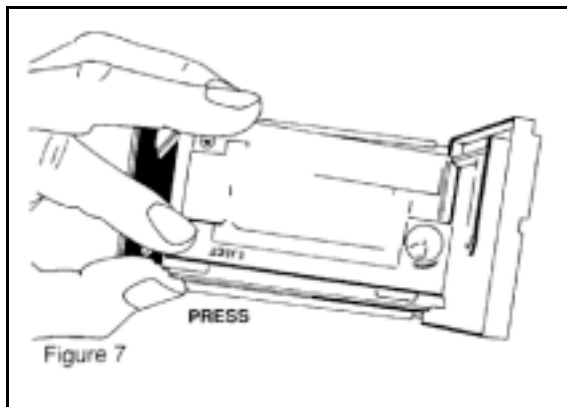

Fit a replacement cartridge, ensuring that the paper lies between the ribbon and the steel printer platen.

Check that the ribbon cartridge spindle is correctly seated over the printer ribbon drive shaft, and snap the cartridge into place.

Ensure that the ribbon is taut and parallel to the paper.

If necessary tighten the ribbon by turning the faceted disc clockwise using fingernail (see Figure 8).

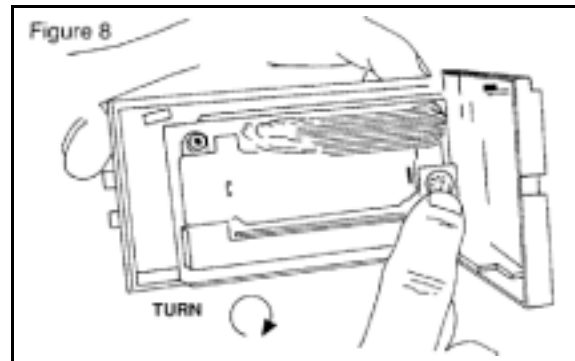

If there is some paper protruding from the front of the printer mechanism, ensure that it will pass clearly through the guide channel and past the tear bar before snapping the chassis shut against the back of the door.

Turn the paper roll by hand so that any loose turns are wound snugly against the roll.

Close the door and check that the paper flows freely, using the paper feed button.

Consumables available

A consumables pack (Stock No. A160CBP) is available containing five 19m rolls of paper and two Epson ribbon cartridges. Use of this paper is recommended, as most paper rolls from other sources are too large to fit within the printer housing, and may be of inferior quality causing dust and wear.



ABLE SYSTEMS LIMITED
DENTON DRIVE, NORTHWICH
CHESHIRE CW9 7TU
GB

TEL: 01606 48621
INTERNATIONAL: +44 606 48621
FAX: 01606 44903