

Solid State Relays Industrial, 3-Phase ZS Types RZ HD P., RZ HA P.



- 3-phase Solid State Relay
- Zero switching
- Rated operational current: 3 x 10, 25, 40 or 55 AACrms
- Rated operational voltage: Up to 690 VACrms
- Control voltage 10 to 40 VDC or 20 to 265 VAC/DC
- Transient overvoltage protection built-in
- Prepared for overtemperature protection
- Pilot duty switch available as an option
- IP 10 back-of-hand protection

Product Description

A Solid State Relay family designed to switch various loads such as heating elements, motors and transformers. The relay is capable of switching high voltages up to 690 VACrms.

Technique

For higher reliability and load cycle capability three alternistor chips are soldered directly on to the direct copper bonded (DCB) substrate. AC-

or DC-controlled versions are available. Built-in LED status indication for applied control voltage. Other features include overvoltage protection via the varistors and the possibility of installing a thermostat for overtemperature protection. When equipped with a pilot duty switch and connected to a mechanical relay a hybrid function is achieved, and it is no longer necessary to use a heatsink.

Ordering Key

R Z 40 25 HD P0

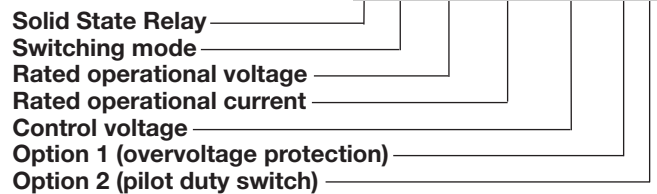

Type Selection

Switching mode	Rated operational voltage	Rated operational current	Control voltage	Option 1 (protection)	Option 2 (pilot duty switch)
RZ	40: 400 VACrms 48: 480 VACrms	10: 10 AACrms 25: 25 AACrms 40: 40 AACrms 55: 55 AACrms	HD: 10 - 40 VDC HA: 20 - 265 VAC/DC	P: Protected J: Unprotected	0: Without PDS 1: 1 A/230 VAC 2: 1 A/24 VDC

Selection Guide

Rated operational voltage	Control voltage	Rated operational current			
		10 AACrms	25 AACrms	40 AACrms	55 AACrms
400 VACrms	10 - 40 VDC	RZ 4010 HD P.	RZ 4025 HD P.	RZ 4040 HD P.	RZ 4055 HD P.
	20 - 265 VAC/DC	RZ 4010 HA P.	RZ 4025 HA P.	RZ 4040 HA P.	RZ 4055 HA P.
480 VACrms	10 - 40 VDC	RZ 4810 HD P.	RZ 4825 HD P.	RZ 4840 HD P.	RZ 4855 HD P.
	20 - 265 VAC/DC	RZ 4810 HA P.	RZ 4825 HA P.	RZ 4840 HA P.	RZ 4855 HA P.

Options

- 1 Protection: unprotected version only available on request.
- 2 Pilot duty switch: add suffix 1 or 2 for pilot duty switch (e.g. 1 A/230 VAC). Example: RZ 4025 HDP1.
Ordering example for RZ-relay with built-in varistors and pilot duty switch: RZ 4025 HDP1.

General Specifications

	RZ 40... P.	RZ 48... P.
Operational voltage ranges Line to neutral Line to line (load connected to neutral)	12 to 440 VACrms 12 to 400 VACrms	12 to 530 VACrms 12 to 660 VACrms
Non-rep. peak voltage	$\geq 1000 V_p$	$\geq 1200 V_p$
Varistor voltage	420 VACrms	510 VACrms
Operational frequency range	45 to 65 Hz	45 to 65 Hz
Overtoltage category	III	III
Pollution degree	3	2
Approvals	CSA, UL	CSA, UL
CE-marking	Yes	Yes

Star
(load connected to neutral)

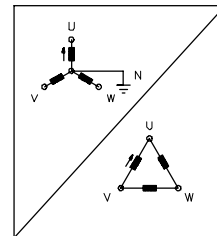

Delta

Input Specifications

	RZ HD P0	RZ HA P0	RZ HD P2	RZ HA P1
Control voltage range	10 to 40 VDC FELV-SELV-PELV	20 to 265 VAC/DC FELV-SELV- PELV/line	10 to 40 VDC FELV-SELV-PELV	20 to 265 VAC/DC FELV-SELV- PELV/line
Pick-up voltage	≤ 10 VDC	≤ 20 VAC/DC	≤ 10 VDC	≤ 20 VAC/DC
Drop-out voltage	≥ 3 VDC	≥ 5 VAC/DC	≥ 3 VDC	≥ 5 VAC/DC
Input current	≤ 18 mADC @ $10 V_{in}$ ≤ 22 mADC @ $24 V_{in}$ ≤ 28 mADC @ $40 V_{in}$	≤ 20 mA AC/DC	≤ 18 mADC @ $10 V_{in}$ ≤ 30 mADC @ $24 V_{in}$ ≤ 40 mADC @ $40 V_{in}$	≤ 20 mA AC/DC
Response time pick-up Power output Pilot duty switch	≤ 10 ms - -	≤ 10 ms - -	≤ 10 ms ≤ 10 ms	≤ 10 ms ≤ 10 ms
Response time drop-out Power output Pilot duty switch	≤ 20 ms - -	≤ 40 ms - -	≤ 100 ms ≤ 10 ms	≤ 100 ms ≤ 20 ms

Output Specifications

	RZ ..10 .. P.	RZ ..25 .. P.	RZ ..40 .. P.	RZ ..55 .. P.
Rated operational current AC1 ratings AC3 ratings	10 Arms 2 Arms	25 Arms 5 Arms	40 Arms 8 Arms	55 Arms 15 Arms
Minimum operational current	100 mArms	100 mArms	200 mArms	200 mArms
Rep. overload current $t=1$ s $t=5$ s	≤ 18 Arms ≤ 15 Arms	≤ 37 Arms ≤ 32 Arms	≤ 60 Arms ≤ 50 Arms	≤ 85 Arms ≤ 70 Arms
Non-rep. surge current $t = 20$ ms	$120 A_p$	$230 A_p$	$300 A_p$	$550 A_p$
Off-state leakage current	≤ 10 mArms	≤ 10 mArms	≤ 10 mArms	≤ 10 mArms
I^2t for fusing $t = 1-10$ ms	$\leq 72 A^2s$	$\leq 265 A^2s$	$\leq 450 A^2s$	$\leq 1500 A^2s$
Critical dI/dt	$\geq 50 A/\mu s$	$\geq 50 A/\mu s$	$\geq 100 A/\mu s$	$\geq 100 A/\mu s$
On-state voltage drop	≤ 1.6 Vrms	≤ 1.6 Vrms	≤ 1.6 Vrms	≤ 1.6 Vrms
Critical dV/dt off state	$\geq 500 V/\mu s$	$\geq 500 V/\mu s$	$\geq 500 V/\mu s$	$\geq 500 V/\mu s$



Thermal Specifications

	RZ ..10 ..	RZ ..25 ..	RZ ..40 ..	RZ ..55 ..
Operating temperature	-20° to +70°C (-4° to +158°F)	-20° to +70°C (-4° to +158°F)	-20° to +70°C (-4° to +158°F)	-20° to +70°C (-4° to +158°F)
Storage temperature	-40° to +100°C (-40° to +212°F)	-40° to +100°C (-40° to +212°F)	-40° to +100°C (-40° to +212°F)	-40° to +100°C (-40° to +212°F)
Junction temperature	≤ 125°C (≤ 257°F)	≤ 125°C (≤ 257°F)	≤ 125°C (≤ 257°F)	≤ 125°C (≤ 257°F)
R _{th} junction to case 3-phase	0.75 K/W	0.5 K/W	0.3 K/W	0.2 K/W
1-phase	2.25 K/W	1.5 K/W	1.0 K/W	0.6 K/W

Option 1 - Overvoltage Protection

Transients are generated by overvoltage of atmospheric origin on the public distribution system or when motors, solenoids, valves, lights, heaters or any electrically operated equipment are connected to or disconnected from the power source. To perform a transient voltage clipping or suppression func-

tion on the AC-load side of an RZ relay, metal oxide varistors (MOV) are normally built in. MOV's assume a low impedance state when their voltage threshold is exceeded. Carlo Gavazzi SSR's are optionally available without varistors if no transient protection is required.

Insulation

	ACrms 3 cycles	ACrms 1 min
Rated insulation voltage		
Input to output	≥ 5660 V	≥ 4000 V
Input to pilot duty switch	≥ 5660 V	≥ 4000 V
Input to heatsink	≥ 5660 V	≥ 4000 V
Rated insulation voltage		
Output to heatsink	≥ 4240 V	≥ 4000 V
Output to output	≥ 4240 V	≥ 4000 V
Output to pilot duty switch	≥ 4240 V	≥ 4000 V

Option 2 - Pilot Duty Switch

The RZ relay is available either with or without pilot duty switch (PDS). Equipped with the PDS and connected to a mechanical relay, a hybrid function is achieved and it is no longer necessary to use a heatsink. The built-in timing function of the relay will ensure that the switching on and switching off is carried out by the Solid State Relay. As soon as the control voltage is applied, the power output turns on and the full voltage is applied to

the load. After max. 10 ms, the PDS will activate the contactor shunting the SSR in about 20 ms. As the load is already under full voltage, the contactor does not take any high inrush currents. It only bypasses the SSR. When the control voltage is removed, the pilot duty switch will first disconnect the contactor. After a delay of min. 30 ms, the load will be switched off. The power outputs will be off max. 100 ms after the input control voltage has been removed.

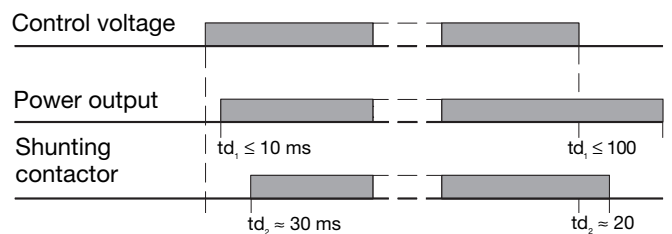

td₁ = time delay semiconductor
td₂ = time delay contactor

	PDS 01	PDS 02
Operational voltage range	24 to 280 VACrms	5 to 24 VDC
Rated operational current	≤ 1 Arms @ 40°C ≤ 0.85 Arms @ 50°C ≤ 0.7 Arms @ 60°C ≤ 0.55 Arms @ 70°C	≤ 1 A @ 40°C ≤ 0.85 A @ 50°C ≤ 0.7 A @ 60°C ≤ 0.5 A @ 70°C
Non-rep. surge current t = 20 ms	30 A _p	-
Rep. overload current t = 1s	5 Arms	2 A DC
I ² t for fusing t=1-10 ms	5 A ² s	-
Off-state leakage current	≤ 1 mArms	≤ 1 mA DC
On-state voltage	1.2 VACrms	1.5 VDC



Heatsink Dimensions (load current versus ambient temperature)

RZ ..10.. ..

Load current [A]	Thermal resistance [K/W]					Power dissipation [W]	Temp. protection [°C]
	20	30	40	50	60		
12	1.7	1.4	1.2	1.0	0.7	41	90°C
11	2.0	1.7	1.4	1.2	0.9	37	
10	2.3	2.0	1.7	1.4	1.1	33	
9	2.7	2.4	2.0	1.7	1.3	29	
8	3.1	2.7	2.3	1.9	1.5	25	
7	3.7	3.2	2.7	2.3	1.8	21	
6	4.4	3.8	3.3	2.7	2.2	18	
5	5.4	4.7	4.1	3.4	2.7	15	
4	7.0	6.1	5.2	4.3	3.5	12	
3	9.5	8.3	7.1	5.9	4.7	8	
2	14.7	12.9	11.0	9.2	7.3	5	

T_A
Ambient temp [°C]

RZ ..25.. ..

Load current [A]	Thermal resistance [K/W]					Power dissipation [W]	Temp. protection [°C]
	20	30	40	50	60		
25	0.46	0.36	0.26	-	-	101	70°C
22.5	0.62	0.50	0.39	0.28	-	88	80°C
20	0.81	0.68	0.55	0.42	0.28	76	
17.5	1.0	0.91	0.76	0.60	0.44	64	90°C
15	1.4	1.2	1.0	0.85	0.66	53	
12.5	1.9	1.6	1.4	1.1	0.95	43	
10	2.4	2.1	1.8	1.5	1.2	33	
7.5	3.4	3.0	2.5	2.1	1.7	24	
5	5.3	4.7	4.0	3.3	2.6	15	
2.5	11.2	9.8	8.4	7.0	5.6	7	

T_A
Ambient temp [°C]

RZ ..40.. ..

Load current [A]	Thermal resistance [K/W]					Power dissipation [W]	Temp. protection [°C]
	20	30	40	50	60		
40	0.26	-	-	-	-	165	70°C
36	0.36	0.29	-	-	-	143	80°C
32	0.49	0.40	0.32	-	-	122	
28	0.65	0.55	0.46	0.36	0.26	103	90°C
24	0.87	0.76	0.64	0.52	0.40	84	
20	1.2	1.1	0.90	0.75	0.60	67	
16	1.5	1.4	1.2	1.0	0.78	51	
12	2.2	2.0	1.7	1.4	1.1	37	
8	3.5	3.1	2.7	2.2	1.8	23	
4	7.4	6.5	5.6	4.6	3.7	11	

T_A
Ambient temp [°C]

RZ ..55.. ..

Load current [A]	Thermal resistance [K/W]					Power dissipation [W]	Temp. protection [°C]
	20	30	40	50	60		
55	-	-	-	-	-	215	80°C
50	0.28	-	-	-	-	191	
45	0.35	0.29	-	-	-	167	90°C
40	0.45	0.38	0.31	-	-	145	
35	0.58	0.50	0.42	0.33	0.25	123	
30	0.75	0.65	0.55	0.46	0.36	103	
25	0.96	0.84	0.72	0.60	0.48	83	
20	1.3	1.1	0.93	0.78	0.62	65	
15	1.8	1.5	1.3	1.1	0.85	47	
10	2.7	2.4	2.0	1.7	1.4	30	
5	5.5	4.8	4.1	3.5	2.8	15	

T_A
Ambient temp [°C]

Heatsink Selection

Carlo Gavazzi Heatsink (see Accessories)	Thermal resistance
No heatsink required	$R_{th\ s-a} > 8.0$ K/W
RHS 300 Assy or backplate	5.0 K/W
RHS 301 Assy	0.8 K/W
RHS 301 F Assy	0.25 K/W
Consult your distributor	< 0.25 K/W

Compare the value found in the load current versus temperature chart with the standard heatsink values and select the heatsink with the next lower value.

It is recommended to protect the Solid State Relay against overheating. Therefore the chart also states the maximum switching temperature (70, 80 or 90°C) for the optional temperature limit switch.

Functional Diagram

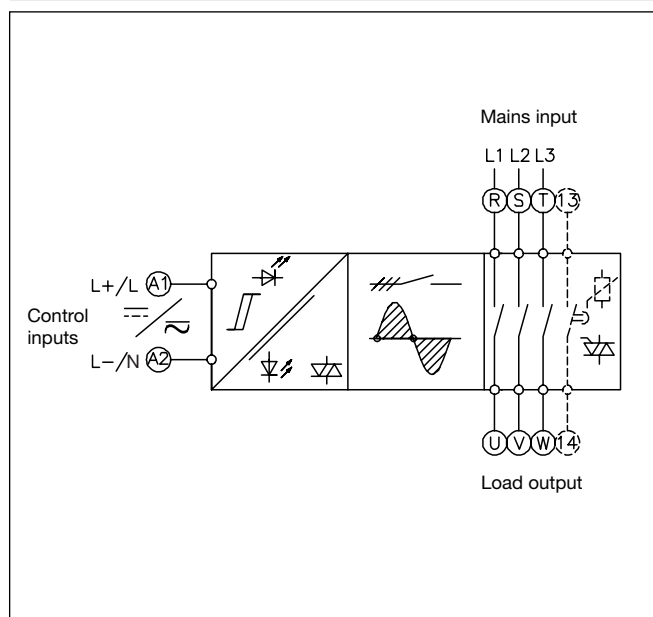

Dimensions

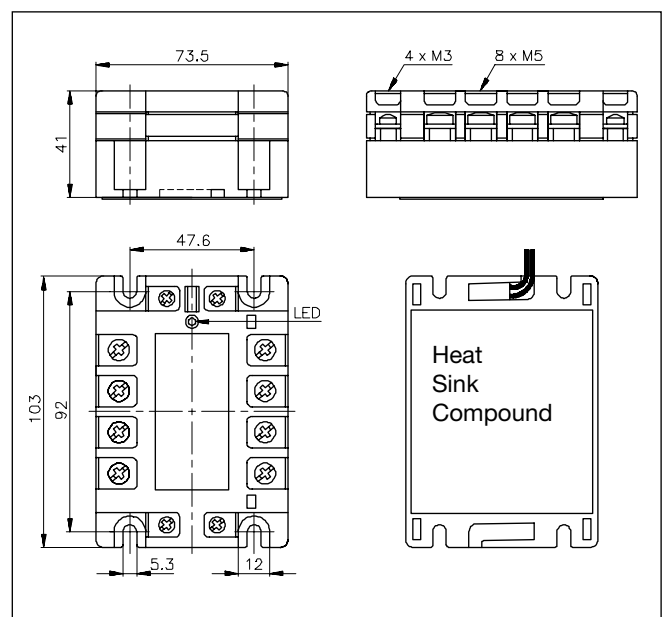

Housing Specifications

Weight	Approx. 380 g	
Material	Noryl, glass reinforced	
Colour	Black	
Base plate	Aluminum, nickel-plated	
Potting compound	Polyurethane, black	
Relay		
Mounting screws	M5	
Mounting torque	≤ 1.5 Nm	
Control terminal		
Mounting screws	M3	
Mounting torque	≤ 0.5 Nm	
Wire size	Max.	2 x 2.5 mm ²
	Min.	2 x 1.0 mm ²
Power terminal		
Mounting screws	M5	
Mounting torque	≤ 2.5 Nm	
	2 x 6 mm ² (AWG8)	
Wire size	Max.	2 x 6 mm ²
	Min.	2 x 1 mm ²

Accessories

- Protection cover
- Heatsinks
- Varistors
- Fuses
- Temperature limit switch

For further information refer to "General Accessories".

Applications

Switching motor loads

Direct switching

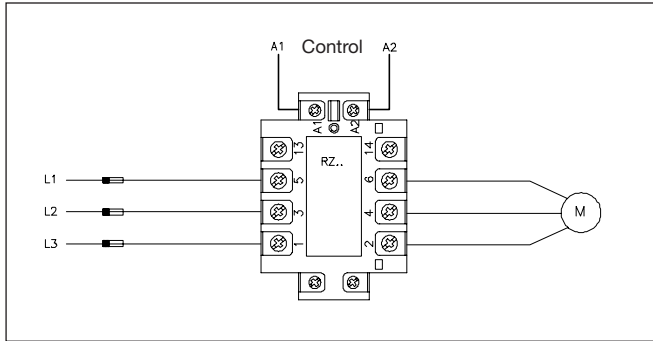

Selection Guide

380/400 V		Relay type [A]			
Motor size [kW]	[Arms]	10	25	40	55
0.25	0.8				
0.37	1.1				
0.55	1.5				
0.75	1.9				
1.1	2.6				
1.5	3.5				
2.2	4.7				
3.0	6.2				
4.0	8.1				
5.5	10.7				
7.5	15.0				

Delta switching

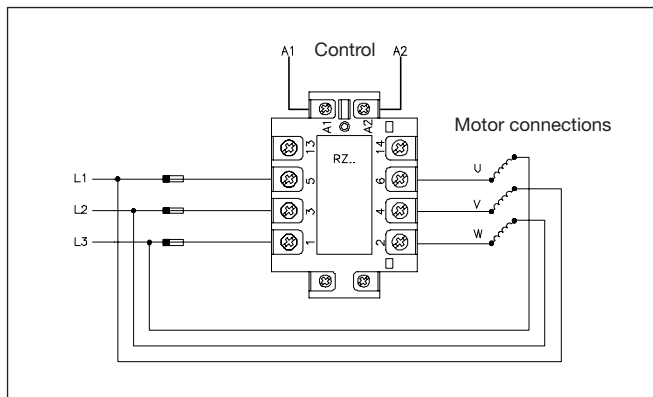

Selection Guide

380/400 V		Relay type [A]			
Motor size [kW]	[Arms]*	10	25	40	55
1.1	1.5				
1.5	2.1				
2.2	3.0				
3.0	4.0				
4.0	4.6				
5.5	6.2				
7.5	8.7				
11.0	12.1				
15.0	16.2				

* $I/\sqrt{3}$.

Motor start with shunting by electromechanical relay (no heatsink needed)

Direct switching

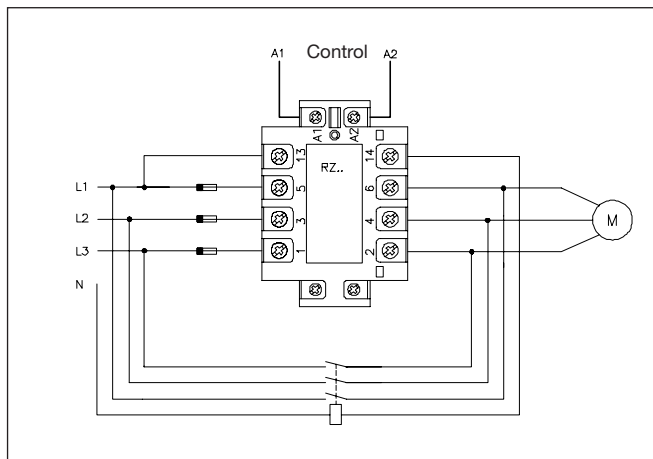

Selection Guide

380/400 V		Relay type [A]			
Motor size [kW]	[Arms]	10	25	40	55
3.0	7.0				
5.5	11.9				
7.5	15.3				
15	29				