

THIS DRAWING IS UNPUBLISHED. RELEASED FOR PUBLICATION
 © COPYRIGHT BY TYCO ELECTRONICS CORPORATION. ALL INTERNATIONAL RIGHTS RESERVED.

LOC	DIST	REVISIONS					
FT	0	P	LTR	DESCRIPTION	DATE	DWN	APVD
		AB		REVISED PER ECO-08-028385	25NOV08	HMR	BC

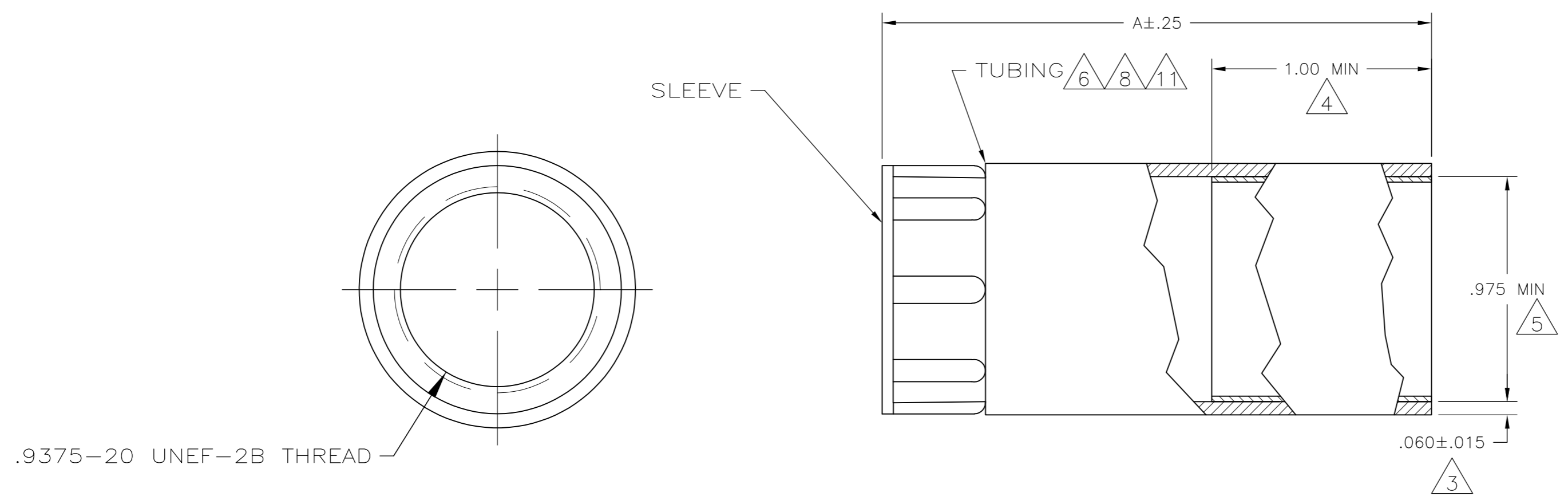

- 1 POLYOLEFIN, BLACK.
- 2 NYLON, BLACK.
- 3 NOMINAL WALL THICKNESS, EXPANDED.
- 4 LENGTH OF SEALANT.
- 5 EXPANDED INSIDE DIAMETER.
- 6 9.52[.375] MAXIMUM RECOVERED INSIDE DIAMETER.
- 7 ASSEMBLY WILL PASS 0.0703 KG PER SQ CENTIMETER [ONE POUND PER SQ IN.] WATER PRESSURE TEST.
- 8 121°C [250°F] SHRINK TEMPERATURE.
- 9 -55°C TO 110°C [-67°F TO 230°F] OPERATING TEMPERATURE.
- 10 THIS PART WILL ACCOMODATE $\phi 10.16 - \phi 22.22$ [$\phi 400 - \phi 875$] CABLE RANGE.
- 11 ACTUAL SHAPE MAY VARY DUE TO PROCESS VARIANCE.

4.00	54011-4
3.25	54011-3
2.50	54011-1
A	PART NUMBER

THIS DRAWING IS A CONTROLLED DOCUMENT.		DWN C.REIFSNYDER 10 APR 96	Tyco Electronics Corporation Harrisburg, PA 17105-3608	
DIMENSIONS: INCHES		CHK R.STONE 15 APR 95	NAME STRAN RELIEF ASSY, SHELL SIZE 17, CPC	
TOLERANCES UNLESS OTHERWISE SPECIFIED:		APVD T.A.WETZEL 03 MAY 96	SIZE A2	CAGE CODE 00779
0 PLC ± -		PRODUCT SPEC	DRAWING NO C=54011	RESTRICTED TO
1 PLC ± -		APPLICATION SPEC	SCALE 2:1	SHEET 1 of 1
2 PLC ± -		WEIGHT	REV AB	
3 PLC ± -		CUSTOMER DRAWING		
4 PLC ± -				
ANGLES ± -				
FINISH				
MATERIAL TUBING: 1 SLEEVE: 2				

54011

A