

## 1 13/16" (46 mm) Ten Turn Wirewound, Bushing Mount



### FEATURES

- Gangable up to 2 sections
- Large range of ohmic values: 20  $\Omega$  to 200 k $\Omega$
- Extra taps available upon request
- Ideally suits for all industry applications

<b>ELECTRICAL SPECIFICATIONS</b>		
PARAMETER		
Total Resistance Standard Range Tolerance: 200 $\Omega$ and Above Below 200 $\Omega$	20 $\Omega$ to 200 k $\Omega$ <b>STANDARD</b> $\pm 3\%$ $\pm 5\%$	Special up to 500 k $\Omega$ <b>SPECIAL</b> $\pm 1\%$ $\pm 3\%$
Linearity (Independent)	$\pm 0.25\%$ standard	
20 $\Omega$ to 50 $\Omega$ 50 $\Omega$ to 200 $\Omega$ 200 $\Omega$ to 5 k $\Omega$ 5 k $\Omega$ and Above	$\pm 0.15\%$ $\pm 0.10\%$ $\pm 0.05\%$ $\pm 0.025\%$	
Noise	100 $\Omega$ ENR	
Electrical Angle	3600° + 4° - 0°	
Power Rating	8.0 W at 40 °C derated to zero at 125 °C	
Insulation Resistance	1000 M $\Omega$ minimum 500 V <sub>DC</sub>	
Dielectric Strength	1000 V <sub>RMS</sub> , 60 Hz	
Absolute Minimum Resistance	Not to exceed linearity x total resistance or 1 $\Omega$ , whichever is greater	
End Voltage	0.5 % of total applied voltage maximum	
Phasing	CCW end points sect. 2 phased to sect 1 within 1°	
Taps (Extra)	Available as special standard tolerance $\pm 1^\circ$	

<b>ORDERING INFORMATION/DESIGNATION</b>				
Model 860 can be ordered from this data sheet with a variety of alternate characteristics, as shown. For most rapid service on your order, please state:				
<b>860</b>	<b>B</b>	<b>1</b>	<b>20K</b>	<b>BO10</b>
MODEL	BUSHING MOUNT	NUMBER OF SECTIONS	RESISTANCE OF EACH SECTION	PACKAGING
		From 1 up to 2 sections (maximum)	Beginning with the section nearest the mounting end	Box of 10 pieces

<b>SAP PART NUMBERING GUIDELINES</b>				
<b>860</b>	<b>B</b>	<b>1</b>	<b>203</b>	<b>B10</b>
MODEL	STYLE	NUMBER OF SECTIONS	OHMIC VALUE OF SECTION N° 1	PACKAGING

# Model 860



Vishay Spectrol

1 13/16" (46 mm) Ten Turn Wirewound,  
Bushing Mount

**DIMENSIONS** in inches (millimeters)

## MODEL 860

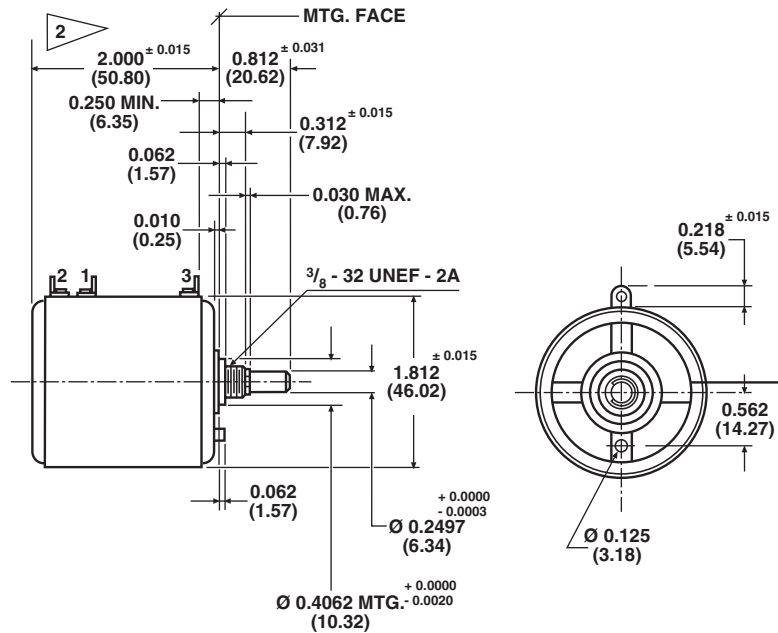

1 ADD 1.787 ± 0.010 (45.39) FOR 2 GANG UNIT

TOLERANCES: OTHERWISE NOTED.  
DECIMALS ± 0.005 ANGLES ± 2°

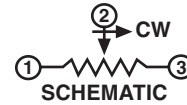

MECHANICAL SPECIFICATIONS		
PARAMETER		
Rotation	3600° + 4° - 0°	
Bearing Type	Sleeve bearing	
Torque (maximums): Section 1 Section 2	<b>STARTING</b> 1.75 oz. - in (126.02 g - cm) 2.55 oz. - in (183.62 g - cm)	<b>RUNNING</b> 1.26 oz. - in (90.01 g - cm) 1.85 oz. - in (133.21 g - cm)
Runouts (Maximums) Shaft (TIR) Pilot Dia (TIR) Lateral (TIR) Shaft End Play Shaft Radial Play	0.002" (0.05 cm) 0.002" (0.05 cm) 0.005" (0.13 cm) 0.002" min. 0.010" max. (0.05 - 0.25 cm) 0.003" max. (0.08 cm)	
Weight (maximums) Single Section Additional Section	4.5 oz. (127.58 g) 4.0 oz. (113.40 g)	
Stop Strength	750 oz. - in (static) (54.01 kg - cm)	
Ganging	2 sections maximum ears of clamp band between sections positioned 45°, ± 10° CCW from terminal center line	
Moment Inertia	15.0 g - cm <sup>2</sup> maximum	



**1 13/16" (46 mm) Ten Turn Wirewound,  
Bushing Mount**

Vishay Spectrol

MATERIAL SPECIFICATIONS	
Bushing	Aluminum, nickel plated
Housing and Front Lid	Molded glass filled thermoset plastic
Rear Lid	Molded glass filled nylon
Shaft	Stainless steel, non magnetic, non-passivated
Terminals	Brass, plated for solderability
Mounting Hardware Lockwasher: Panel Nut:	Internal tooth steel, nickel plated Brass, nickel plated

ENVIRONMENTAL SPECIFICATIONS	
Vibration	10 g thru 500 CPS
Shock	50 g
Rotational Life	500 000 shaft revolutions
Load Life	900 h
Temperature Range	- 55 °C to + 125 °C
Salt Spray	48 h

MARKING	
Unit Identification	Units will be marked with Vishay Spectrol name and model no, resistance and resistance tolerance, linearity, terminal identification, and date code

**POWER RATING CHART**

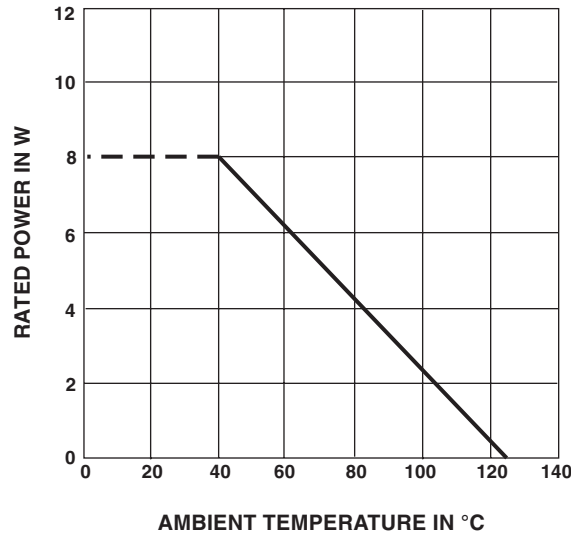

RESISTANCE ELEMENT DATA					
STANDARD RESISTANCE VALUES (Ω)	RESOLUTION (%)	OHMS PER TURN	MAXIMUM CURRENT AT 70 °C AMBIENT (mA)	MAXIMUM VOLTAGE ACROSS COIL (V)	WIRE TEMPERATURE COEFFICIENT (ppm/°C)
20	0.044	0.009	632	13	800
50	0.027	0.014	400	20	800
100	0.024	0.024	283	28	800
200	0.028	0.056	200	40	180
500	0.023	0.115	126	63	20
1K	0.018	0.182	89	89	20
2K	0.020	0.402	63	126	20
5K	0.015	0.754	40	200	20
10K	0.013	1.23	28	283	20
20K	0.010	1.97	20	400	20
50K	0.007	3.69	13	632	20
100K	0.007	6.51	8.9	894	20
200K	0.005	9.63	5.0	1000	20
500K	0.004	20.0	2.0	1000	20



## Disclaimer

ALL PRODUCT, PRODUCT SPECIFICATIONS AND DATA ARE SUBJECT TO CHANGE WITHOUT NOTICE TO IMPROVE RELIABILITY, FUNCTION OR DESIGN OR OTHERWISE.

Vishay Intertechnology, Inc., its affiliates, agents, and employees, and all persons acting on its or their behalf (collectively, "Vishay"), disclaim any and all liability for any errors, inaccuracies or incompleteness contained in any datasheet or in any other disclosure relating to any product.

Vishay makes no warranty, representation or guarantee regarding the suitability of the products for any particular purpose or the continuing production of any product. To the maximum extent permitted by applicable law, Vishay disclaims (i) any and all liability arising out of the application or use of any product, (ii) any and all liability, including without limitation special, consequential or incidental damages, and (iii) any and all implied warranties, including warranties of fitness for particular purpose, non-infringement and merchantability.

Statements regarding the suitability of products for certain types of applications are based on Vishay's knowledge of typical requirements that are often placed on Vishay products in generic applications. Such statements are not binding statements about the suitability of products for a particular application. It is the customer's responsibility to validate that a particular product with the properties described in the product specification is suitable for use in a particular application. Parameters provided in datasheets and/or specifications may vary in different applications and performance may vary over time. All operating parameters, including typical parameters, must be validated for each customer application by the customer's technical experts. Product specifications do not expand or otherwise modify Vishay's terms and conditions of purchase, including but not limited to the warranty expressed therein.

Except as expressly indicated in writing, Vishay products are not designed for use in medical, life-saving, or life-sustaining applications or for any other application in which the failure of the Vishay product could result in personal injury or death. Customers using or selling Vishay products not expressly indicated for use in such applications do so at their own risk and agree to fully indemnify and hold Vishay and its distributors harmless from and against any and all claims, liabilities, expenses and damages arising or resulting in connection with such use or sale, including attorneys fees, even if such claim alleges that Vishay or its distributor was negligent regarding the design or manufacture of the part. Please contact authorized Vishay personnel to obtain written terms and conditions regarding products designed for such applications.

No license, express or implied, by estoppel or otherwise, to any intellectual property rights is granted by this document or by any conduct of Vishay. Product names and markings noted herein may be trademarks of their respective owners.

## Material Category Policy

**Vishay Intertechnology, Inc. hereby certifies that all its products that are identified as RoHS-Compliant fulfill the definitions and restrictions defined under Directive 2011/65/EU of The European Parliament and of the Council of June 8, 2011 on the restriction of the use of certain hazardous substances in electrical and electronic equipment (EEE) - recast, unless otherwise specified as non-compliant.**

**Please note that some Vishay documentation may still make reference to RoHS Directive 2002/95/EC. We confirm that all the products identified as being compliant to Directive 2002/95/EC conform to Directive 2011/65/EU.**