

◆ Tools

Type	Item	Part Number	CL No.	Applicable Contacts
Automatic	Press unit	CM-105	901-0005-4	DF22/DF22A-1416SCF/PCF
	Applicators are used in automatic crimping machines manufactured by Hirose Electric	AP105-DF22-1416	901-4576-7	DF22-1416SCF/PCF
		AP105-DF22A-1416	901-4578-2	DF22A-1416SCF/PCF
	Applicators are used in automatic crimping machines manufactured by other companies	AP109A-DF22-1416	901-4579-5	DF22-1416SCF/PCF
		AP109A-DF22A-1416	901-4580-4	DF22A-1416SCF/PCF
		AP109A-DF22A-1012	901-4582-0	DF22A-1012SCF
Manual	Crimp tools	HT104/DF22-1416	550-0285-0	DF22-1416SC/PC
		HT104/DF22A-1416	550-0286-2	DF22A-1416SC/PC
		HT103/DF22A-1012	550-0288-8	DF22A-1012SC

Note 1: When crimping contact DF22A-1012SCF use a press with 3.5 ton min.

Note 2: AP109A type applicators cannot be used with the CM-105 press.

◆ Contact Extraction

■ Contact extraction tool: Flat-bladed screwdriver, 1.4 mm blade width

■ Intended crimp Contacts: DF22-1416SC(F), DF22A-1416SC(F), DF22A-1012SC(F), DF22-1416PC(F), and DF22A-1416PC(F)

■ Work Method

Housing Cross-Sectional Diagram

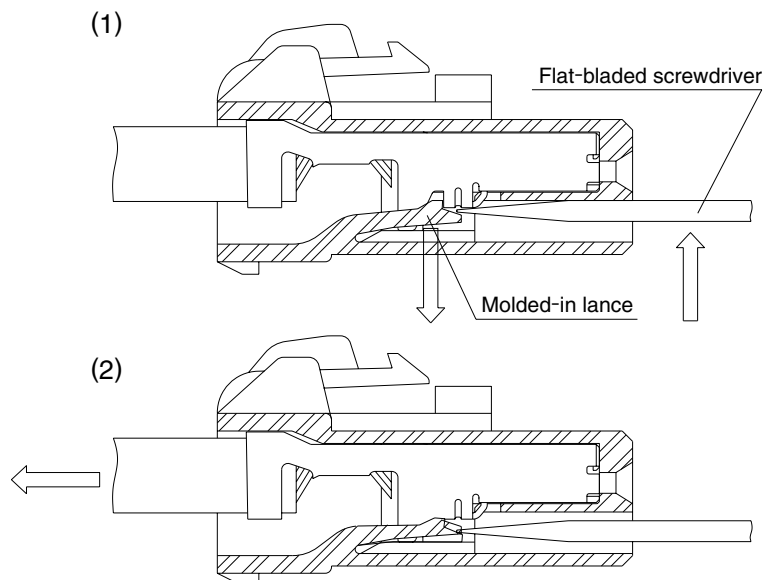

1. Refer to the drawing No. 1. Insert correct size screwdriver in the insulator against the molded-in lance. Deflect the lance as shown.

2. Assure that the lance is deflected to release the contact and pull-out wire with the terminated contact.

◆ Precautions

● Make sure that the lock is fully depressed before un-mating the connectors.

● Use correct size of the wires. Do NOT forcefully twist or deform wires, as this may affect the crimped contact connection.