

1 5/16" (33.3 mm) Low Cost Industrial Single Turn Wirewound, Bushing Mount Type



FEATURES

- Suitable model for all industrial applications
- Center tap available
- Continuous rotation and mechanical stops both standard
- Large electrical angle: $352^\circ \pm 2^\circ$



RoHS
COMPLIANT

ELECTRICAL SPECIFICATIONS		
PARAMETER	MIL-PRF-12934 TEST PROCEDURES APPLY	
	STANDARD	SPECIAL
Total Resistance Tolerance: 50 Ω and Above Below 50 Ω	5 Ω to 20 k Ω $\pm 3\%$ $\pm 5\%$	to 35 k Ω $\pm 1\%$ $\pm 3\%$
Linearity (Independent) Total Resistance 5 Ω to 20 Ω 20 Ω to 200 Ω 200 Ω and Above	STANDARD $\pm 1.0\%$ $\pm 1.0\%$ $\pm 0.5\%$	BEST PRACTICAL $\pm 0.75\%$ $\pm 0.50\%$ $\pm 0.25\%$
Noise	100 Ω ENR	
Power Rating	40 $^\circ\text{C}$ ambient 2.75 W derated to zero at 125 $^\circ\text{C}$	
Electrical Angle Continuous Rotation Stops	352 $^\circ \pm 2^\circ$ 340 $^\circ \pm 5^\circ$	
Insulation Resistance	1000 M Ω minimum at 500 V _{DC}	
Dielectric Strength	1000 V _{RMS} , 60 Hz	
Absolute Minimum Resistance	1.0 % of total resistance or 0.5 Ω whichever is greater	
Minimum Voltage	0.5 % maximum	
Temperature Coefficient of Resistance	Refer to standard resistance element data	

MATERIAL SPECIFICATIONS	
Housing	Molded glass filled thermoplastic
Rear Lid	Glass filled thermoset plastic
Shaft	Stainless steel, non-magnetic
Terminals	Brass, plated for solderability, Non-passivated
Mount Hardware Lockwasher Internal Tooth: Panel Nut:	Steel, nickel plated Brass, nickel plated

ENVIRONMENTAL SPECIFICATIONS	
Vibration	15 Gs thru 2000 Hz
Shock	50 g
Salt Spray	48 h
Rotational Life Shaft Revolutions	500 000
Operating Temperature Range	- 55 $^\circ\text{C}$ to + 125 $^\circ\text{C}$

ORDERING INFORMATION/DESCRIPTION				
132	0	0	20K	B010
MODEL	MECHANICAL OPTIONS	OTHER OPTIONAL FEATURES	OHMIC VALUE	PACKAGING
	0. Continuous 2. Stops	0. Standard (end taps) 1. Center tap (within 5 $^\circ$ of electrical center)		Box of 10 pieces
Other characteristics will be standard as described on this specification sheet. If special characteristics are required such as special linearity tolerance, special resistance tolerance, non-linear functions, etc., please state these on your order.				

SAP PART NUMBERING GUIDELINES				
132	2	1	103	B10
MODEL	MECHANICAL OPTIONS	ELECTRICAL OPTIONS	OHMIC VALUE	PACKAGING
	2: With stops	1: With center tap	103: 10K	Box of 10 pieces



1 5/16" (33.3 mm) Low Cost Industrial Single Turn Vishay Spectrol Wirewound, Bushing Mount Type

DIMENSIONS in inches (millimeters)

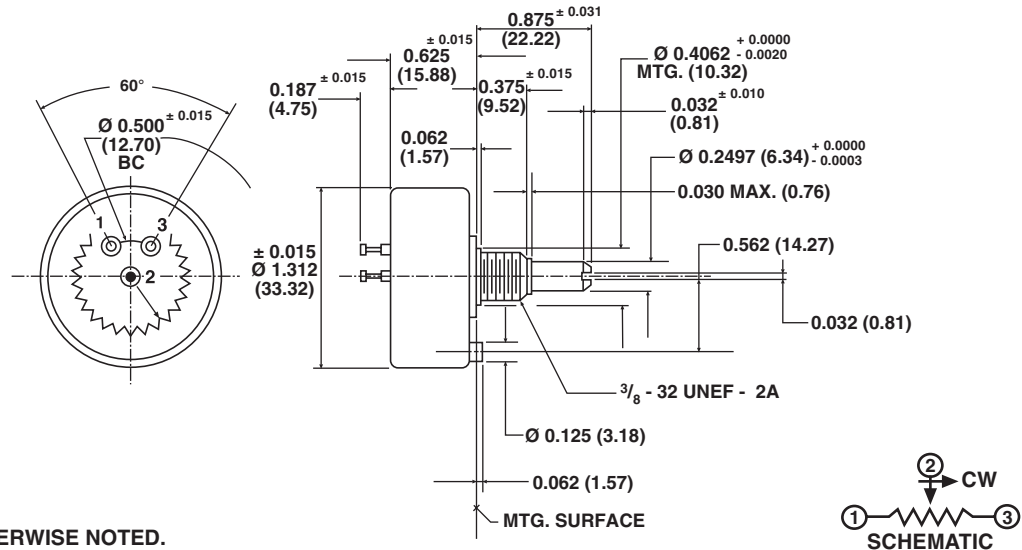

TOLERANCES: UNLESS OTHERWISE NOTED.
DECIMALS ± 0.005 ANGLES ± 2°

MECHANICAL SPECIFICATIONS		
PARAMETER		
Rotation	360° (continuous) or 340° ± 5° (stops)	
Bearing Type	Sleeve	
Torque (Maximums)	STARTING 1.0 oz. - in (72 g - cm)	RUNNING 0.7 oz.- in (50.40 g - cm)
Runouts (Maximums)		
Shaft Runout (TIR)	0.002" (0.05 mm)	
Pilot Dia. Runout (TIR)	0.003" (0.08 mm)	
Lateral Runout (TIR)	0.005" (0.13 mm)	
Shaft End Play	0.008" (0.20 mm)	
Shaft Radial Play	0.003" (0.08 mm)	
Weight	1.0 oz. maximum (28.35 g)	
Stop Strength	8.0 in - lbs (9.21 kg - cm) (stops version only)	

POWER RATING CHART

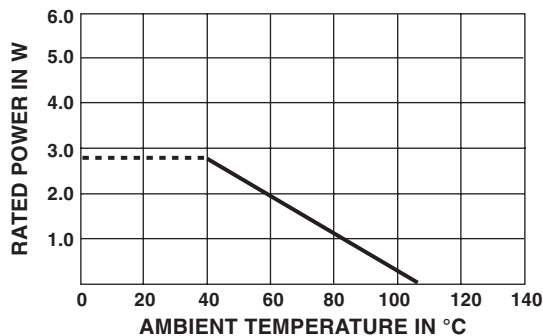

RESISTANCE ELEMENT DATA

RESISTANCE VALUES (Ω)	RESOLUTION (%)	OHMS PER TURN	MAXIMUM CURRENT AT 40 °C AMBIENT (mA)	MAXIMUM VOLTAGE ACROSS COIL (V)	WIRE TEMP. COEF. (ppm/°C)
5	0.419	0.021	742	3.71	800
10	0.327	0.032	524	5.24	800
20	0.280	0.056	371	7.42	800
50	0.290	0.145	234	11.7	20
100	0.251	0.251	166	16.6	20
200	0.212	0.424	122	24.4	20
500	0.161	0.806	74.2	37.1	20
1K	0.150	1.50	52.4	52.4	20
2K	0.132	2.64	37.1	74.2	20
5K	0.107	5.34	23.4	117	20
10K	0.080	7.98	16.6	166	20
20K	0.067	13.4	12.2	244	20
35K	0.057	20.0	8.88	311	20

MARKING	
Unit Identification	Units shall be marked with Vishay Spectrol name, model number, resistance and tolerance, linearity, terminal identification, and data code Applicable test procedures: MIL-R-12934



Disclaimer

ALL PRODUCT, PRODUCT SPECIFICATIONS AND DATA ARE SUBJECT TO CHANGE WITHOUT NOTICE TO IMPROVE RELIABILITY, FUNCTION OR DESIGN OR OTHERWISE.

Vishay Intertechnology, Inc., its affiliates, agents, and employees, and all persons acting on its or their behalf (collectively, "Vishay"), disclaim any and all liability for any errors, inaccuracies or incompleteness contained in any datasheet or in any other disclosure relating to any product.

Vishay makes no warranty, representation or guarantee regarding the suitability of the products for any particular purpose or the continuing production of any product. To the maximum extent permitted by applicable law, Vishay disclaims (i) any and all liability arising out of the application or use of any product, (ii) any and all liability, including without limitation special, consequential or incidental damages, and (iii) any and all implied warranties, including warranties of fitness for particular purpose, non-infringement and merchantability.

Statements regarding the suitability of products for certain types of applications are based on Vishay's knowledge of typical requirements that are often placed on Vishay products in generic applications. Such statements are not binding statements about the suitability of products for a particular application. It is the customer's responsibility to validate that a particular product with the properties described in the product specification is suitable for use in a particular application. Parameters provided in datasheets and/or specifications may vary in different applications and performance may vary over time. All operating parameters, including typical parameters, must be validated for each customer application by the customer's technical experts. Product specifications do not expand or otherwise modify Vishay's terms and conditions of purchase, including but not limited to the warranty expressed therein.

Except as expressly indicated in writing, Vishay products are not designed for use in medical, life-saving, or life-sustaining applications or for any other application in which the failure of the Vishay product could result in personal injury or death. Customers using or selling Vishay products not expressly indicated for use in such applications do so at their own risk and agree to fully indemnify and hold Vishay and its distributors harmless from and against any and all claims, liabilities, expenses and damages arising or resulting in connection with such use or sale, including attorneys fees, even if such claim alleges that Vishay or its distributor was negligent regarding the design or manufacture of the part. Please contact authorized Vishay personnel to obtain written terms and conditions regarding products designed for such applications.

No license, express or implied, by estoppel or otherwise, to any intellectual property rights is granted by this document or by any conduct of Vishay. Product names and markings noted herein may be trademarks of their respective owners.

Material Category Policy

Vishay Intertechnology, Inc. hereby certifies that all its products that are identified as RoHS-Compliant fulfill the definitions and restrictions defined under Directive 2011/65/EU of The European Parliament and of the Council of June 8, 2011 on the restriction of the use of certain hazardous substances in electrical and electronic equipment (EEE) - recast, unless otherwise specified as non-compliant.

Please note that some Vishay documentation may still make reference to RoHS Directive 2002/95/EC. We confirm that all the products identified as being compliant to Directive 2002/95/EC conform to Directive 2011/65/EU.