

AD667–SPECIFICATIONS (@ T_A = +25°C, ±12 V, ±15 V power supplies unless otherwise noted)

Model	AD667J			AD667K			Units
	Min	Typ	Max	Min	Typ	Max	
DIGITAL INPUTS							
Resolution			12			12	Bits
Logic Levels (TTL, Compatible, T _{MIN} –T _{MAX}) ¹							
V _{IH} (Logic “1”)	+2.0		+5.5	+2.0		+5.5	V
V _{IL} (Logic “0”)	0		+0.8	0		+0.8	V
I _{IH} (V _{IH} = 5.5 V)		3	10		3	10	μA
I _{IL} (V _{IL} = 0.8 V)		1	5		1	5	μA
TRANSFER CHARACTERISTICS							
ACCURACY							
Linearity Error @ +25°C		±1/4	±1/2		±1/8	±1/4	LSB
T _A = T _{MIN} to T _{MAX}		±1/2	±3/4		±1/4	±1/2	LSB
Differential Linearity Error @ +25°C		±1/2	±3/4		±1/4	±1/2	LSB
T _A = T _{MIN} to T _{MAX}		Monotonicity Guaranteed			Monotonicity Guaranteed		LSB
Gain Error ²		±0.1	±0.2		±0.1	±0.2	% FSR ³
Unipolar Offset Error ²		±1	±2		±1	±2	LSB
Bipolar Zero ²		±0.05	±0.1		±0.05	±0.1	% of FSR
DRIFT							
Differential Linearity		±2			±2		ppm of FSR/°C
Gain (Full Scale) T _A = 25°C to T _{MIN} or T _{MAX}		±5	±30		±5	±15	ppm of FSR/°C
Unipolar Offset T _A = –25°C to T _{MIN} or T _{MAX}		±1	±3			±3	ppm of FSR/°C
Bipolar Zero T _A = 25°C to T _{MIN} or T _{MAX}		±5	±10			±10	ppm of FSR/°C
CONVERSION SPEED							
Settling Time to ±0.01% of FSR for FSR Change (2 kΩ 500 pF Load) with 10 kΩ Feedback		3	4		3	4	μs
with 5 kΩ Feedback		2	3		2	3	μs
For LSB Change		1			1		μs
Slew Rate	10			10			V/μs
ANALOG OUTPUT							
Ranges ⁴		±2.5, ±5, ±10, +5, +10			±2.5, ±5, ±10, +5, +10		V
Output Current	±5			±5			mA
Output Impedance (DC)		0.05			0.05		Ω
Short Circuit Current			40			40	mA
REFERENCE OUTPUT							
External Current	9.90	10.00	10.10	9.90	10.00	10.10	V
	0.1	1.0		0.1	1.0		mA
POWER SUPPLY SENSITIVITY							
V _{CC} = +11.4 V to +16.5 V dc		5	10		5	10	ppm of FS/%
V _{EE} = –11.4 V to –16.5 V dc		5	10		5	10	ppm of FS/%
POWER SUPPLY REQUIREMENTS							
Rated Voltages		±12, ±15			±12, ±15		V
Range ⁴	±11.4		±16.5	±11.4		±16.5	V
Supply Current							
+11.4 V to +16.5 V dc		8	12		8	12	mA
–11.4 V to –16.5 V dc		20	25		20	25	mA
TEMPERATURE RANGE							
Specification	0		+70	0		+70	°C
Storage	–65		+125	–65		+125	°C

NOTES

¹The digital input specifications are 100% tested at +25°C, and guaranteed but not tested over the full temperature range.

²Adjustable to zero.

³FSR means “Full-Scale Range” and is 20 V for ±10 V range and 10 V for the ±5 V range.

⁴A minimum power supply of ±12.5 V is required for a ±10 V full-scale output and ±11.4 V is required for all other voltage ranges.

Specifications subject to change without notice.

Specifications shown in **boldface** are tested on all production units at final electrical test. Results from those tests are used to calculate outgoing quality levels. All min and max specifications are guaranteed, although only those shown in boldface are tested on all production units.

TIMING SPECIFICATIONS

(All Models, T_A = +25°C, V_{CC} = +12 V or +15 V, V_{EE} = –12 V or –15 V)

Symbol	Parameter	Min	Typ	Max	
t _{DC}	Data Valid to End of \overline{CS}	50	–	–	ns
t _{AC}	Address Valid to End of \overline{CS}	100	–	–	ns
t _{CP}	\overline{CS} Pulse Width	100	–	–	ns
t _{DH}	Data Hold Time	0	–	–	ns
t _{SETT}	Output Voltage Settling Time	–	2	4	μs

ABSOLUTE MAXIMUM RATINGS

V _{CC} to Power Ground	0 V to +18 V
V _{EE} to Power Ground	0 V to –18 V
Digital Inputs (Pins 11–15, 17–28)	
to Power Ground	–1.0 V to +7.0 V
Ref In to Reference Ground	±12 V
Bipolar Offset to Reference Ground	±12 V
10 V Span R to Reference Ground	±12 V
20 V Span R to Reference Ground	±24 V
Ref Out, V _{OUT} (Pins 6, 9) .. Indefinite Short to Power Ground	
..... Momentary Short to V _{CC}	
Power Dissipation	1000 mW

Model	AD667A			AD667B			AD667S			Units
	Min	Typ	Max	Min	Typ	Max	Min	Typ	Max	
DIGITAL INPUTS										
Resolution			12			12			12	Bits
Logic Levels (TTL, Compatible, T_{MIN} - T_{MAX}) ¹										
V_{IH} (Logic "1")	+2.0		+5.5	+2.0		+5.5	+2.0		+5.5	V
V_{IL} (Logic "0")	0		+0.8	0		+0.8	0		+0.7	V
I_{IH} ($V_{IH} = 5.5$ V)		3	10		3	10		3	10	μ A
I_{IL} ($V_{IL} = 0.8$ V)		1	5		1	5		1	5	μ A
TRANSFER CHARACTERISTICS										
ACCURACY										
Linearity Error @ +25°C		$\pm 1/4$	$\pm 1/2$		$\pm 1/8$	$\pm 1/4$		$\pm 1/8$	$\pm 1/2$	LSB
$T_A = T_{MIN}$ to T_{MAX}		$\pm 1/2$	$\pm 3/4$		$\pm 1/4$	$\pm 1/2$		$\pm 1/8$	$\pm 3/4$	LSB
Differential Linearity Error @ +25°C		$\pm 1/2$	$\pm 3/4$		$\pm 1/4$	$\pm 1/2$		$\pm 1/4$	$\pm 3/4$	LSB
$T_A = T_{MIN}$ to T_{MAX}		Monotonicity Guaranteed		Monotonicity Guaranteed		Monotonicity Guaranteed		Monotonicity Guaranteed		LSB
Gain Error ²		± 0.1	± 0.2		± 0.1	± 0.2		± 0.1	± 0.2	% FSR ³
Unipolar Offset Error ²		± 1	± 2		± 1	± 2		± 1	± 2	LSB
Bipolar Zero ²		± 0.05	± 0.1		± 0.05	± 0.1		± 0.05	± 0.1	% of FSR
DRIFT										
Differential Linearity		± 2			± 2			± 2		ppm of FSR/°C
Gain (Full Scale) $T_A = 25^\circ\text{C}$ to T_{MIN} or T_{MAX}		± 5	± 30		± 5	± 15		± 15	± 30	ppm of FSR/°C
Unipolar Offset $T_A = 25^\circ\text{C}$ to T_{MIN} or T_{MAX}		± 1	± 3			± 3			± 3	ppm of FSR/°C
Bipolar Zero $T_A = 25^\circ\text{C}$ to T_{MIN} or T_{MAX}		± 5	± 10			± 10			± 10	ppm of FSR/°C
CONVERSION SPEED										
Settling Time to $\pm 0.01\%$ of FSR for FSR Change (2 k Ω /500 pF Load)										
with 10 k Ω Feedback		3	4		3	4		3	4	μ s
with 5 k Ω Feedback		2	3		2	3		2	3	μ s
For LSB Change		1			1			1		μ s
Slew Rate	10			10			10			V/ μ s
ANALOG OUTPUT										
Ranges ⁴		$\pm 2.5, \pm 5, \pm 10,$ $+5, +10$			$\pm 2.5, \pm 5, \pm 10,$ $+5, +10$			$\pm 2.5, \pm 5, \pm 10,$ $+5, +10$		V
Output Current	± 5			± 5			± 5			mA
Output Impedance (DC)		0.05			0.05			0.05		Ω

PIN CONNECTIONS

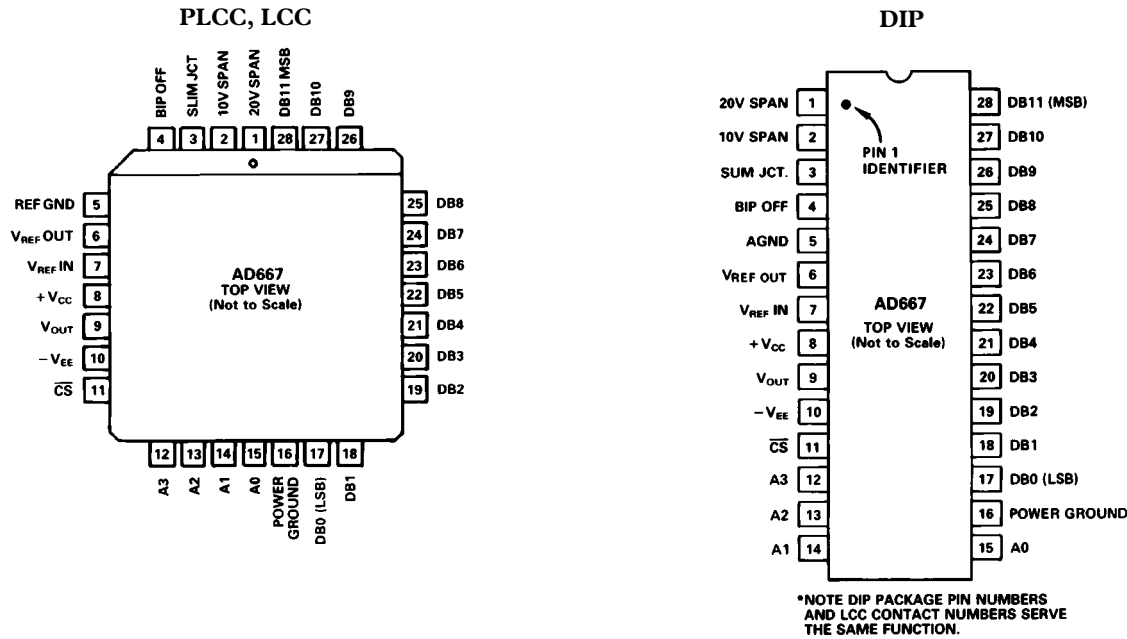

ORDERING GUIDE

Model ¹	Temperature Range—°C	Linearity Error Max @ +25°C	Gain TC Max ppm/°C	Package Option ²
AD667JN	0 to +70	±1/2 LSB	30	Plastic DIP (N-28)
AD667JP	0 to +70	±1/2 LSB	30	PLCC (P-28A)
AD667KN	0 to +70	±1/4 LSB	15	Plastic DIP (N-28)
AD667KP	0 to +70	±1/4 LSB	15	PLCC (P-28A)
AD667AD	25 to +85	±1/2 LSB	30	Ceramic DIP (D-28)
AD667BD	-25 to +85	±1/4 LSB	15	Ceramic DIP (D-28)
AD667SD	-55 to +125	±1/2 LSB	30	Ceramic DIP (D-28)
AD667SE	-55 to +125	±1/2 LSB	30	LCC (E-28A)
AD667/883B	-55 to +125	*	*	*

NOTES

*Refer to AD667/883B military data sheet.

¹For details on grade and package offerings screened in accordance with MIL-STD-883, refer to the Analog Devices Military Products Databook or current AD667/883B data sheet.

²D = Ceramic DIP; E = Leadless Ceramic Chip Carrier; N = Plastic DIP; P = Plastic Leaded Chip.

THE AD667 OFFERS TRUE 12-BIT PERFORMANCE OVER THE FULL TEMPERATURE RANGE

LINEARITY ERROR: Analog Devices defines linearity error as the maximum deviation of the actual, adjusted DAC output

from the ideal analog output (a straight line drawn from 0 to FS - 1 LSB) for any bit combination. The AD667 is laser trimmed to 1/4 LSB (0.006% of FS) maximum error at +25°C for the K and B versions and 1/2 LSB for the J, A and S versions.

MONOTONICITY: A DAC is said to be monotonic if the output either increases or remains constant for increasing digital inputs such that the output will always be a nondecreasing function of input. All versions of the AD667 are monotonic over their full operating temperature range.

DIFFERENTIAL NONLINEARITY: Monotonic behavior requires that the differential linearity error be less than 1 LSB both at +25°C and over the temperature range of interest. Differential nonlinearity is the measure of the variation in analog value, normalized to full scale, associated with a 1 LSB change in digital input code. For example, for a 10 volt full-scale output, a change of 1 LSB in digital input code should result in a 2.44 mV change in the analog output (1 LSB = 10 V × 1/4096 = 2.44 mV). If in actual use, however, a 1 LSB change in the input code results in a change of only 0.61 mV (1/4 LSB) in analog output, the differential linearity error would be -1.83 mV, or -3/4 LSB. The AD667K and B grades have a max differential linearity error of 1/2 LSB, which specifies that every step will be at least 1/2 LSB and at most 1 1/2 LSB.

Table I. Output Voltage Range Connections

Output Range	Digital Input Codes	Connect Pin 9 to	Connect Pin 1 to	Connect Pin 2 to	Connect Pin 4 to
±10 V	Offset Binary	1	9	NC	6 (Through 50 Ω Fixed or 100 Ω Trim Resistor)
±5 V	Offset Binary	1 and 2	2 and 9	1 and 9	6 (Through 50 Ω Fixed or 100 Ω Trim Resistor)
±2.5 V	Offset Binary	2	3	9	6 (Through 50 Ω Fixed or 100 Ω Trim Resistor)
0 V to +10 V	Straight Binary	1 and 2	2 and 9	1 and 9	5 (or Optional Trim—See Figure 2)
0 V to +5 V	Straight Binary	2	3	9	5 (or Optional Trim—See Figure 2)

ANALOG CIRCUIT CONNECTIONS

Internal scaling resistors provided in the AD667 may be connected to produce bipolar output voltage ranges of ± 10 , ± 5 or ± 2.5 V or unipolar output voltage ranges of 0 V to +5 V or 0 V to +10 V.

Gain and offset drift are minimized in the AD667 because of the thermal tracking of the scaling resistors with other device components. Connections for various output voltage ranges are shown in Table I.

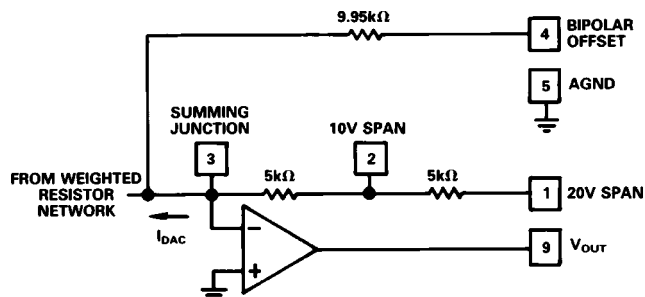

Figure 1. Output Amplifier Voltage Range Scaling Circuit

UNIPOLAR CONFIGURATION (Figure 2)

This configuration will provide a unipolar 0 volt to +10 volt output range. In this mode, the bipolar offset terminal, Pin 4, should be grounded if not used for trimming.

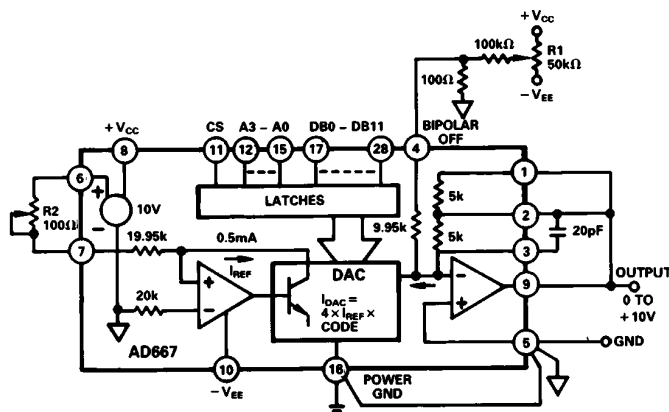

Figure 2. 0 V to +10 V Unipolar Voltage Output

STEP I . . . ZERO ADJUST

Turn all bits OFF and adjust zero trimmer R1, until the output reads 0.000 volts (1 LSB = 2.44 mV). In most cases this trim is not needed, and Pin 4 should be connected to Pin 5.

STEP II . . . GAIN ADJUST

Turn all bits ON and adjust 100 Ω gain trimmer R2, until the output is 9.9976 volts. (Full scale is adjusted to 1 LSB less than nominal full scale of 10.000 volts.)

BIPOLAR CONFIGURATION (Figure 3)

This configuration will provide a bipolar output voltage from -5.000 to +4.9976 volts, with positive full scale occurring with all bits ON (all 1s).

STEP I . . . OFFSET ADJUST

Turn OFF all bits. Adjust 100 Ω trimmer R1 to give -5.000 volts output.

STEP II . . . GAIN ADJUST

Turn ON all bits. Adjust 100 Ω gain trimmer R2 to give a reading of +4.9976 volts.

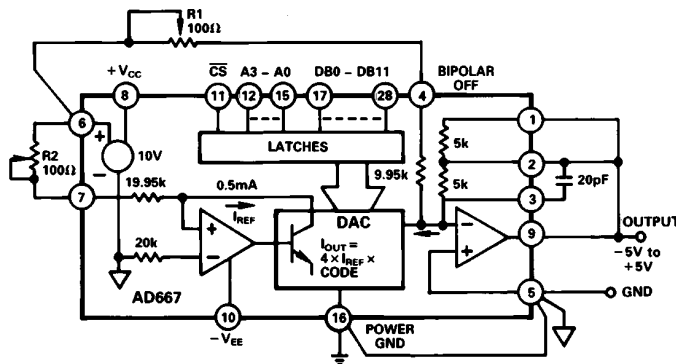

Figure 3. ± 5 V Bipolar Voltage Output

INTERNAL/EXTERNAL REFERENCE USE

The AD667 has an internal low noise buried Zener diode reference which is trimmed for absolute accuracy and temperature coefficient. This reference is buffered and optimized for use in a high speed DAC and will give long-term stability equal or superior to the best discrete Zener reference diodes. The performance of the AD667 is specified with the internal reference driving the DAC since all trimming and testing (especially for full-scale error and bipolar offset) is done in this configuration.

The internal reference has sufficient buffering to drive external circuitry in addition to the reference currents required for the DAC (typically 0.5 mA to Ref In and 1.0 mA to Bipolar Off-

AD667

Small resistors may be added to the feedback resistors in order to accomplish small modifications in the scaling. For example, if a 10.24 V full scale is desired, a 140 Ω 1% low TC metal-film resistor can be added in series with the internal (nominal) 5k feedback resistor, and the gain trim potentiometer (between Pins 6 and 7) should be increased to 200 Ω . In the bipolar mode, increase the value of the bipolar offset trim potentiometer also to 200 Ω .

GROUNDING RULES

The AD667 brings out separate analog and power grounds to allow optimum connections for low noise and high speed performance. These grounds should be tied together at one point, usually the device power ground. The separate ground returns are provided to minimize current flow in low level signal paths.

The analog ground at Pin 5 is the ground point for the output amplifier and is thus the “high quality” ground for the AD667; it should be connected directly to the analog reference point of the system. The power ground at Pin 16 can be connected to the most convenient ground point; analog power return is preferred. If power ground contains high frequency noise beyond 200 mV, this noise may feed through the converter, thus some caution will be required in applying these grounds.

It is also important to apply decoupling capacitors properly on the power supplies for the AD667 and the output amplifier. The correct method for decoupling is to connect a capacitor from each power supply pin of the AD667 to the analog ground pin of the AD667. Any load driven by the output amplifier should also be referred to the analog ground pin.

OPTIMIZING SETTLING TIME

The dynamic performance of the AD667's output amplifier can be optimized by adding a small (20 pF) capacitor across the feedback resistor. Figure 4 shows the improvement in both large-signal and small-signal settling for the 10 V range. In Figure 4a, the top trace shows the data inputs (DB11–DB0 tied together), the second trace shows the CS pulse (A3–A0 tied low), and the lower two traces show the analog outputs for $C_F = 0$ pF and 20 pF respectively.

Figures 4b and 4c show the settling time for the transition from all bits on to all bits off. Note that the settling time to $\pm 1/2$ LSB for the 10 V step is improved from 2.4 microseconds to 1.6 microseconds by the addition of the 20 pF capacitor.

Figures 4d and 4e show the settling time for the transition from all bits off to all bits on. The improvement in settling time gained by adding $C_C = 20$ pF is similar.

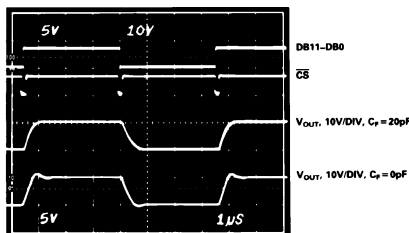
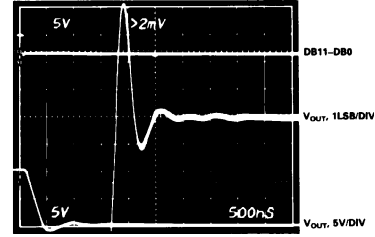

a. Large Scale Settling

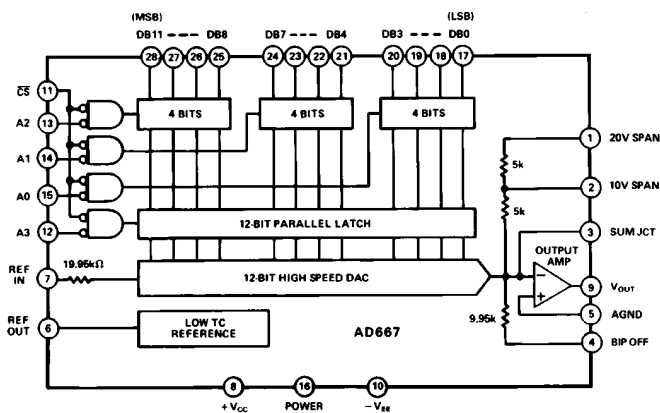

Figure 5. AD667 Block Diagram

It is permissible to enable more than one of the latches simultaneously. If a first rank latch is enabled coincident with the second rank latch, the data will reach the second rank correctly if the "WRITE CYCLE #1" timing specifications are met.

Table II. AD667 Truth Table

CS	A3	A2	A1	A0	Operation
1	X	X	X	X	No Operation
X	1	1	1	1	No Operation
0	1	1	1	0	Enable 4 LSBs of First Rank
0	1	1	0	1	Enable 4 Middle Bits of First Rank
0	1	0	1	1	Enable 4 MSBs of First Rank
0	0	1	1	1	Loads Second Rank from First Rank
0	0	0	0	0	All Latches Transparent

"X" = Don't Care.

INPUT CODING

The AD667 uses positive-true binary input coding. Logic "1" is represented by an input voltage greater than 2.0 V and Logic "0" is defined as an input voltage less than 0.8 V.

Unipolar coding is straight binary, where all zeroes (000_H) on the data inputs yields a zero analog output and all ones (FFF_H) yields an analog output 1 LSB below full scale.

Bipolar coding is offset binary, where an input code of 000_H yields a minus full-scale output, an input of FFF_H yields an output 1 LSB below positive full scale, and zero occurs for an input code with only the MSB on (800_H).

The AD667 can be used with twos complement input coding if an inverter is used on the MSB (DB11).

DIGITAL INPUT CONSIDERATIONS

The threshold of the digital input circuitry is set at 1.4 volts and does not vary with supply voltage. The input lines can thus interface with any type of 5 volt logic. The configuration of the input circuit is shown in Figure 6.

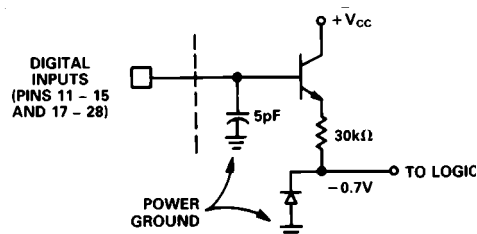

Figure 6. Equivalent Digital Input Circuit

The AD667 data and control inputs will float to a Logic 0 if left open. It is recommended that any unused inputs be connected to power ground to improve noise immunity.

Fanout for the AD667 is 100 when used with a standard low power Schottky gate output device.

8-BIT MICROPROCESSOR INTERFACE

The AD667 interfaces easily to 8-bit microprocessor systems of all types. The control logic makes possible the use of right- or left-justified data formats.

Whenever a 12-bit DAC is loaded from an 8-bit bus, two bytes are required. If the program considers the data to be a 12-bit binary fraction (between 0 and 4095/4096), the data is left-justified, with the eight most significant bits in one byte and the remaining bits in the upper half of another byte. Right-justified data calls for the eight least significant bits to occupy one byte, with the 4 most significant bits residing in the lower half of another byte, simplifying integer arithmetic.

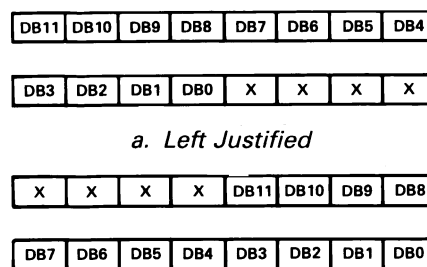

b. Right Justified

Figure 7. 12-Bit Data Formats for 8-Bit Systems

Figure 8 shows an addressing scheme for use with an AD667 set up for left-justified data in an 8-bit system. The base address is decoded from the high-order address bits and the resultant active-low signal is applied to \overline{CS} . The two LSBs of the address bus are connected as shown to the AD667 address inputs. The latches now reside in two consecutive locations, with location X01 loading the four LSBs and location X10 loading the eight MSBs and updating the output.

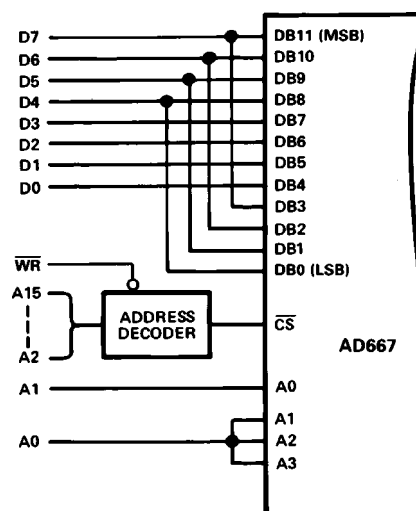

Figure 8. Left-Justified 8-Bit Bus Interface

AD667

Right-justified data can be similarly accommodated. The overlapping of data lines is reversed, and the address connections are slightly different. The AD667 still occupies two adjacent locations in the processor's memory map. In the circuit of Figure 9, location X01 loads the 8 LSBs and location X10 loads the 4 MSBs and updates the output.

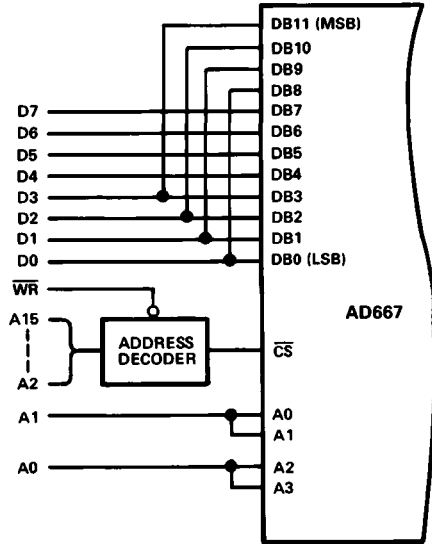

Figure 9. Right-Justified 8-Bit Bus Interface

USING THE AD667 WITH 12- AND 16-BIT BUSES

The AD667 is easily interfaced to 12- and 16-bit data buses. In this operation, all four address lines (A0 through A3) are tied

low, and the latch is enabled by \overline{CS} going low. The AD667 thus occupies a single memory location.

This configuration uses the first and second rank registers simultaneously. The \overline{CS} input can be driven from an active-low decoded address. It should be noted that any data bus activity during the period when \overline{CS} is low will cause activity at the AD667 output. If data is not guaranteed stable during this period, the second rank register can be used to provide double buffering.

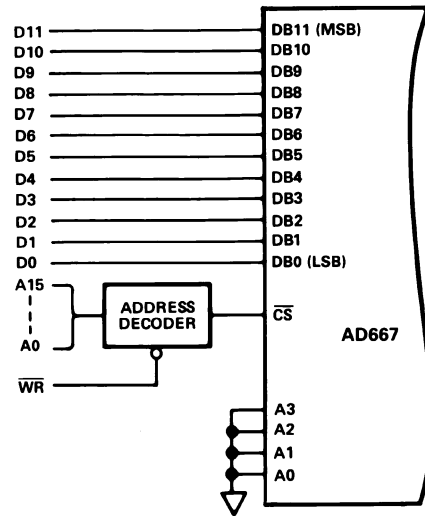
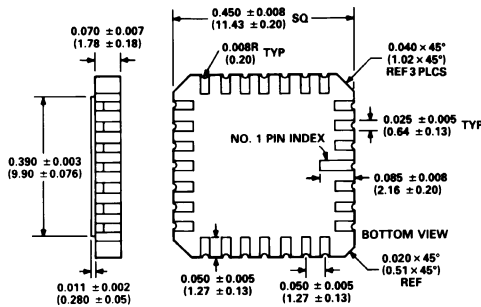

Figure 10. Connections for 12- and 16-Bit Bus Interface

OUTLINE DIMENSIONS

Dimensions shown in inches and (mm).

28-Contact LCC (E)



28-Terminal Plastic Leaded Chip Carrier (P)

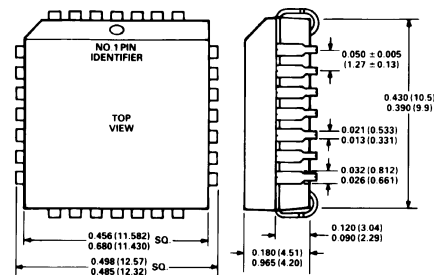

28-Pin Plastic DIP (N)

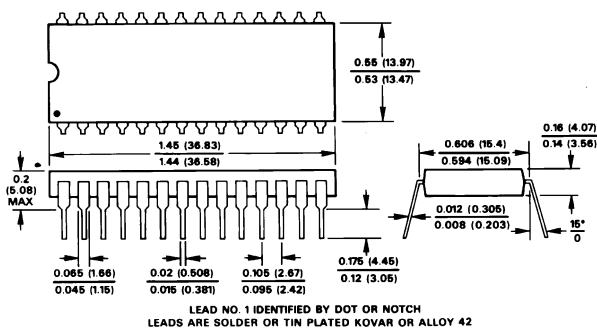

28-Pin Ceramic DIP (D)

