

## 1. Dimension

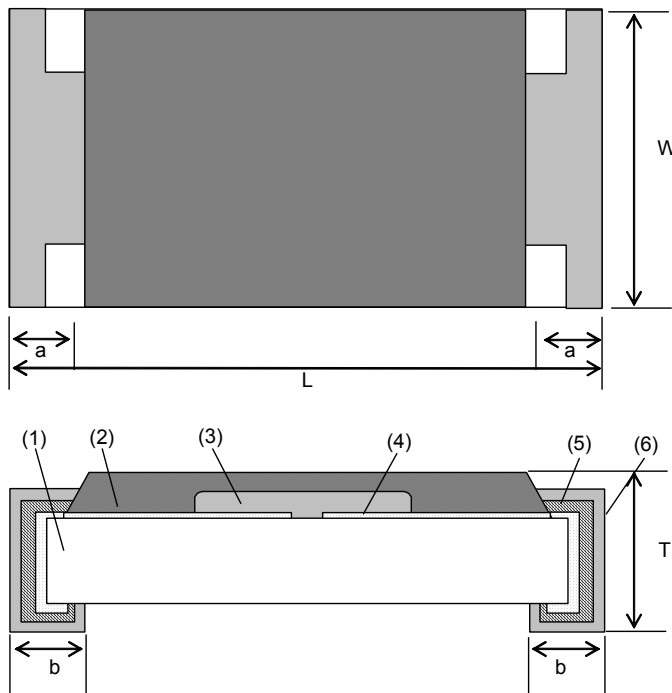

- (1) Substrate : Alumina
- (2) Protective Coating : Resin
- (3) ESD Absorbent Material
- (4) Gap Electrode
- (5) Ni Termination(Plating)
- (6) Sn Termination(Plating)

	L	W	T	a	b
Dimension (mm)	1.00±0.10	0.50±0.05	0.38±0.05	0.20±0.10	0.25±0.10

## 2. Ratings

Capacitance value	0.05 ± 0.05 pF(25degC,1MHz,1Vrms)
Rated voltage	15V max.
Category temperature range	-55deg.C to 125deg.C

Subject	ESD Suppressor	No.	151-ZA-EEG2-00B
Part No.	<b>EZAEG2A</b>	PAGE	9-2

3. Explanation of part number

1 2 3 4 5 6 7 8 9 10 11  
E Z A E G 2 A 5 0 A X

Product Code  
: ESD Suppressor

Size

Rated  
voltage

Peak  
voltage

Design  
specification

Packaging  
configuration

	Size		Rated voltage		Peak voltage		Design specification		Packaging
2	0402	A	15V	50	500V	A	standard	X	Paper taping

4. Circuit configuration

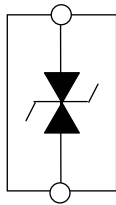

5. Performance specifications

5.1. Test Condition

Ambient temperature : 25 deg.C ± 2 deg.C ,Relative humidity : 40 % to 55 % ,

Atmospheric pressure:86 kPa to 106 kPa

As far as there shall not be designation especially, the following tests and measurement shall be operated under the following conditions ;

Ambient temperature : 15 deg.C to 35 deg.C, Relative humidity : 25 % to 85 %

Subject	ESD Suppressor	No. 151-ZA-EEG2-00B
Part No.	<b>EZAEG2A</b>	PAGE 9-3

### 5.2. Electrical performance

Characteristics	Specifications	Test Methods
5.2.1 Capacitance	0.05 ± 0.05 pF max.	Capacitance value shall be measured at the conditions specified below. Frequency : 1MHz±10% Voltage : 1Vrms±0.2Vrms Temperature : 25degC±2degC
5.2.2. Clamping Voltage	100V max.	Clamping voltage value shall be measured at 30ns after initiation of pulse and measured at the condition specified below. ESD test condition : IEC61000-4-2,8kV contact discharge
5.2.3. Peak Voltage	500V max.	Peak voltage value shall be measured at the condition specified below. ESD test condition : IEC61000-4-2,8kV contact discharge
5.2.4. Leakage Current	1 micro A max.	Leakage current value shall be measured at DC15V.

### 5.3. Environmental performance

Characteristics	Specifications	Test Methods															
5.3.1. Rapid change of temperature	Leakage current :10 micro A max. and no evidence of mechanical damage	Specimens shall be tested for 100 cycles continuously in accordance with the following duty cycle. Measurement shall be done in 48 hours± 4 hours at "standard conditions" after the test. <table border="1" data-bbox="858 1263 1414 1451"> <thead> <tr> <th>Step</th> <th>Temperature</th> <th>Time</th> </tr> </thead> <tbody> <tr> <td>1</td> <td>-55 ± 2 deg.C</td> <td>30min ± 5 min</td> </tr> <tr> <td>2</td> <td>+25 ± 2 deg.C</td> <td>3min max.</td> </tr> <tr> <td>3</td> <td>+125 ± 2 deg.C</td> <td>30min ± 5 min</td> </tr> <tr> <td>4</td> <td>+25 ± 2 deg.C</td> <td>3min max.</td> </tr> </tbody> </table>	Step	Temperature	Time	1	-55 ± 2 deg.C	30min ± 5 min	2	+25 ± 2 deg.C	3min max.	3	+125 ± 2 deg.C	30min ± 5 min	4	+25 ± 2 deg.C	3min max.
Step	Temperature	Time															
1	-55 ± 2 deg.C	30min ± 5 min															
2	+25 ± 2 deg.C	3min max.															
3	+125 ± 2 deg.C	30min ± 5 min															
4	+25 ± 2 deg.C	3min max.															
5.3.2. Humidity	Leakage current :10 micro A max. and no evidence of mechanical damage	Specimens shall be tested for 1000 hours +48/-0 hours in a humidity test chamber controlled at 40degC ± 2 deg.C and 90 % to 95 % relative humidity. Measurement shall be done in 48 hours ±4 hours at "standard conditions" after the test.															
5.3.3. Load Life in humidity	Leakage current :10 micro A max. and no evidence of mechanical damage	Specimens shall be operated at rated voltage for 1000 hours +24/-0 hours in a humidity test chamber controlled at 40degC ± 2degC and 90 % to 95 % relative humidity. Measurement shall be done in 48 hours ±4 hours at "standard conditions" after the test.															
5.3.4. Endurance	Leakage current :10 micro A max. and no evidence of mechanical damage	Specimens shall be operated at rated voltage for 1000 hours +48/-0 hours at 85degC ± 2degC ambient. Measurement shall be done in 48 hours ±4 hours at "standard conditions" after the test.															

Subject	ESD Suppressor	No. 151-ZA-EEG2-00B
Part No.	<b>EZAEG2A</b>	PAGE 9-4

5.3.5. Resistance to soldering heat	Leakage current :10 micro A max. and no evidence of mechanical damage	Specimens shall be immersed in 260 deg.C $\pm$ 5 deg.C solder bath for 5 seconds $\pm$ 1 second after 150 deg.C $\pm$ 5 deg.C pre-heat for 1 minute. Measurement shall be done in 48 hours $\pm$ 4 hours at "standard conditions" after the test.
5.3.6. Solvent resistance	No deterioration of protective coatings.	The specimen shall be immersed in a bath of isopropyl alcohol completely for 5 minutes with ultrasonic.

#### 5.4. Mechanical performance

Characteristics	Specifications	Test Methods
5.4.1. Bending strength	Leakage current :10 micro A max. and no evidence of mechanical damage	Specimens shall be soldered to testing board. The substrate shall be supported at two points 45 mm from its center with mounting surface, and the middle part of its board shall be pressed at rate of 1.0 mm per second until the deflection becomes 3 mm and then the pressure shall be maintained for 30 seconds. <u>Testing board:</u> shall be glass-fabric based epoxy resin with 100 mm in length, 40 mm in width and 1.6 mm in thickness. <u>Pressing rod:</u> shall be a metal rod with 30 mm in thickness and 20 mm in width having a cylindrical end with radius R of 230 mm.
5.4.2. Solderability	95 % coverage min.	Specimens shall be dipped in the melted solder bath at 235 $\pm$ 5 degC for 2 s $\pm$ 1 s. Flux shall be removed from the surface of termination with clean organic solvent.

## 6. Precautions for mounting

## 6.1. Recommendable land pattern

Recommendable land pattern is shown in the figure below.

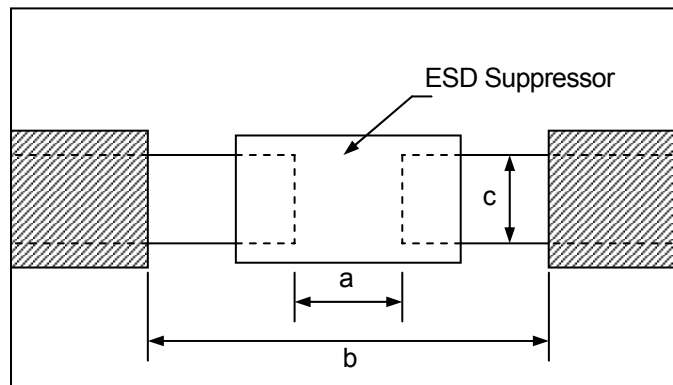

	Dimension(mm)		
	a	b	c
0402size	0.5 to 0.6	1.4 to 1.6	0.4 to 0.6

Subject	ESD Suppressor	No. 151-ZA-EEG2-00B
Part No.	<b>EZAEG2A</b>	PAGE 9-6

## 7. Notice for use

### Notice for use

- (1) This specification shows the quality and performance of the product in a unit component. Before adoption, be sure to evaluate and verify the product mounted on your circuit board.
- (2) We take no responsibility for troubles caused by the product usage that is not specified in this catalog. Be sure to exchange the delivery specification with us.
- (3) Use fail-safe design and ensure safety by carrying out the following items in cases where it is forecast that the failure of the product gives serious damage to something important like human life, for instant in traffic transportation equipment (trains, cars, traffic signal equipment, etc.), medical equipment, aerospace equipment, electric heating appliances, combustion and gas equipment, rotating equipment, disaster and crime preventive equipment.
  - \* Ensure safety as the system by setting protective circuits and protective equipment.
  - \* Ensure safety as the system by setting such redundant circuits as do not cause danger by a single failure.
- (4) When a dogma shall be occurred about safety for this product, be sure to inform us rapidly, operate your technical examination.
- (5) The product is designed to use in general standard applications of general electric equipment (AV products, household electric appliances, office equipment, information and communication equipment, etc.); hence, it do not take the use under the following special environments into consideration. Accordingly, the use in the following special environments, and such environmental conditions may affect the performance of the product; prior to use, verify the performance, reliability, etc. thoroughly.
  - 1) Use in liquids such as water, oil, chemical, and organic solvent.
  - 2) Use under direct sunlight, in outdoor or in dusty atmospheres.
  - 3) Use in places full of corrosive gases such as sea breeze, Cl<sub>2</sub>, H<sub>2</sub>S, NH<sub>3</sub>, SO<sub>2</sub>, and NO<sub>x</sub>.
  - 4) Where the product is close to a heating component, and where an inflammable such as a polyvinyl chloride wire is arranged close to the product.
  - 5) Where the ESD Suppressor is sealed or coated with resin, etc.
  - 6) Where water or a water-soluble detergent is used in cleaning free soldering and in flux cleaning after soldering (Pay particular attention to soluble flux.)
  - 7) Use in such a place where the product is wetted owing to dew condensation
- (6) If large energy surge (especially, larger energy than ESD) is expected to be applied, carry out evaluation and confirmation test with ESD Suppressors actually mounted on your own board. When the load of more than rated power is applied under the load condition at steady state, it may impair performance and/or reliability of ESD Suppressor. Never exceed the rated power. When the product shall be used under special condition, be sure to ask us in advance.
- (7) Halogen type (Chlorine type, Bromine type, etc.) or other high-activity flux is not recommended as the residue may affect performance or reliability of ESD Suppressor.
- (8) When soldering with soldering iron, never touch the body of the ESD Suppressor with a tip of the soldering iron. When using a soldering iron with a tip at high temperature, solder for a time as short as possible. (3 s or less up to 350 deg.C)
- (9) Avoid physical shock to the ESD Suppressor and nipping of the ESD Suppressor with hard tool (a pair of pliers or tweezers) as it may damage protective film or the body of ESD Suppressor and may affect ESD Suppressor's performance.
- (10) Avoid immersion of ESD Suppressor in solvent for long time. Use solvent after the effect of immersion is confirmed.

Subject	ESD Suppressor	No. 151-ZA-EEG2-00B
Part No.	<b>EZAEG2A</b>	PAGE 9-7

#### 8.Storage Method

If the product is stored in the following environments and conditions, the performance and solderability may be badly affected, avoid the storage in the following environments.

- (1) Storage in places full of corrosive gases such as sea breeze, Cl<sub>2</sub>, H<sub>2</sub>S, NH<sub>3</sub>, SO<sub>2</sub>, and NO<sub>x</sub>.
- (2) Storage in places exposed to direct sunlight.
- (3) Storage in places outside the temperature range of 5degC to 35deg.C and humidity range of 45 %RH to 85 %RH.
- (4) The period of guarantee for performance such as solderability is 1 year after our delivery; and this condition applies only to the case where the storage method specified in item 3) has been followed.

#### 9.Laws and Regulations

- (1) This product has not been manufactured with any ozone-depleting chemical controlled under the Montreal Protocol.
- (2) All materials used in this part are registered material under the Law Concerning the Examination and Regulation of Manufactures, etc. of Chemical substances.
- (3) All the materials used in this part contain no brominated materials of PBBO<sub>s</sub> or PBB<sub>s</sub> as the flame-retardant.
- (4) If you need the notice by letter of "A preliminary judgement on the laws of Japan foreign exchange and foreign trade control", be sure to let us know.

#### 10.Production Site

Country: Japan

Plant: Panasonic Electronic Devices Fukui Co., Ltd.

11. Taped and Reel Package

11.1. Physical Dimensions

Structure and dimensions of reel shall be as shown in the figure below

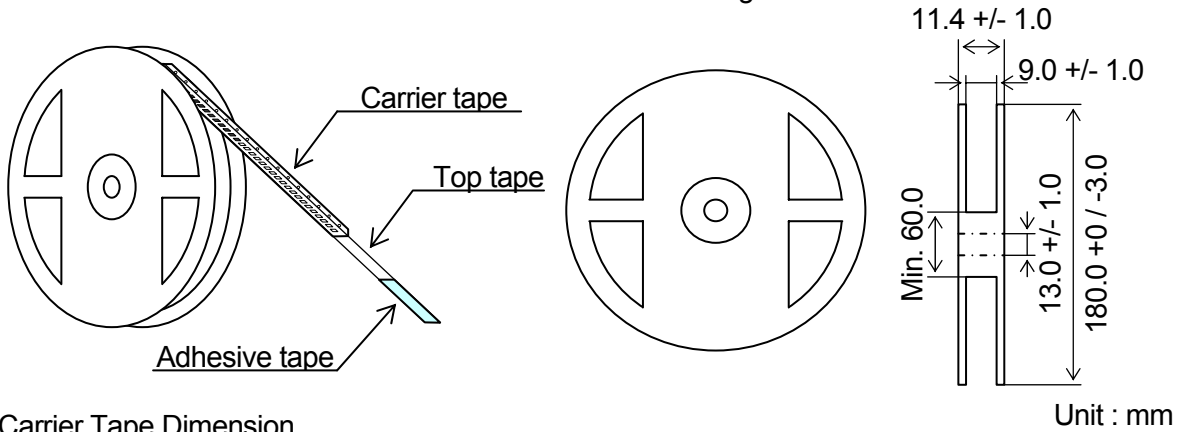

11.2. Carrier Tape Dimension

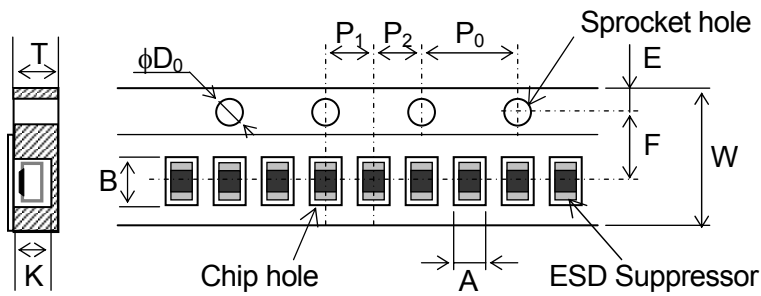

	A	B	W	F	E
Dimension(mm)	0.70±0.05	1.20±0.05	8.00±0.20	3.50±0.05	1.75±0.10

	P <sub>1</sub>	P <sub>2</sub>	P <sub>0</sub>	φD <sub>0</sub>	K	T
Dimension (mm)	2.00±0.10	2.00±0.05	4.00±0.10	1.50 <sup>+0.10</sup> <sub>-0</sub>	0.43±0.05	0.60±0.05



Subject	ESD Suppressor	No. 151-ZA-EEG2-00B
Part No.	<b>EZAEG2A</b>	PAGE 9-9

### 11.3. Specifications

#### 11.3.1. Taping

##### (1) Minimum Bending Radius

When carrier tape shall be bent by minimum bending radius (15mm), no deflection of chip and no break of carrier tape. However minimum bending radius shall be tested for 1 time.

##### (2) Resistance to climate of top tape

When it shall be exposed at 60 degC, 90 %RH to 95 %RH for 120 h, no exfoliation of top tape.

##### (3) When the test shall be operated with the below conditions, peel strength should be 0.049 N to 0.49 N. Tapes should not have flash and tear after peeling.

<Test Method>

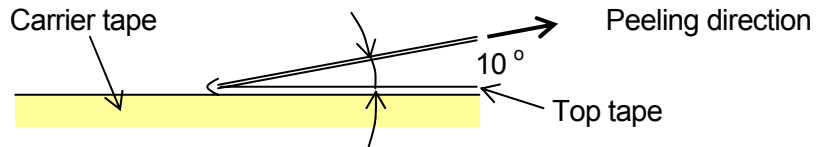

#### 11.3.2 Quantity in Taping

Quantity in Taping: 10,000 pcs./reel

#### 11.3.3. Tape packaging

- (1) ESD Suppressor side shall be facing upward.
- (2) ESD Suppressor shall not be sticking to top tape and bottom tape.
- (3) ESD Suppressor shall be easy to take out from carrier tape and chip hole or sprocket hole shall not have flash and break.

#### 11.4. Outer Packaging

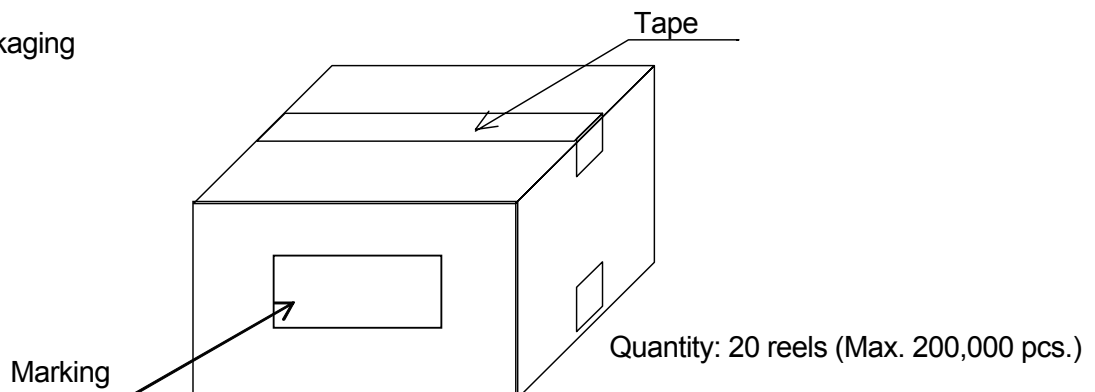

\* When taping shall not reach Max. or quantity, the remaining empty space shall be buried with buffer material.

\* When the quantity shall be few, alternative packaging methods may be used. No problem must occur during the exportation of the product.

#### 11.5. Marking

At least production country is displayed in English.

##### (1) Side of reel (Marking shall be on one side)

1)Part name, 2)Part number, 3)Quantity, 4)Lot number, 5)Maker name, 6) Poduction country

##### (2)Packaging box

1)Customer name, 2)Part name, 3)Part number, 4)Customer part number, 5)Quantity.

6)Maker name, 7)Poduction country