

Tous droits strictement réservés. Reproduction ou communication a des tiers interdite sous quelque forme que ce soit sans autorisation écrite du propriétaire. Propriété de c FCI. Droits de reproduction FCI.

All rights strictly reserved. Reproduction or issue to third parties in any form whatever is not permitted without written authority from the proprietor. Property of FCI. Copyright FCI.

**A**  
**FCI**

A

B

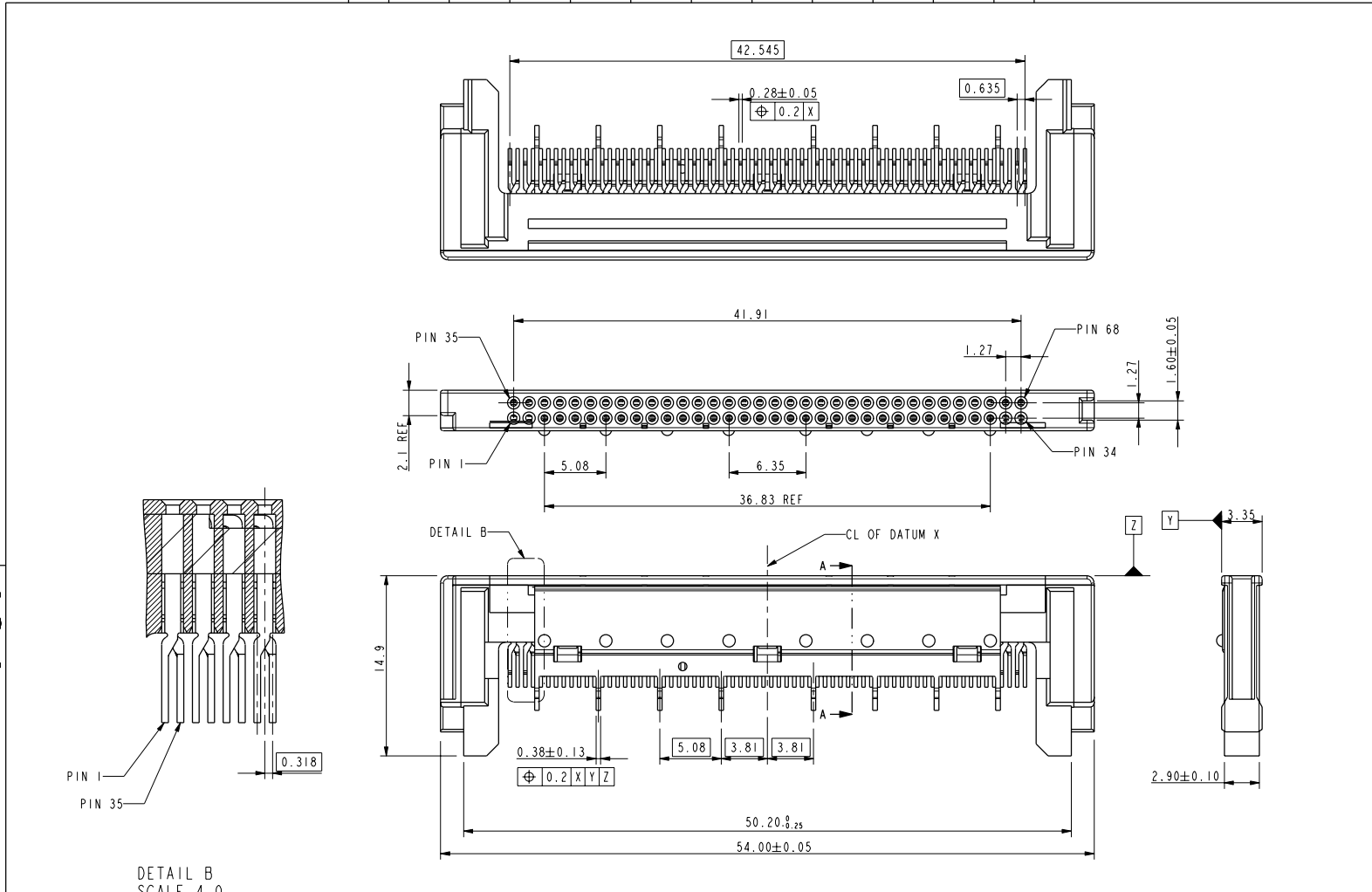

PRELIMINARY

THIS FILE WAS ORIGINALLY CREATED IN THE PRO ENGINEER ENVIRONMENT AND ANY FUTURE REVISIONS TO THIS FILE MUST BE MADE IN THE PRO ENGINEER ENVIRONMENT

mat'l code				tolerances unless otherwise specified		CUSTOMER		 www.fciconnect.com	
ltr	ecr no.	dr	date	linear	.X±0.3	COPY		title	
1		TAI	10/03/'02		.XX±0.13	projection		68P CARDBUS RECEPTACLE ASS'Y	
2		TAI	10/16/'02	angles	.XXX±0.05			product family PCMCIA code	
3		TAI	11/01/'02	dr	0°±2°	MM		size	
4		TAI	01/30/'03	enrg	KENNY TAI 10/03/'02	scale 1.000		dwg no 10014747	
				chr	KENNY TAI 10/03/'02			sheet 1 of 2	
				appd					
sheet index	revision sheet	4	4						
		1	2						

form no. 7530-001-103

cage code 22526

1 | 2

3

4

1 | 2

3

4

Tous droits strictement reserves. Reproduction ou communication a des tiers interdite sous quelque forme que ce soit sans autorisation écrite du propriétaire. Propriete de c FCI. Droits de reproduction FCI.

All rights strictly reserved. Reproduction or issue to third parties in any form whatever is not permitted without written authority from the proprietor. Property of FCI. Copyright FCI.

PRODUCT NUMBER	BOARD OFFSET DIM C	PACKING
10014747-001	0	SEE NOTE 4 FOR DETAIL DESCRIPTION
10014747-002	0.3	
10014747-003	0.6	

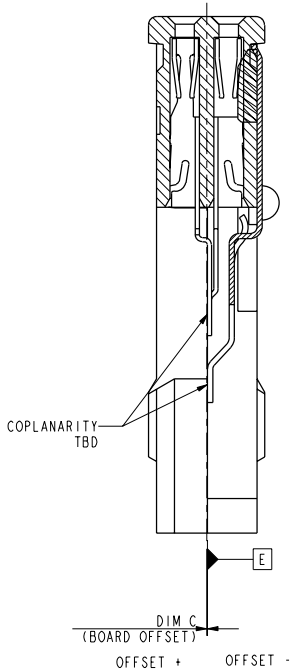

SECTION A-A  
SCALE 5.000

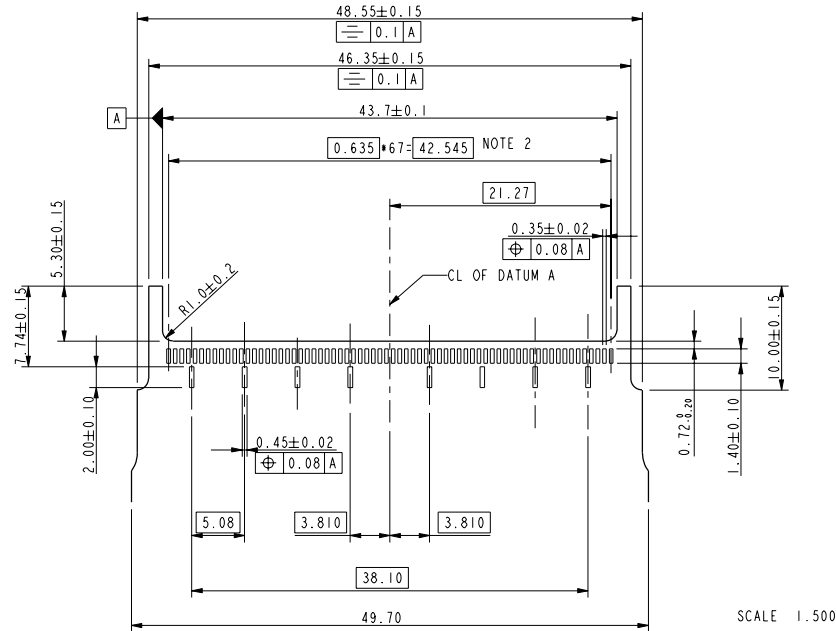

SCALE 1.500

NOTE:

- MATERIAL:  
CONTACT: PHBR 0.12t  
HOUSING: LCP UL 94V-0, BLACK  
FINISH:  
CONTACT: ALL OVER --- Ni UNDER 0.5 MICRON.  
CONTACT --- Au PLATING 0.4 MICRON.  
SOLDER TAIL --- TIN LEAD 2.5 MICRON.
- MAX. BOW OF PCB ON THIS DIMENSION IS 0.1mm.
- MATED CONNECTOR SHOULD BE BASED ON JEIDA AND PCMCIA SPECIFICATION.
- PACKING DETAIL:  
-XXX USE TRAY PACKAGE 1872 PCS / CARTON.  
-XXXT USE TAPE AND REEL 750 PCS / REEL.  
-XXXS USE TRAY PACKAGE 200 PCS / CARTON.  
-XXXA USE TAPE AND REEL 600 PCS / REEL.

PRELIMINARY

THIS FILE WAS ORIGINALLY CREATED IN THE PRO ENGINEER ENVIRONMENT AND ANY FUTURE REVISIONS TO THIS FILE MUST BE MADE IN THE PRO ENGINEER ENVIRONMENT

mat'l code				tolerances unless otherwise specified		CUSTOMER	
lfr	ecr no.	dr	date	linear	.X±0.3	COPY	www.fciconnect.com title 68P CARDBUS RECEPTACLE ASS'Y product family PCMCIA code size dwg no 10014747 sheet 2
4				linear	.XX±0.13	projection	
				angles	.XXX±0.05		
				dr	KENNY TAI 10/03/'02	MM scale 1.000	
				enrg	KENNY TAI 10/03/'02		
				chr	KENNY TAI 10/03/'02		
				appd			
sheet index	revision sheet						

form no. 7530-001-103

cage code 22526