

FLEX-LOC



DESCRIPTION

A flexible fixing resistant to oils, the majority of solvents and ageing.

OPERATION

The design of the FLEX-LOC mount gives the following basic characteristics:

- The rubber works in:
 - compression (axial),
 - shear (radial),
 - compression/shear according to the fixing method.

Advantages :

- 80 % reduction of vibrational energy transmitted from normal structural frequencies.
- Simple and economical.
- Simple to fix.
- Light weight.

APPLICATIONS

FLEX-LOC are suitable for the fixing of sheets, frameworks, engines, ventilators, electronic equipment, computers, etc.

DIMENSIONS CHARACTERISTICS

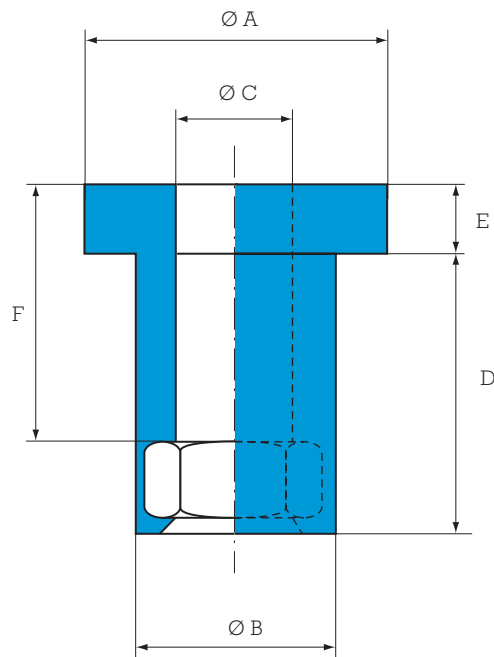

Paulstra reference	Barry Controls reference *	Nut	Ø A mm	Ø B mm	Ø C mm	D mm	E mm	F mm
530909 03	Q3	M3	9	7.2	3.4	9	2.5	8
530909 04	Q4	M4	12	9.3	4.4	11.5	3	10.5
530909 05	Q5	M5	15	10.2	5.4	14.5	3.5	13
530909 06	Q6	M6	18	12.7	6.4	17	4	15
530909 07	Q8	M8	24	16.5	8.4	22	5	19.5

* Barry Controls references are given as an indication.

OPERATING CHARACTERISTICS

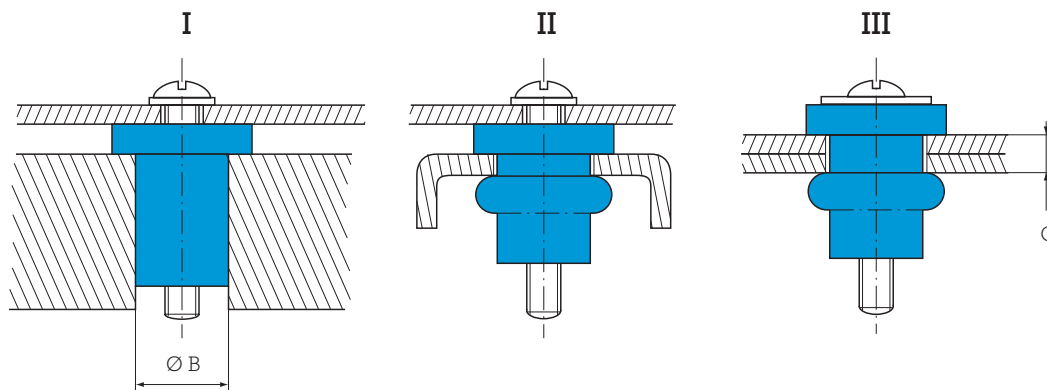

Paulstra reference	Barry Controls reference *	Clearance cole Ø B	Plate thickness G mm	Torque range		Static load (daN)		
				I Nm	II ou III Nm	I	II ou III	
						Compression/ shear	Compression	Shear
530909 03	Q3	7,2-7,5	0.6-2.5	0.5	0.4	1	5	2.5
530909 04	Q4	9,3-9,6	0.8-3.3	0.6	0.5	1	7	3.5
530909 05	Q5	10,2-10,5	0.8-4.3	1.0	0.6	1.5	10	5
530909 06	Q6	12,7-13,0	1.5-5.0	3.5	0.9	3	14	7
530909 07	Q8	16,5-16,8	1.5-6.5	4.0	1.8	5	28	14

* Barry Controls references are given as an indication.

1 kg ≈ 1 daN

