

Farnell

P.C.B. Guillotine Order Code 483 - 930
Replacement Blades Order Code 483 - 941

Cutting Capacity

Material	Max. thickness
S.R.B.P. & fibre glass boards	2mm
Aluminium	16swg (1.6mm)
Brass	1mm

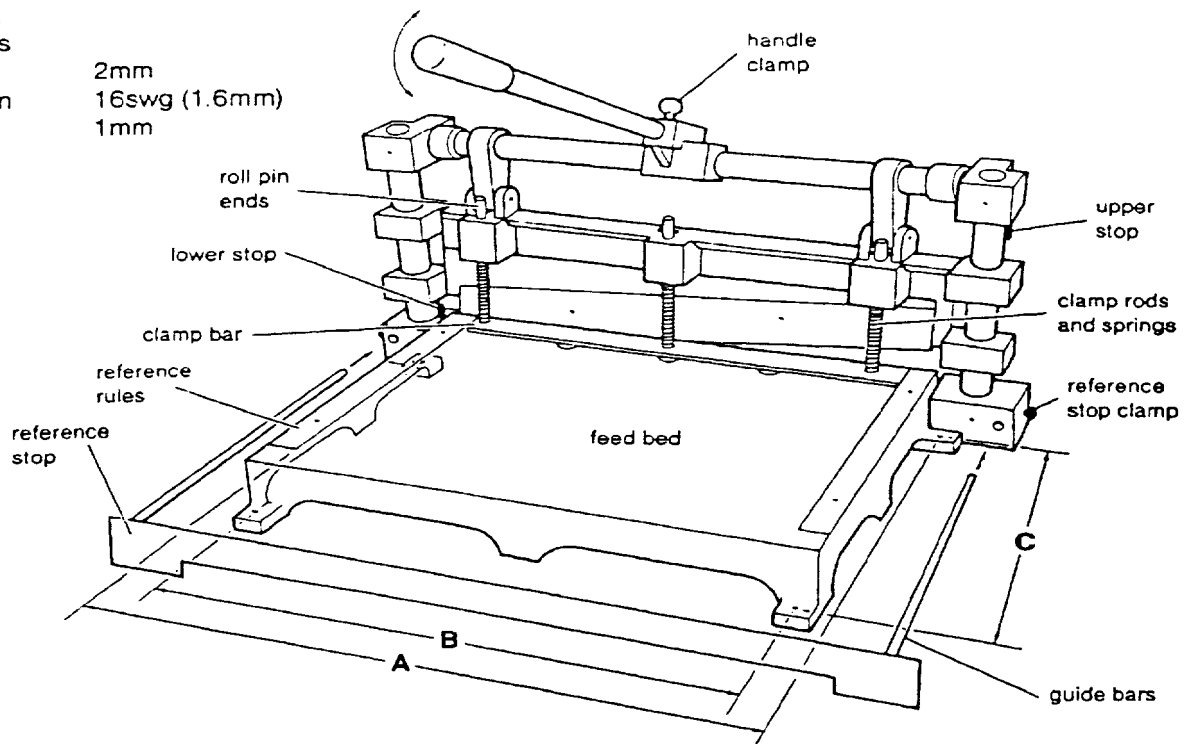

Fig. 1.

Mounting Details

It is recommended that the shear is securely mounted by its fixing feet before operations commence, with the rear of the shear facing a wall to avoid approach to the rear of the machine. The shear should be mounted on a table top via the 4 x 8mm fixing holes using 1/4 inch or 6mm screws with washers. Dimensions A=543mm, B=492mm, C=305mm.

Operating Procedure

Ensure that the handle is firmly clamped to the top bar of the shear by means of the handle wing clamp. With the handle in the vertical position place the P.C.B. to be cut on the feed bed against the reference rule and align to the cutting size. Hold the P.C.B. with one hand and pull the handle down slowly, the P.C.B. will firstly be clamped by the clamp bar and then further down movement to the horizontal position will then cut the P.C.B. Return the handle to the vertical position to release the clamp holding the P.C.B.

References

When cutting use reference rules and/or the sliding reference stop to give repeatable, accurate measurement to the cutting edge. Check that the reference rules are at right angles to the cutting edge by releasing their clamping screws and aligning with an engineers' try square.

Slide the guide bars of the reference stop into the holes indicated in Fig. 1. Rest the lip of the reference stop on the feedbed surface and lock the guide bars in the required reference position using the stop clamps. The reference stop may also be used on the other side of the shear.

Blade Replacement

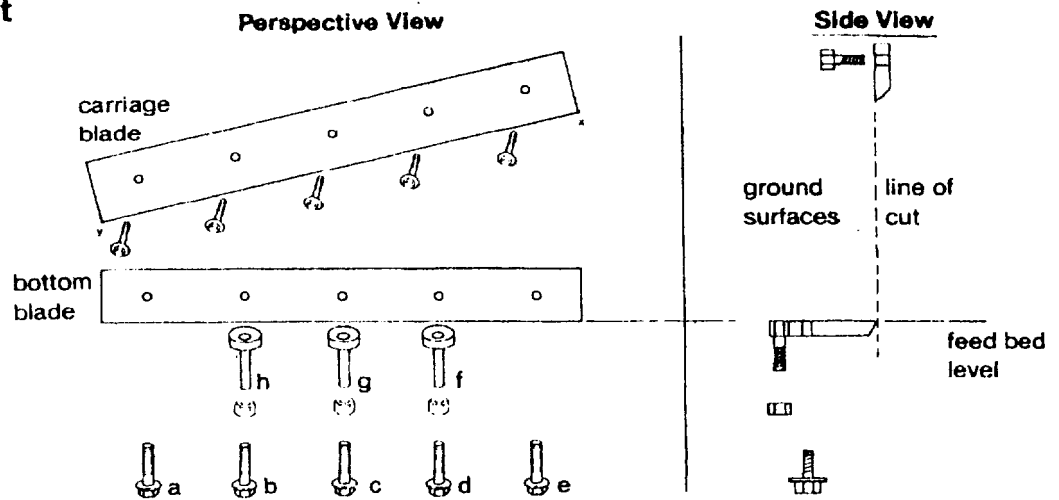

Fig. 2.

Fig. 2 shows perspective and side views of the blades and screw assembly. Replace blades as follows:-

1. Remove operating handle.
2. Gain easier access to blades by unscrewing the plastic guard and removing the clamp bar.
3. Remove clamp bar by unscrewing the clamp rods (rotating anticlockwise at the roll pin ends Fig. 1). Lift the rods out of the carriage and extract the springs and clamp bar.
4. Loosen the reference rule fixing screws and slide rules away from the cutting line of the blades.
5. Release the three eccentrics f to h away from the bottom blade.
6. Remove both old blades by unscrewing screws a to e and the five carriage blade screws.
7. Clean the blade mounting surfaces of any accumulated dust, dirt and debris. Clean excess grease from new blades.
8. Set new bottom blade onto its mounting surface ensuring the cutting edge and taper is positioned as shown in the side view. Loosely fit screws a to e.
9. Fit and tighten new carriage blade with the leading edge and taper as shown in the side view.
10. Lower the carriage blade until point x is just below feed bed level. If necessary adjust the lower stops. (see Fig. 1).
11. Slide the bottom blade against the carriage blade and tighten screw e.
12. Raise the carriage blade until point y is just below feed bed level, then slide the bottom blade against the carriage blade and tighten screw a. Refit and clamp handle.
13. Adjust the eccentric g so that it presses against the bottom blade, moving it towards the line of cut.
14. Check that the centre part of the blades (by eccentric g) will cut standard writing paper (approx. 0.1mm thick), adjusting eccentric g further if necessary. Tighten screw c.
15. Adjust eccentrics f and h in a similar fashion so that paper can be cut cleanly along the complete blade length. Tighten screws b and d.
16. Ensure all screws are secure, locking eccentrics h to f with the nuts underneath the feedbed.
17. Check the condition of the foam strip on the bar clamp.
18. Replace clamp bar springs and safety guard.
19. Reset reference rules as described under 'references'.

Blade Resetting

Should the shear fail to cut softer and thinner materials (eg. after a long period of cutting harder boards and metals), then the bottom blade can be reset by adjusting the eccentrics f to h. To reset follow the instructions under blade replacement, with the exception that the carriage blade remains fitted.