



PART NO.

37-02L-4-TGG

REVISIONS

ECN #	REV	DESCRIPTION	DRAWN	DATE	CHECKD	DATE	APPRVD	DATE
-	A	RELEASED	Shiv	03/9/07	Suresh	03/9/07	G. C	18/9/07

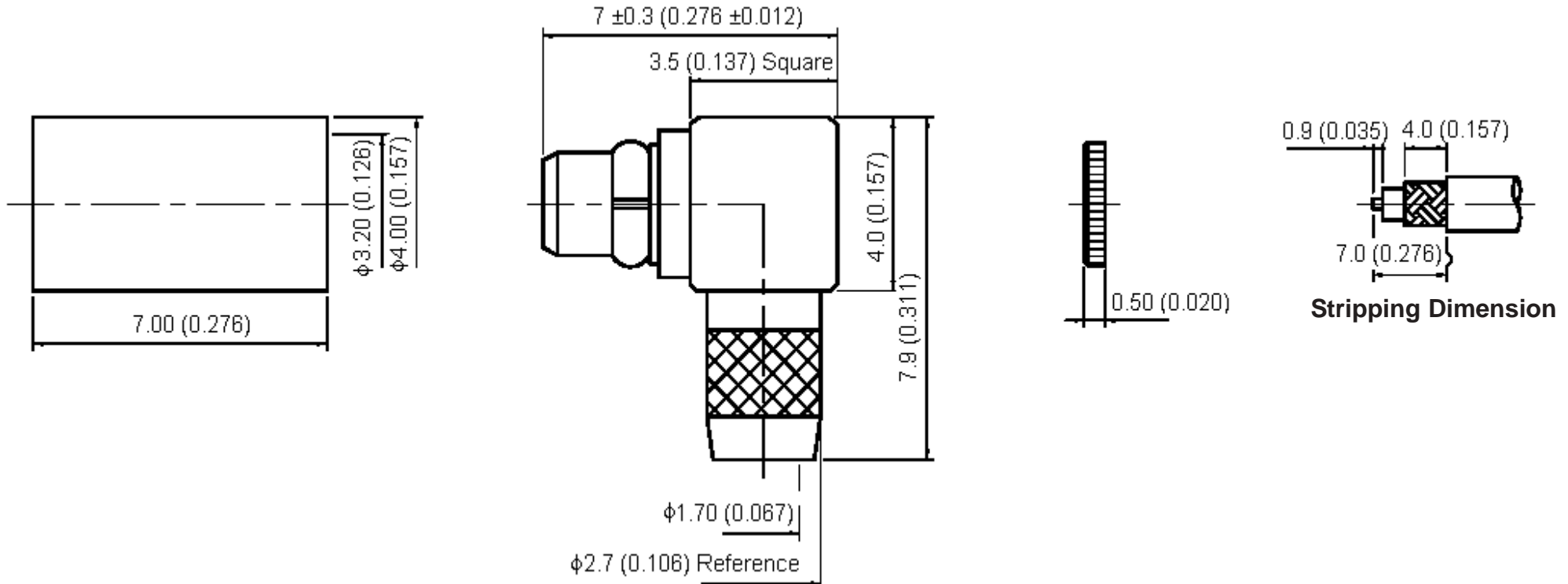

Dimensions : Millimetres (Inches)

Specifications:

- Bodies : Brass per JIS-C3604
Beryllium copper per ASTM B196 UNS C17300.
- Centre Contact : Brass per JIS-C3604.
- Insulation : PTFE per ASTM D1457 and ASTM D1710.
- Crimp Ferrule : Brass per JIS-C2700.
- Connector interface per BS EN 122340.
- Part to be clean and free of burrs.

This data sheet and its contents (the "Information") belong to the Premier Farnell Group (the "Group") or are licensed to it. No licence is granted for the use of it other than for information purposes in connection with the products to which it relates. No licence of any intellectual property rights is granted. The Information is subject to change without notice and replaces all data sheets previously supplied. The Information supplied is believed to be accurate but the Group assumes no responsibility for its accuracy or completeness, any error in or omission from it or for any use made of it. Users of this data sheet should check for themselves the Information and the suitability of the products for their purpose and not make any assumptions based on information included or omitted. Liability for loss or damage resulting from any reliance on the Information or use of it (including liability resulting from negligence or where the Group was aware of the possibility of such loss or damage arising) is excluded. This will not operate to limit or restrict the Group's liability for death or personal injury resulting from its negligence. SPC MULTICOMP is the registered trademark of the Group. © Premier Farnell plc 2007.

TOLERANCES:

UNLESS OTHERWISE SPECIFIED, DIMENSIONS ARE FOR REFERENCE PURPOSES ONLY.

DRAWN BY:	DATE:
Shivakumar.B	03/09/07
CHECKED BY:	DATE:
Suresh	03/09/07
APPROVED BY:	DATE:
G.Cook	18/09/07

DRAWING TITLE:

37-02L-4-TGG

SIZE A	DWG NO. M10000522	ELECTRONIC FILE 1169667_DWG	REV A
SCALE: NTS	U.O.M.: mm (Inches)	SHEET: 1 OF 2	



PART NO.

37-02L-4-TGG

REVISIONS

ECN #	REV	DESCRIPTION	DRAWN	DATE	CHECKD	DATE	APPRVD	DATE
-	A	RELEASED	Shiv	03/9/07	Suresh	03/9/07	G. C	18/9/07

Specification Table

Number	Description	Material	Finish	Part Number
1	Crimp Ferrule	Brass	Gold	37-02L-4-TGG
2	Washer	Beryllium copper	Gold 3μ" Minimum	
3	Insulation	PTFE	None	
4	Centre Contact	Brass	Gold 30μ" Minimum	
5	Body I		Gold 3μ" Minimum	
6	Body II			
7	Cap			

<http://www.farnell.com>

<http://www.newark.com>

<http://www.cpc.co.uk>

This data sheet and its contents (the "Information") belong to the Premier Farnell Group (the "Group") or are licensed to it. No licence is granted for the use of it other than for information purposes in connection with the products to which it relates. No licence of any intellectual property rights is granted. The Information is subject to change without notice and replaces all data sheets previously supplied. The Information supplied is believed to be accurate but the Group assumes no responsibility for its accuracy or completeness, any error in or omission from it or for any use made of it. Users of this data sheet should check for themselves the Information and the suitability of the products for their purpose and not make any assumptions based on information included or omitted. Liability for loss or damage resulting from any reliance on the Information or use of it (including liability resulting from negligence or where the Group was aware of the possibility of such loss or damage arising) is excluded. This will not operate to limit or restrict the Group's liability for death or personal injury resulting from its negligence. SPC MULTICOMP is the registered trademark of the Group. © Premier Farnell plc 2007.

TOLERANCES:
UNLESS OTHERWISE SPECIFIED, DIMENSIONS ARE FOR REFERENCE PURPOSES ONLY.

DRAWN BY:	DATE:
Shivakumar.B	03/09/07
CHECKED BY:	DATE:
Suresh	03/09/07
APPROVED BY:	DATE:
G.Cook	18/09/07

DRAWING TITLE:			
37-02L-4-TGG			
SIZE	DWG NO.	ELECTRONIC FILE	REV
A	M10000522	1169667_DWG	A
SCALE: NTS	U.O.M.: mm (Inches)	SHEET: 2 OF 2	