

## LIQUID LEVEL SENSORS

### LS Series - Horizontal Level Sensor

## LS403-51

#### Design Features

- High or low level sensing
- Internal fit & External Fitting
- Reed Switch reliability
- Silicone sealing components
- Easy installation



#### Product Comments

- WRC- Potable Water
- UL listed model, File E98428
- Normally open or normally closed by rotating through 180°
- Suitable for a wide range of liquids
- Interface option available
- Polypropylene Materials

#### Typical Applications

- Drinking water level
- Coolant level indication
- Cooling systems
- Water high or low Level
- Waste Water Level

#### Material, Design and Operation

Mounting:	Side Entry
Material:	Polypropylene
Fitting	Internal & External Fitting
Contact Form:	Form A - SPST
Contact Material:	Ruthenium
Maximum Switching Volts:	250 VAC
Maximum Switching Current:	1.0
Maximum Power:	15 Watts
Housing Temperature Range °C:	80
Housing Material:	Glass Filled Polypropylene
Housing Colour:	Charcoal
Float Material:	Glass Filled Polypropylene
Connection Type:	Stripped Cables
Cable Type:	2 x 18AWG 32/0.2mm PVC insulated 0.5m long to UL/CSA/BS6361
Cable Colour:	Black/Black
Minimum Specific Gravity:	0.65
Operating Temperature Range °C:	80
Operating Pressure BAR:	4
Medium/ Liquid:	Drinking Water (Potable Water), Water
Sealing Components:	Silicone
Mounting Shock:	50g for 11ms duration
Mounting Vibration:	35g up to 500Hz
Operate Mode:	N/C with float Horizontal
Approvals:	UL

## Line Drawing

### Internal Fitting

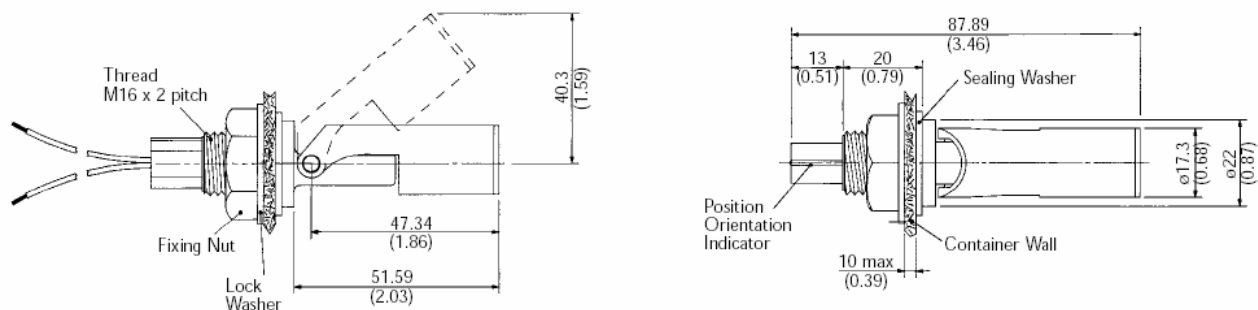

#### INTERNAL FITTING

CONTAINER WALL  
(THICKNESS MAX 10mm, MIN 1mm)

NOTE! DRILL 0.65" OR 16.5mm HOLE,  
ENSURE FREE FROM SWarf AND  
SHARP EDGES.

LOCK WASHER

FIXING NUT

NOTE! MAX TORQUE 3lbs/ft  
OR 4Nm.

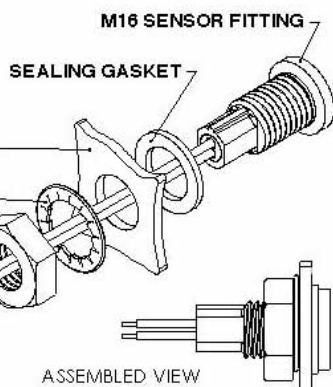

### External Fitting

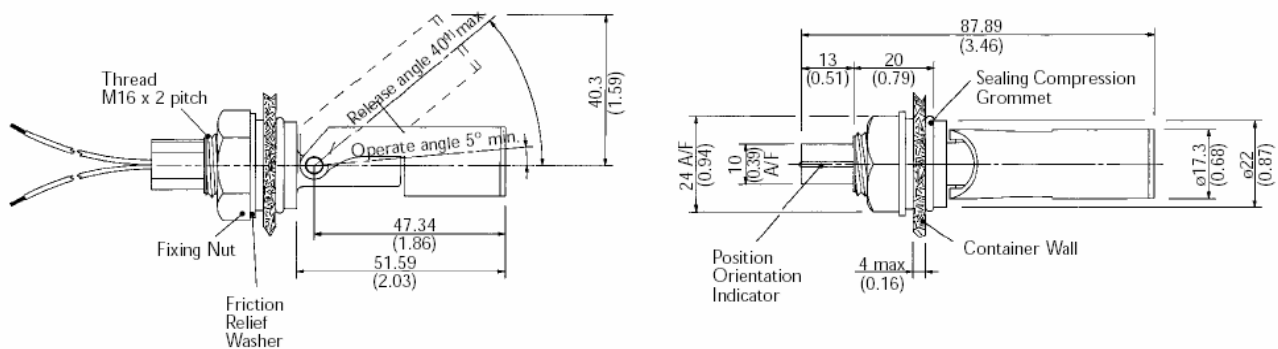

#### EXTERNAL FITTING

CONTAINER WALL  
(THICKNESS MAX 4mm, MIN 1mm)

NOTE! DRILL 0.9" OR 23mm HOLE,  
ENSURE FREE FROM SWarf AND  
SHARP EDGES.

SEALING GROMMET

FRICTION RELIEF  
WASHER

FIXING NUT

NOTE! MAX TORQUE 2lbs/ft  
OR 2.67Nm.

