

Standard Heavy Duty Limit Switches FD/FP/FL

Heavy duty limit switches with snap-action contacts and positive break according to BS/EN60947-5-1.

- Bifurcated contacts for low resistance and high reliability – suitable for switching low-level electronic currents
- Double-break contacts with electrically separate NO and NC circuits in conformity with VDE 0660 part 206
- 10A 500VAC/600VDC rated
- Lever types can be user-set to switch by clockwise movement only, anti-clockwise only or both
- Turret head position rotatable in 90° increments
- Centre-position indicator arrow – lever actuators
- Wide range of actuators
- Single and triple cable entry models
- Removable contact block for ease of wiring
- Metal or plastic housing options
- IP66 according to BS EN60947-1
- FD and FP dimensions in accordance with EN50041
- UL and CUL approved

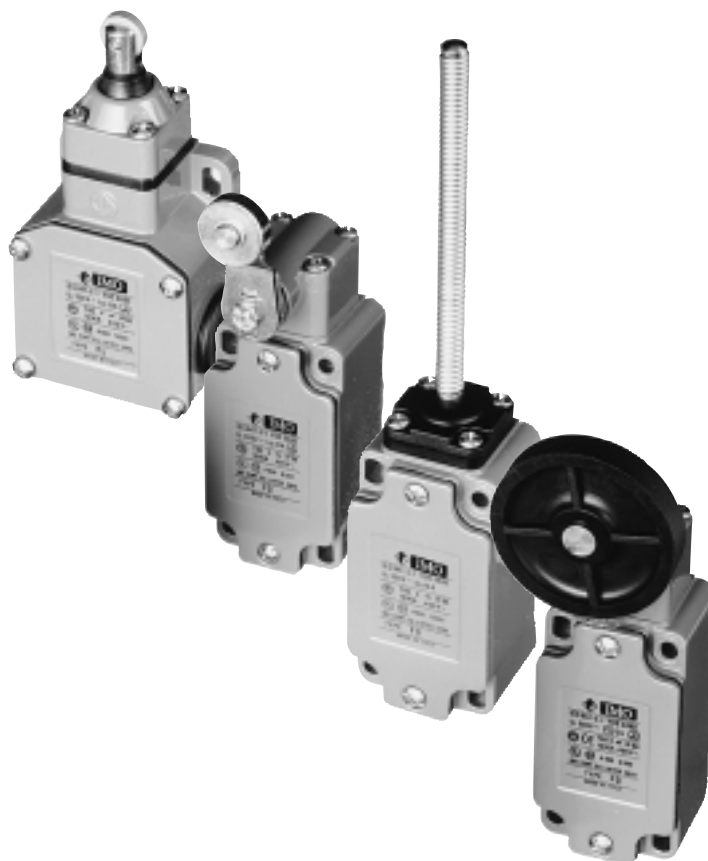

Options and ordering codes

	FD	5	01	
Heavy duty metal housing	FD			- Standard actuators - see following pages for type options
Heavy duty plastic housing	FP			38 Specify lever type for lift-style switches
Triple-entry metal housing	FL			VFL313 Fixed position roller
Snap-action contacts, 1NO + 1NC		5		VFL353 Single adjustment roller
Slow-action, break before make 1NO + 1NC		6		VFL354 Dual adjustment roller
Slow-action, make before break 1NO + 1NC		7		- Standard actuators - see following pages for type options
Slow-action contacts, 2NC		9		385 Specify lever type for life-style switches
Slow-action contacts, 2NO		10		VFL313 Fixed position roller
Snap-action contacts, 2NC		11		VFL353 Single adjustment roller
Slow-action contacts, break before make 2NC + 1NO		20		VFL354 Dual adjustment roller
Slow-action contacts, 3NC		21		
Slow-action contacts, break before make 1NC + 2NO		22		
Snap-action contacts, 2NO + 2NC		2		

Please note:
Positive break applies to the NC contacts of types 5, 6, 7, 9, 11, 20, 21 and 22 only.

Contact ratings

BS/EN 60947-5-1		
AC15 – Control of AC electromagnetic loads > 72VA sealed – replaces AC11	230VAC	6A
	400VAC	4A
	500VAC	1A
DC13 – Control of DC electromagnetic loads where the time taken to reach 95% of the rated current is equal to 6 times the power of the load (where P ≤ 50W) – replaces DC11	24VDC	6A
	125VDC	1.1A
	250VDC	0.4A

Terminal connections

Terminal screws: M3.5 with rising cable clamps.

Standard contacts: (type 5) NO: 13–14 NC: 21–22

Note: The positive break of the type 5 contact block applies to the NC contacts only. Connections to safety circuits should NOT be made using the NO contacts.

To ensure positive breaking of the contacts, exceed the pre-travel by 1.5mm or 25° according to the model. Maximum screw tightening torque 0.8Nm (8Kgcm)

Standard Heavy Duty Limit Switches FD/FP/FL continued



Specification

Rated thermal current I _{th}	10A
Rated working voltage	500VAC/600VDC
Maximum operating frequency	6000/hour
Mechanical life	>20 million operations
Contact form	1NO + 1NC
Initial contact resistance	<25 mOhms
Contact gap	>2.5mm (2 x 1.25mm conforming to VDE 0660 part 206)
Contact material	silver
Dielectric strength	2000VAC, 50/60Hz for 1 minute between open contacts 2000VAC, 50/60Hz for 1 minute between current-carrying parts and ground
Protection rating	IP65
Ambient operating temperature	-25 to +80 deg. C
Ambient humidity	95% R.H.
Maximum wire size	2 x 1.5mm ² flexible, 2 x 2.5mm ² solid
Housing material	FD/FL die-cast metal alloy, FP: self-extinguishing, glass-reinforced, thermoplastic resin
Conduit entry	PG 13.5

Programmable head – lever operation models

All limit switches with lever operation in the FD/FP/FL ranges can be user-set to switch by clockwise rotation only, anti-clockwise only or both. To change the operation, which is factory set to switch in both directions, the four screws securing the turret head should be loosened, the head removed and the internal piston rotated through 90°. The head should then be replaced.

The models to which this applies are: 531; 532; 533; 535; 536; 538; 551; 552; 553.

Figure 1 shows the piston position for switching in both directions, figure 2 for clockwise only and figure 3 for anti-clockwise only.

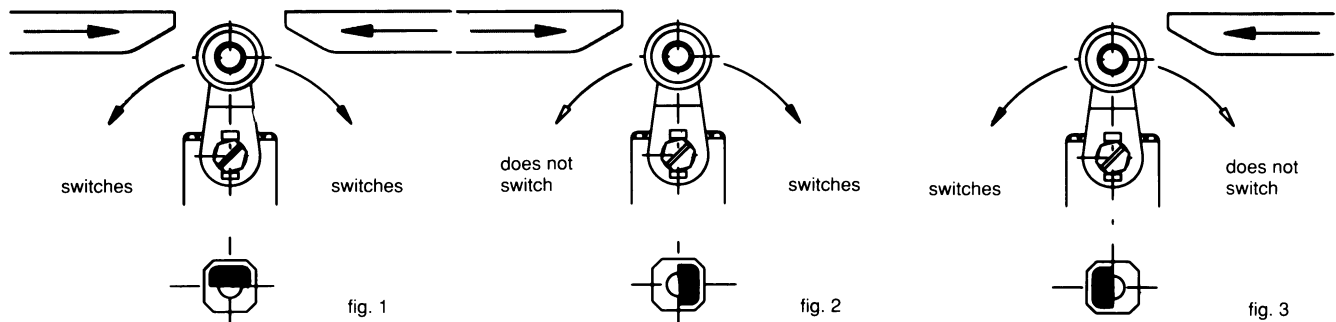

Standard actuator options – FD and FP series

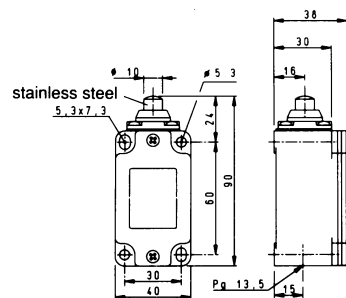

Actuator type 01

Piston plunger

Operating force min.	OF	820g
Pre-travel	PT	2mm
Over-travel	OT	4mm
Movement differential	MD	1mm
Operating point	OP	22mm
Operating speed max.	OS	0.5m/s

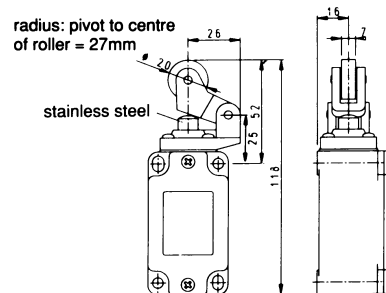

Actuator type 02

One-way roller - top actuated

Operating force min.	OF	615g
Pre-travel	PT	2.9mm
Over-travel	OT	5.6mm
Movement differential	MD	1.6mm
Operating point	OP	49.1mm
Operating speed max.	OS	0.5m/s using a 30° cam

Note: ø20mm plastic roller as standard, ø20mm metal roller actuator part no.: 021

Standard Heavy Duty Limit Switches FD/FP/FL continued



Standard actuator options – FD and FP series continued

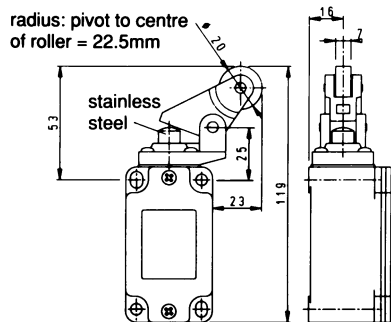

Actuator type 05

One-way roller-side actuated

OF 615g
PT 2.9mm
OT 5.6mm
MD 1.6mm
OP –
OS 0.5m/s using a 30° cam
Note: ø20mm plastic roller as standard, ø20mm metal roller actuator part no.: 051

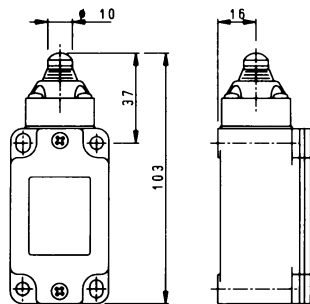

Actuator type 10

Sealed piston plunger

OF 1125g
PT 2mm
OT 4mm
MD 1mm
OP 35mm
OS 0.5m/s

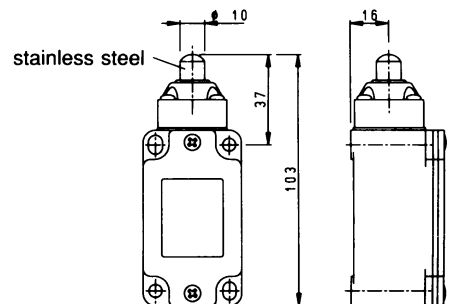

Actuator type 11

Long piston plunger

OF 820g
PT 2mm
OT 4mm
MD 1mm
OP 35mm
OS 0.5m/s

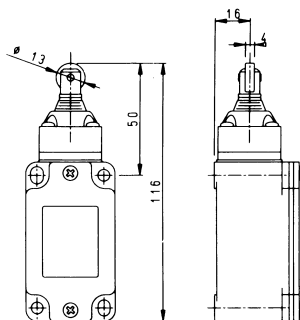

Actuator type 15

Sealed roller piston plunger

OF 1125g
PT 2mm
OT 4mm
MD 1mm
OP 48mm
OS 0.5m/s using a 30° cam
Note: ø13mm metal roller only

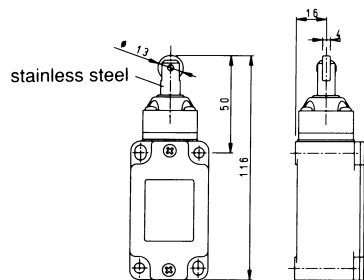

Actuator type 16

Roller piston plunger

OF 820g
PT 2mm
OT 4mm
MD 1mm
OP 48mm
OS 0.5m/s using a 30° cam
Note: ø13mm metal roller only

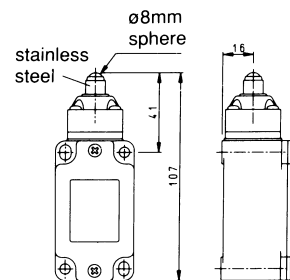

Actuator type 18

Rolling ball piston plunger

OF 820g
PT 2mm
OT 4mm
MD 1mm
OP 39mm
OS 0.5m/s

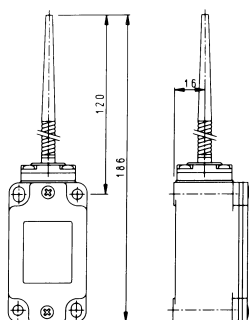

Actuator type 20

Sealed coil spring with flexible rod

OF 125g at 2/3 the length of the actuator
PT 14°
OT –
MD 7°
OP –
OS 1m/s

Notes: Not suitable for safety circuits
Not suitable for use with contact blocks 20, 21 or 22

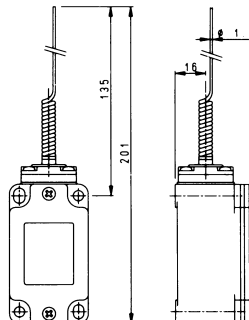

Actuator type 21

Sealed coil spring with cat's whisker

OF 92g at 2/3 the length of the actuator
PT 14°
OT –
MD 7°
OP –
OS 1m/s

Notes: Not suitable for safety circuits
Not suitable for use with contact blocks 20, 21 or 22

Standard Heavy Duty Limit Switches FD/FP/FL continued



Standard actuator options – FD and FP series continued

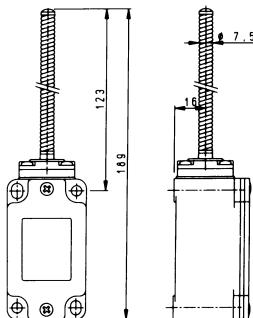

Actuator type 25 Sealed coil spring

OF 195g at 2/3 the length of the actuator
PT 14°
OT –
MD 7°
OP –
OS 1m/s

Notes: Not suitable for safety circuits
Not suitable for use with contact blocks 20, 21 or 22

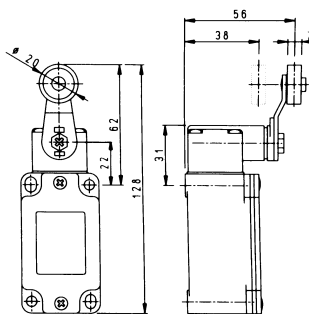

Actuator type 31 Roller-lever with small offset

OF 1530gcm
PT 30°
OT 45°
MD 14°
OP –
OS 1.5m/s using a 30° cam

Notes: 1. $\varnothing 20$ mm plastic roller as standard, $\varnothing 20$ mm metal roller actuator part no.:311; $\varnothing 35$ mm plastic roller actuator part no.:312; $\varnothing 50$ mm rubber roller actuator part no.:313.
2. Lever position adjustable over 360° in 10° increments

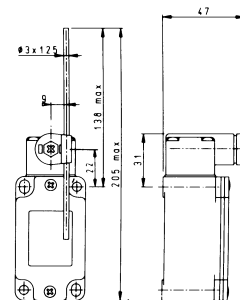

Actuator type 32 Adjustable round steel rod lever

Actuator type 33
Adjustable square steel rod lever (rod 3x3x125)
OF 1530gcm
PT 30°
OT 45°
MD 14°
OP –
OS 1.5m/s

Note: Lever position adjustable over 360° in 10° increments

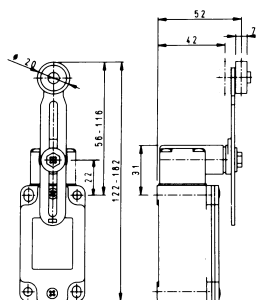

Actuator type 35 Adjustable roller lever

OF 1530gcm
PT 30°
OT 45°
MD 14°
OP –
OS 1.5m/s using a 30° cam

Notes: 1. $\varnothing 20$ mm plastic roller as standard, $\varnothing 20$ mm metal roller actuator part no.:351; $\varnothing 35$ mm plastic roller actuator part no.:352; $\varnothing 50$ mm rubber roller actuator part no.:353.
2. Lever position adjustable over 360° in 10° increments

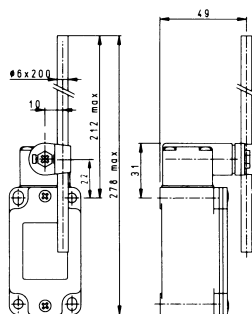

Actuator type 36 Adjustable glass-fibre rod lever

OF 1530gcm
PT 30°
OT 45°
MD 14°
OP –
OS 1.5m/s

Notes: 1. Not suitable for safety circuits.
2. Lever position adjustable over 360° in 10° increments

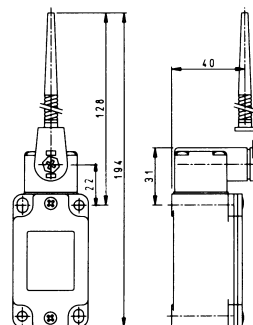

Actuator type 38+VFL34 Coiled spring lever with flexible rod

OF 1530gcm
PT 30°
OT 45°
MD 14°
OP –
OS 1.5m/s

Notes: 1. Not suitable for safety circuits.
2. Lever position adjustable over 360° in 10° increments

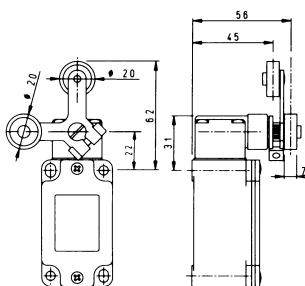

Actuator type 40 Dual roller lever with two stable free positions

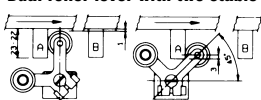

Specify lever type:
Double track (shown above) VFL42
Single track (not shown) VFL41
Steel rod lever VFL43

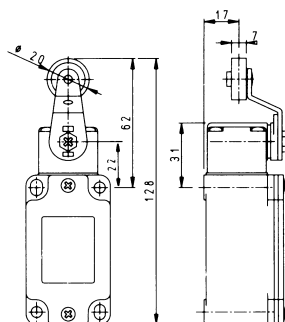

Actuator type 51 Roller-lever with large offset

OF 920gcm
PT 30°
OT 45°
MD 14°
OP –
OS 1.5m/s using a 30° cam

Notes: 1. $\varnothing 20$ mm plastic roller as standard, $\varnothing 20$ mm metal roller actuator part no.:511.
2. Lever position adjustable over 360° in 10° increments

Standard Heavy Duty Limit Switches FD/FP/FL continued



Standard actuator options – FD and FP series continued

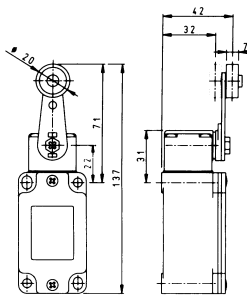

Actuator type 52

Roller lever without offset

OF	920gcm
PT	30°
OT	45°
MD	14°
OP	–
OS	1.5m/s

Notes: 1. $\varnothing 20$ mm plastic roller as standard, $\varnothing 20$ mm metal roller actuator part no.:521; $\varnothing 35$ mm plastic roller actuator part no.:522; $\varnothing 50$ mm rubber roller actuator part no.:523.
2. Lever position adjustable over 360° in 10° increments

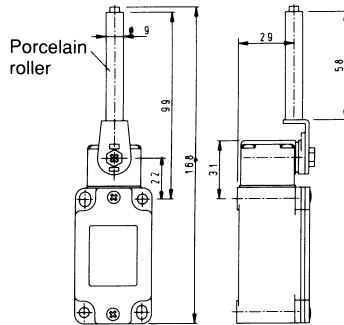

Actuator type 53

Porcelain roller lever

OF	615gcm
PT	30°
OT	45°
MD	14°
OP	–
OS	–

Note: Lever position adjustable over 360° in 10° increments

Only available in FD series (metal case), not FP series

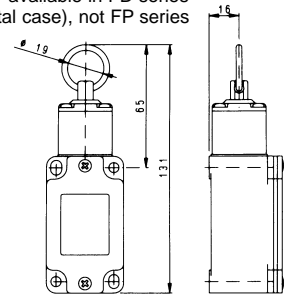

Actuator type 76

Rope

OF	2450g
PT	1.8mm
OT	6.4mm
MD	1mm
OP	66.8mm
OS	–

Note: Not suitable for safety circuits. For rope operated safety switches, see Safety Limit Switches data sheet on page 297

Standard actuator options – FL series

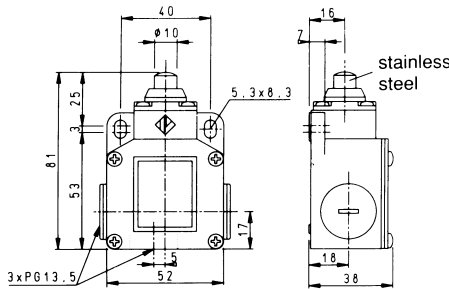

Actuator type 01

Piston plunger

OF	820g
PT	2mm
OT	4mm
MD	1mm
OP	23mm
OS	0.5m/s

radius: pivot to centre of roller = 27mm

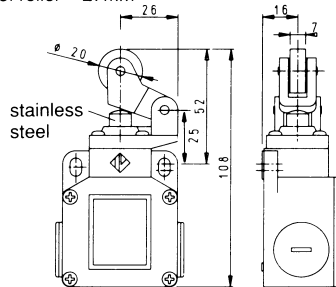

Actuator type 02

One-way roller - top actuated

OF	615g
PT	2.9mm
OT	5.6mm
MD	1.6mm
OP	49.1mm
OS	0.5m/s using a 30° cam

Note: $\varnothing 20$ mm plastic roller as standard, $\varnothing 20$ mm metal roller actuator part no.:021

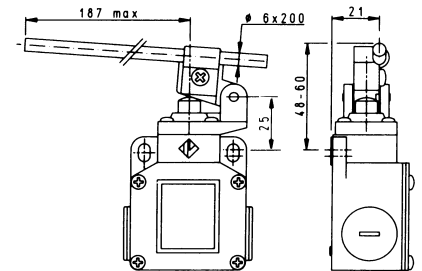

Actuator type 04

Piston plunger with adjustable glass-fibre rod lever

OF	} Variable – dependent on glass-fibre rod position
PT	
OT	
MD	
OP	
OS	

radius: pivot to centre of roller = 22.5mm

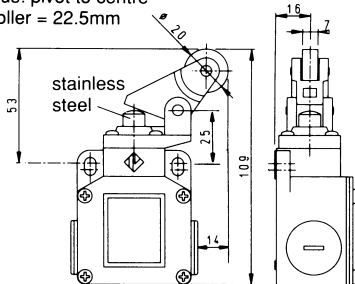

Actuator type 05

One-way roller - side actuated

OF	615g
PT	2.9mm
OT	5.6mm
MD	1.6mm
OP	–
OS	0.5m/s using a 30° cam

Note: $\varnothing 20$ mm plastic roller as standard, $\varnothing 20$ mm metal roller actuator part no.:051

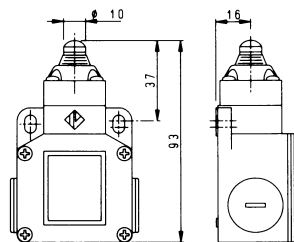

Actuator type 10

Sealed piston plunger

OF	1125g
PT	2mm
OT	4mm
MD	1mm
OP	35mm
OS	0.5m/s

Standard Heavy Duty Limit Switches FD/FP/FL continued



Standard actuator options – FL series continued

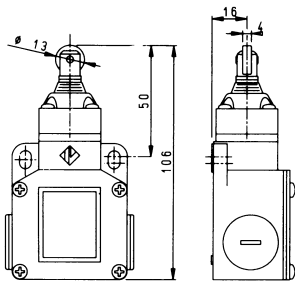

Actuator type 15
Sealed roller piston plunger
OF 1125g
PT 2mm
OT 4mm
MD 1mm
OP 48mm
OS 0.5m/s using a 30° cam
Note: ø13mm metal roller only

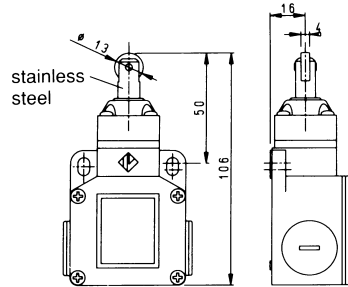

Actuator type 16
Roller piston plunger
OF 820g
PT 2mm
OT 4mm
MD 1mm
OP 48mm
OS 0.5m/s using a 30° cam
Note: ø13mm metal roller only

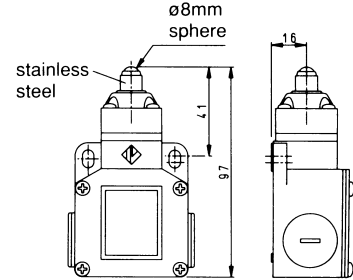

Actuator type 18
Rolling ball piston plunger
OF 820g
PT 2mm
OT 4mm
MD 1mm
OP 39mm
OS 0.5m/s

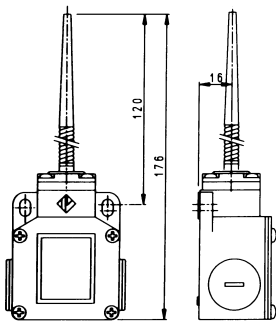

Actuator type 20
Sealed coil spring with flexible rod
OF 125g at 2/3 the length of the actuator
PT 14°
OT –
MD 7°
OP –
OS 1m/s
Notes: Not suitable for safety circuits
Not suitable for use with contact blocks 20, 21 or 22

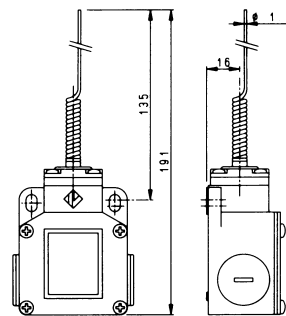

Actuator type 21
Sealed coil spring with cat's whisker
OF 92g at 2/3 the length of the actuator
PT 14°
OT –
MD 7°
OP –
OS 1m/s
Notes: Not suitable for safety circuits
Not suitable for use with contact blocks 20, 21 or 22

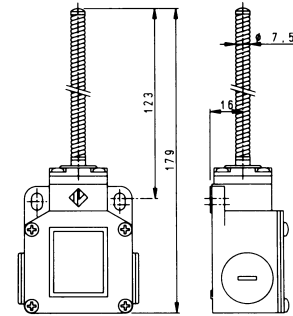

Actuator type 25
Sealed coil spring
OF 195g at 2/3 the length of the actuator
PT 14°
OT –
MD 7°
OP –
OS 1m/s
Notes: Not suitable for safety circuits
Not suitable for use with contact blocks 20, 21 or 22

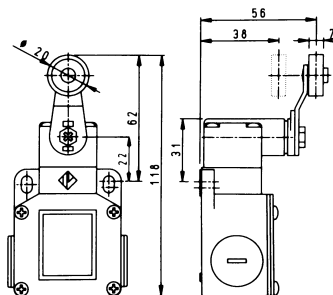

Actuator type 31
Roller lever with small offset
OF 1530gcm
PT 30°
OT 45°
MD 14°
OP –
OS 1.5m/s using a 30° cam
Notes: 1. ø20mm plastic roller as standard, ø20mm metal roller actuator part no.:311; ø35mm plastic roller actuator part no.:312; ø50mm rubber roller actuator part no.:313. 2. Lever position adjustable over 360° in 10° increments

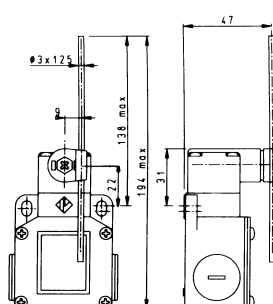

Actuator type 32
Adjustable round steel rod lever
OF 1530gcm
PT 30°
OT 45°
MD 14°
OP –
OS 1.5m/s
Note: Lever position adjustable over 360° in 10° increments

Standard Heavy Duty Limit Switches FD/FP/FL continued



Standard actuator options – FL series continued

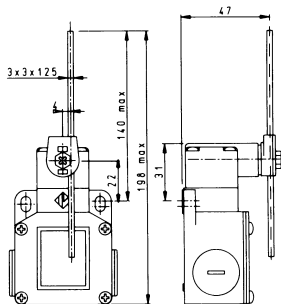

Actuator type 33
Adjustable square steel rod lever

OF 1530gcm
PT 30°
OT 45°
MD 14°
OP –
OS 1.5m/s
Note: Lever position adjustable over 360° in 10° increments

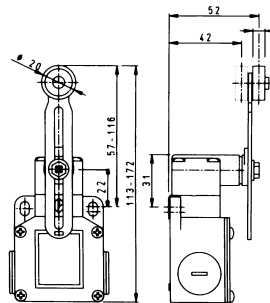

Actuator type 35
Adjustable roller lever

OF 1530gcm
PT 30°
OT 45°
MD 14°
OP –
OS 1.5m/s using a 30° cam
Notes: 1. ø20mm plastic roller as standard, ø20mm metal roller actuator part no.:351; ø35mm plastic roller actuator part no.:352; ø50mm rubber roller actuator part no.:353.
2. Lever position adjustable over 360° in 10° increments

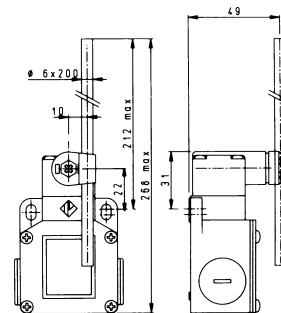

Actuator type 36
Adjustable glass-fibre rod lever

OF 1530gcm
PT 30°
OT 45°
MD 14°
OP –
OS 1.5m/s
Notes: 1. Not suitable for safety circuits.
2. Lever position adjustable over 360° in 10° increments

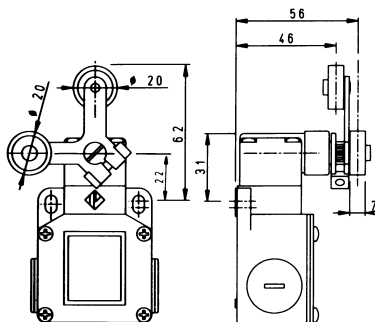

Actuator type 40
Dual roller lever with two stable free positions

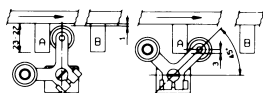

Specify lever type:
Double track (shown above) VFL42
Single track (not shown) VFL41
Steel rod lever VFL43

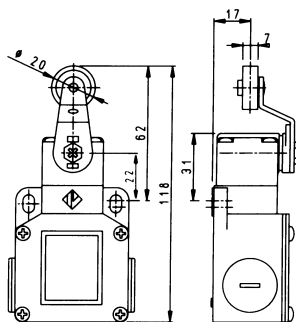

Actuator type 51
Roller lever with large offset

OF 920gcm
PT 30°
OT 45°
MD 14°
OP –
OS 1.5m/s using a 30° cam
Notes: 1. ø20mm plastic roller as standard, ø20mm metal roller actuator part no.: 511. 2. Lever position adjustable over 360° in 10° increments

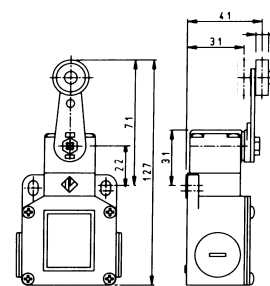

Actuator type 52
Roller lever without offset

OF 920gcm
PT 30°
OT 45°
MD 14°
OP –
OS 1.5m/s using a 30° cam
Notes: 1. ø20mm plastic roller as standard, ø20mm metal roller actuator part no.: 521; ø35mm plastic roller actuator part no.: 522; ø50mm rubber roller actuator part no.:523.
2. Lever position adjustable over 360° in 10° increments

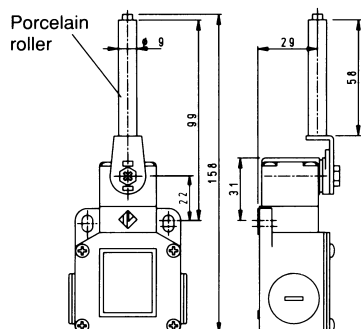

Actuator type 53
Porcelain roller lever

OF 615gcm
PT 30°
OT 45°
MD 14°
OP –
OS –
Note: Lever position adjustable over 360° in 10° increments

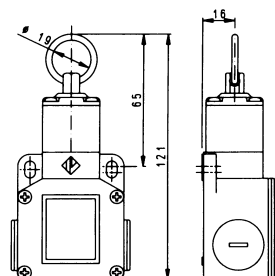

Actuator type 76
Rope

OF 2450g
PT 1.8mm
OT 6.4mm
MD 1mm
OP 66.8mm
OS –
Note: Not suitable for safety circuits. For rope operated safety switches, see Safety Limit Switches data sheet on page ????

Standard Heavy Duty Limit Switches FD/FP/FL continued



Glossary

The following is a glossary of terms in specifying actuator characteristics:

Operating force (OF)

The force applied to the actuator required to operate the switch contacts.

Releasing force (RF)

The value to which the force on the actuator must be reduced to allow the contacts to return to the normal position.

Total force (TF)

The force applied to the actuator required to reach the stopper from the free position.

Free position (FP)

The initial position of the actuator when there is no external force applied.

Operating position (OP)

The position of the actuator at which the contacts snap to the operated contact position measured with respect to the centres of the mounting holes.

Releasing position (RP)

The position of the actuator at which the contacts snap from the operated contact position to their normal position.

Total travel position (TTP)

The position of the actuator when it reaches the limit of travel – must not be exceeded.

Pretravel (PT)

The distance or angle through which the actuator moves from the free position to the operating position.

Overtravel (OT)

The distance or angle of the actuator movement beyond the operating position.

Movement differential (MD)

The distance or angle from the operating position to the releasing position.

Total travel (TT)

The sum of the pretravel and overtravel expressed by distance or angle.

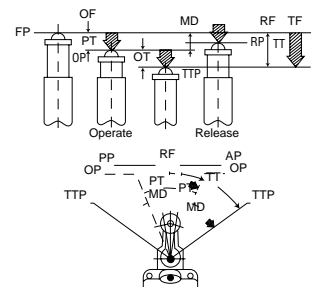

Lift-style switches

EXAMPLES

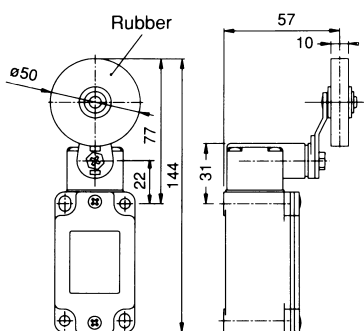

FD538 or FD5385 or FD938 + VFL313
FP538 or FP938 + VFL313
Turret type 38
Lever type VFL313 (fixed position roller)

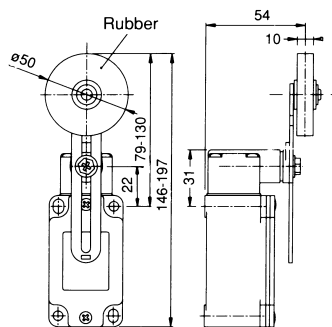

FD538 or FD5385 or FD938 + VFL353
FP538 or FP938 + VFL353
Turret type 38
Lever type VFL353 (single adjustment roller)

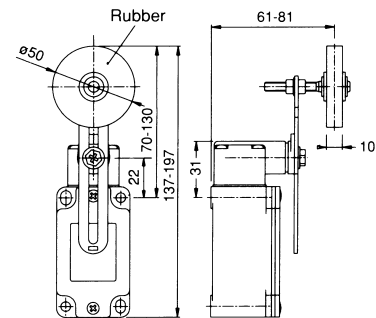

FD538 or FD5385 or FD938 + VFL354
FP538 or FP938 + VFL354
Turret type 38
Lever type VFL354 (dual adjustment roller)

- Three lever options.
- FL model also available with a choice of lever.
- Age-resistant and oil-resistant rubber rollers.
- Lever position adjustable over 360° in 10° increments.
- Head rotatable in 90° increments.

- User-selectable to switch by clockwise movement only, anti-clockwise only, or both.
- Glass-reinforced thermoplastic resin model (FP) double insulated for electrical safety.
- Die-cast metal alloy models (FD and FL) include earth terminal.









Types VFL353 and have a location slot at the end to lock the levers at full extension if required.

Standard Heavy Duty Limit Switches

FD/FP/FL continued



Replacement contact blocks

B5	1NO+1NC	Positive break <i>Snap action</i> standard contact block	
	$\begin{array}{c} 13 \quad 21 \\ \diagdown \quad \diagup \\ 14 \quad 22 \end{array}$		
B6	1NO+1NC	Positive break <i>Slow action</i> break before make	
	$\begin{array}{c} 13 \quad 21 \\ \diagdown \quad \diagup \\ 14 \quad 22 \end{array}$		
B7	1NO+1NC	Positive break <i>Slow action</i> make before break	
	$\begin{array}{c} 13 \quad 21 \\ \diagdown \quad \diagup \\ 14 \quad 22 \end{array}$		
B9	2NC	Positive break <i>Slow action</i> , contacts 11-12, 21-22 open at the same time	
	$\begin{array}{c} 11 \quad 21 \\ \diagdown \quad \diagup \\ 12 \quad 22 \end{array}$		
B14	2NC	Positive break <i>Slow action</i> , contacts 11-12 open first, further actuator travel causes contacts 21-22 to open	
	$\begin{array}{c} 11 \quad 21 \\ \diagdown \quad \diagup \\ 12 \quad 22 \end{array}$		
B10	2NO	<i>Slow action</i> , contacts 13-14, 23-24 close at the same time	
	$\begin{array}{c} 13 \quad 23 \\ \diagdown \quad \diagup \\ 14 \quad 24 \end{array}$		
B15	2NO	<i>Slow action</i> , contacts 13-14 close first, further actuator travel causes contacts 23-24 to close	
	$\begin{array}{c} 13 \quad 23 \\ \diagdown \quad \diagup \\ 14 \quad 24 \end{array}$		
B2	2NO+2NC	<i>Snap action, double pole</i>	
	$\begin{array}{c} 13 \quad 21 \quad 43 \quad 31 \\ \diagdown \quad \diagup \quad \diagdown \quad \diagup \\ 14 \quad 22 \quad 44 \quad 32 \end{array}$		

Plug and socket limit switches

All FR/FM/FZ/FX series limit switches can be converted to a plug-in style by the addition of an adaptor.

Part number
8R4D26E03C3003

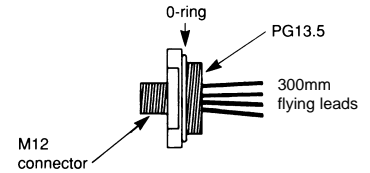

The adaptor is screwed into the limit switch and the four flying leads connected to the four terminals of the contact block.

Suitable 4-wire plug leads are available.

Ratings 250VAC/300VDC

3A

IP67

Cable glands

Cable glands are available to enable standard multi-core cables to be connected without the use of conduit.

Two sizes are possible:

Part number **VFPG13.5** Cable size \varnothing 9-12mm

Part number **VFPG13.5/6** Cable size \varnothing 6-9mm

