

SMR Series



- Up to 900 W Peak Output Power
- Single Outputs from 12 V to 48 V
- Compact Size
- Remote On/Off
- SEMI F47 Compliant
- Optional Current Share
- 3 Year Warranty

Specification

Input

Input Voltage	• 90-264 VAC (120-370 VDC)
Input Frequency	• 47-63 Hz
Input Current	• SMR600: 9 A at 90 VAC, 3.5 A at 230 VAC SMR800: 11 A at 90 VAC, 5 A at 230 VAC
Inrush Current	• 70 A at 230 VAC
Power Factor	• >0.9
Earth Leakage Current	• <2.4 mA max at 264 VAC
Input Protection	• Fitted with a T12 A/250 V fuse

Output

Output Voltage	• See table
Output Voltage Trim	• $\pm 5\%$
Initial Set Accuracy	• $\pm 1\%$
Minimum Load	• 1% (see note 9)
Start Up Delay	• 1.5 s at 230 VAC
Start Up Rise Time	• 40 ms typical
Hold Up Time	• 16 ms min at 120 VAC
Line Regulation	• $\pm 0.5\%$, low line to high line
Load Regulation	• $\pm 1\%$, 1-100% load (see note 8)
Over/Undershoot	• 5% max
Transient Response	• 5% max deviation, 500 μ s recovery to within 1% for a 50% load change
Ripple & Noise	• 1% of nominal output voltage (see note 2)
Overvoltage Protection	• 110-130% recycle input to reset
Overtemperature Protection	• Measured internally with auto recovery
Overload Protection	• 110-140% with auto recovery
Short Circuit Protection	• Trip and restart (Hiccup mode)
Remote Sense	• Compensates for up to 0.5 V line drop (not available with current share)
Remote On/Off	• On = TTL Logic HIGH, or open circuit Off = TTL Logic LOW or short circuit
Current Share	• Optional single wire current share within 10% for up to 4 units (add suffix '-I' to model number) Note that this option includes output blocking diodes. Remote sense is not available with current share.

General

Efficiency	• See model table
Isolation	• 3000 VAC Input to Output 1500 VAC Input to Ground 250 VDC Output to Ground
Switching Frequency	• 60 kHz PFC, 25 kHz PWM typical
Power Density	• SMR600: 6.16 W/In ³ , SMR800: 8.2 W/In ³
Signals	• Green LED for Power On, Power Good TTL HIGH within 100-500 ms and LOW ≤ 1 ms before loss of regulation
Current Monitor	• 0.5 V to 3 V output denoting 0-100% output current
MTBF	• 150 kHrs min to MIL-HDBK-217F at 25 °C, GB

Environmental

Operating Temperature	• 0 °C to +70 °C, derates from 100% load at +50 °C to 50% load at +70 °C
Cooling	• Integral fan
Operating Humidity	• 5-90%, non-condensing
Storage Temperature	• -20 °C to +85 °C
Operating Altitude	• 3000 m
Vibration	• 5-50 Hz, acceleration 7.35 ms ² on X, Y and Z axis

EMC & Safety

Emissions	• FCC Part 15 & EN55022, level B conducted and radiated
Harmonic Currents	• EN61000-3-2 class A EN61000-3-2 class C for loads $\geq 20\%$
Voltage Flicker	• EN61000-3-3
ESD Immunity	• EN61000-4-2, level 3 Perf Criteria A
Radiated Immunity	• EN61000-4-3, 3 V/m Perf Criteria A
EFT/Burst	• EN61000-4-4, level 2 Perf Criteria A
Surge	• EN61000-4-5, installation class 3 Perf Criteria A
Conducted Immunity	• EN61000-4-6, 3V Perf Criteria A
Dips & Interruptions	• EN61000-4-11, 30% 10 ms, 60% 100 ms, 100% 5000 ms Perf Criteria A, B, B
Safety Approvals	• UL60950, CSA C22.2 No. 950, EN60950-1:2001, CE Mark LVD, SEMI F47 compliant (high line only) at 100% rated power output

Models and Ratings

Output Power	Output Voltage ⁽⁷⁾	Output Current		Ripple & Noise ⁽²⁾	Efficiency		Model Number
		Maximum	Peak ⁽¹⁾		115 VAC	230 VAC	
600 W	12 V	50.00 A	75.00 A	120 mV	79%	83%	SMR600PS12
600 W	24 V	25.00 A	37.50 A	240 mV	80%	85%	SMR600PS24
600 W	48 V	12.50 A	18.75 A	480 mV	81%	86%	SMR600PS48
750 W	12 V	62.50 A	75.00 A	120 mV	79%	83%	SMR800PS12
800 W	24 V	33.33 A	37.50 A	240 mV	80%	85%	SMR800PS24
800 W	48 V	16.67 A	18.75 A	480 mV	81%	86%	SMR800PS48

Notes

1. Peak current can be taken for 500 μ s, average power should not exceed the maximum power.
2. Ripple & Noise is measured using 0.1 μ F ceramic and 22 μ F electrolytic capacitor, 20 MHz bandwidth.
3. Load regulation increases to 2% for 0-100% load change.
4. For Top Fan versions replace SMR with SMT. Contact sales for mechanical details.
5. For U-channel versions replace SMR with SMS. Contact sales for mechanical details
6. For output currents >50 A please use remote sense to meet load regulation ratings.
7. Other output voltages available in OEM quantities, please contact sales.
8. Minimum load required to meet ripple and noise specification.

Mechanical Details

Covered Version

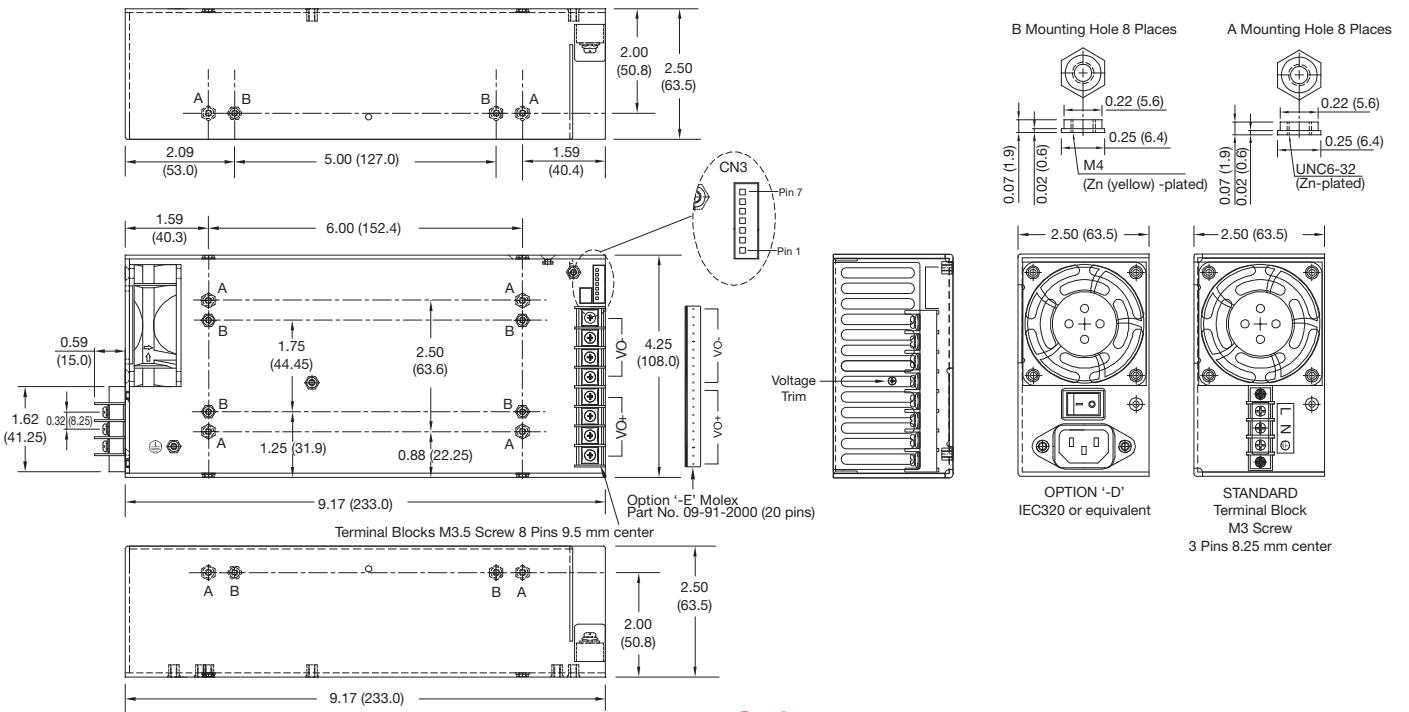

CN3 (Signals)	
Pin	Function
1	Current monitor
2*	Current share
3	Return
4	Power good
5	Remote On/Off
6*	-Remote sense
7*	+Remote sense

*If optional current share is fitted then remote sense function is excluded.

Options

Option	SMR	SMT	SMS
Current Share + output blocking diodes ⁽¹⁾	-I	-I	-I
Molex Output Connector ⁽¹⁾	-E	-E	-E
Molex Input Connector ⁽¹⁾		-F	-F
Molex Input Molex Output ⁽¹⁾		-G	-G
IEC320 Inlet	-D		
IEC Inlet Molex Outlet ⁽¹⁾	-F		

(1) Available for OEM quantities, contact Sales.
For multiple option codes, place codes in alphabetical order, e.g SMR800PS12-EI

Notes

1. All dimensions are in inches (mm).
2. Weight: 3.30 lbs (1.5 kg) approx.
3. Tolerance: ± 0.012 (± 0.3)
4. Logic connector CN3 mates with: JST XHP-7 or equivalent & JST SXH-002T-P0.6 crimp terminals.
5. Maximum mounting screw penetration: 0.12 (3.0) on base & 0.25 (6.3) on each side.
6. Maximum screw terminal torque: Output: 15.7 lbs-in (1.8 Nm) Input: 7 lbs-in (0.8 Nm)