

Position Sensor

Rotary

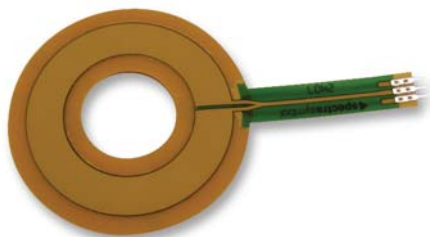

Specifications

Electrical Specifications	SoftPot
Resistance, standard	10k Ω (length >300mm 20k Ω)
Resistance range, customized	1k Ω to 100k Ω
Resistance tolerance	\pm 20%
Effective electrical travel	8 to 200mm
Linearity, independent	\pm 3% for linearity, \pm 5% for rotary
Power rating (depending on size) (varies with length and temperature)	1 Watt maximum at 25 $^{\circ}$ C
Resolution	Theoretical-Infinite; Resolution dependant on contact wiper thickness and construction
Dielectric value	No affect at 500V ac, 1 minute
Mechanical Specifications	
Live cycle (depending on viper)	>1 million
Height	typical \leq 0.51mm/0.020 inch
Actuation force (Actuation force increase approximately 30% for HP, EP) (No affect for SP)	-40 $^{\circ}$ C: 0.8 to 1.8N -25 $^{\circ}$ C: 0.8 to 1.8N -23 $^{\circ}$ C: 0.6 to 1.5N -75 $^{\circ}$ C: 0.5 to 1.4N
Environmental Specifications	
Operating temperature (with contact actuator)	-40 $^{\circ}$ C to +50 $^{\circ}$ C
Humidity	No affect at 95% RH, 4 hours <50 $^{\circ}$ C
Altitude	10,000 metres
IP Rating (Pot itself)	66
Shock	No closures >10msec at 100g half-sine on four sides
Vibration	No closure >10msec at 1hour random sine test

Position Sensor Rotary



Connection

Connections	Solder Tabs (upon on request housing and other connectors)
-------------	--

Individual options

Customized	Let us know your application, and we will help you design the optimum part
------------	--

Drawing (SoftPot)

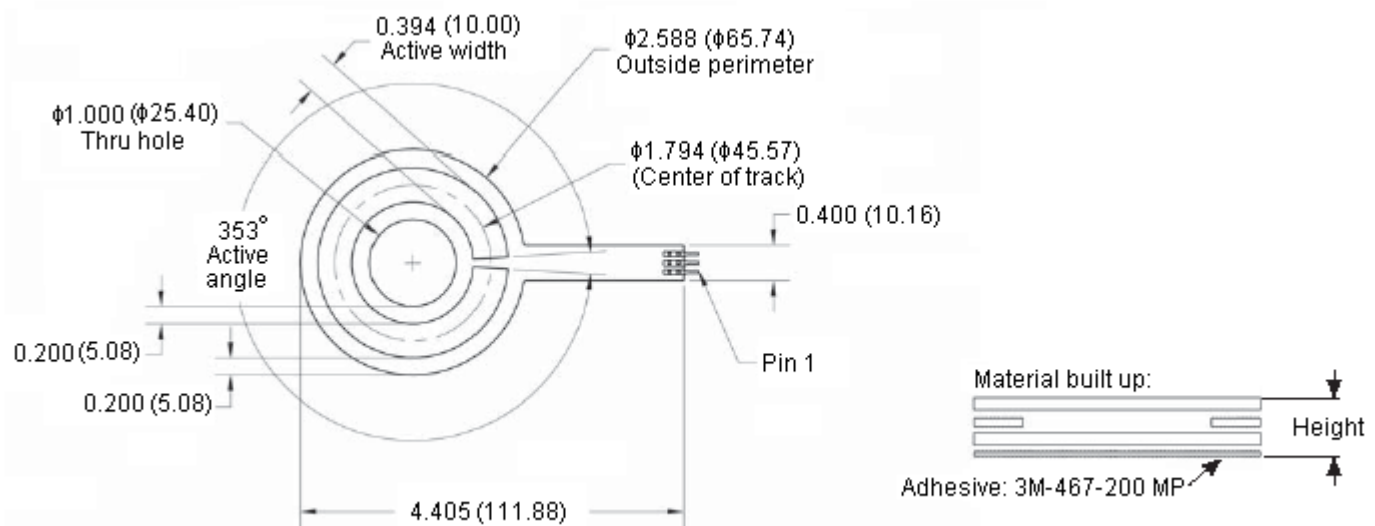

Dimensions: Millimetres (Inches)

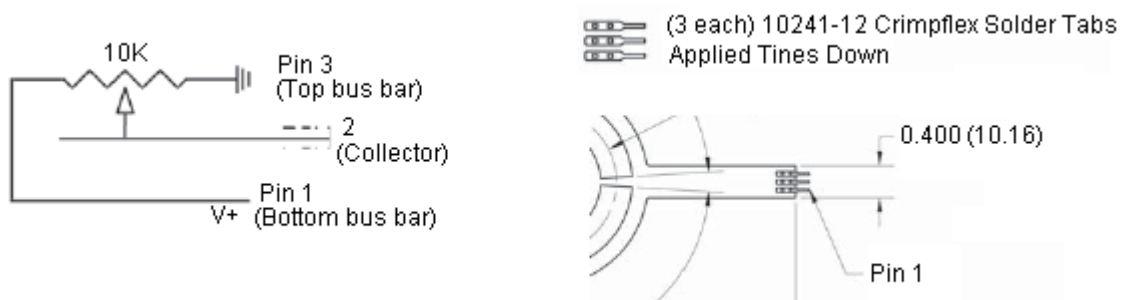

Part Number Table

Description	Part Number
Sensor, Linear, Membrane, Rotary	SP-R-0046/353-103-ST

Position Sensor

Rotary



Part Number Explanation:

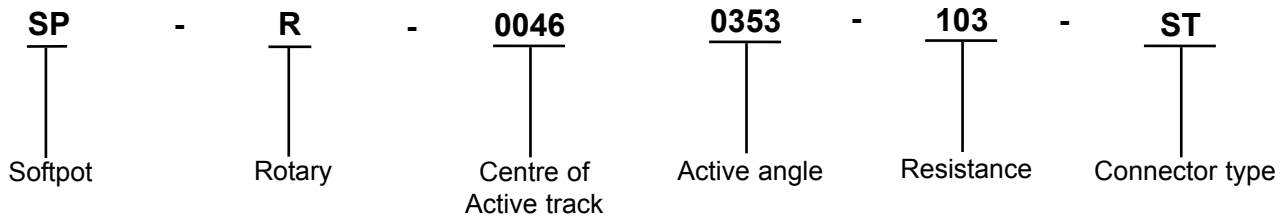

Centre of active track : 0046 = 45.57mm.
Active angle : 0353 = 353°.
Resistance : 103 = 10KΩ.
Connector type : ST = Solder tabs.

Disclaimer This data sheet and its contents (the "Information") belong to the Premier Farnell Group (the "Group") or are licensed to it. No licence is granted for the use of it other than for information purposes in connection with the products to which it relates. No licence of any intellectual property rights is granted. The Information is subject to change without notice and replaces all data sheets previously supplied. The Information supplied is believed to be accurate but the Group assumes no responsibility for its accuracy or completeness, any error in or omission from it or for any use made of it. Users of this data sheet should check for themselves the Information and the suitability of the products for their purpose and not make any assumptions based on information included or omitted. Liability for loss or damage resulting from any reliance on the Information or use of it (including liability resulting from negligence or where the Group was aware of the possibility of such loss or damage arising) is excluded. This will not operate to limit or restrict the Group's liability for death or personal injury resulting from its negligence. SPC Multicomp is the registered trademark of the Group. © Premier Farnell plc 2009.