

# Star-Delta Starters with Isolator Type EXE2SI

Metal Enclosure to IP65  
Installation Instructions

Issue 10

1. Remove cover from starter by releasing catches with a screwdriver.
2. Select overload: (see ratings / conversion charts below).
3. Connect leads provided from – Main Auxiliary 4 to Overload 95 and Main 5/L3 to Overload 96.
4. Check operating coil voltage and frequency.
5. Remove appropriate top/bottom knockouts.
6. Mount base on a vertical surface using top keyhole slots for quick positioning and secure with screws in lower plain holes.
7. To maintain environmental protection, ensure that rubber washers are fitted to fixing screws on outside of enclosure.  
Use large washer for keyhole fixing.
8. Connect conduit bushes.
9. Connect cables and ensure that all terminals are tight.
10. When installed, set the hand/auto reset selector and adjust the current calibration to the desired value.
11. Replace cover and secure catches.

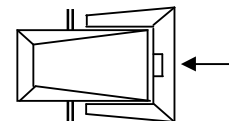

06.012230.10E.0808

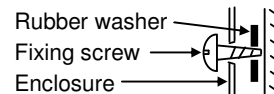

## Ratings

Starter Order references		Requires Overload	Overload rating Full load A		Approximate motor rating				Recommended max. fuse size for short circuit protection A
Coil Voltages (50Hz)			min.	max.	400V/3PH AC3		230V/3PH AC3		
230V	400V			KW	hp	KW	hp		
<b>312EXE2SI-OL</b> 1TVL405216E5099	<b>314EXE2SI-OL</b> 1TVL405416E5099	<b>TA25DU8.5</b> 1SAZ211201R1040	6.0	8.5	<b>5.5</b>	7.5	<b>3.0</b>	4.0	20
		<b>TA25DU14</b> 1SAZ211201R1045	10	14	<b>11</b>	15.0	<b>5.5</b>	7.5	35
		<b>TA25DU19</b> 1SAZ211201R1047	13	19	<b>15</b>	20.0	<b>7.5</b>	10.0	80
<b>452EXE2SI-OL</b> 1TVL405226E5099	<b>454EXE2SI-OL</b> 1TVL405426E5099	<b>TA25DU32</b> 1SAZ211201R1053	24	32	<b>22</b>	30.0	<b>11.0</b>	15.0	80

Note: This product is not suitable for d.c. applications.

## Terminal capacity

Isolator	Main
All ratings	0.75...10mm <sup>2</sup>

Overload	Main	Auxiliary
< 7.5kW	4mm <sup>2</sup>	1x4mm <sup>2</sup> / 2x2.5mm <sup>2</sup>
11kW	4mm <sup>2</sup>	" "
15kW	6mm <sup>2</sup>	" "
22kW	6mm <sup>2</sup>	" "

## Trip class requirements IEC 947-4-1

<b>1.05 x FLC</b>	No tripping
<b>1.2 x FLC</b>	Trip within 2 hours
<b>1.5 x FLC</b>	Trip within 4 minutes
<b>7.2 x FLC</b>	Trip between 4s and 10s

**NOTE:** FLC = Full load current

## Summary

A range of star-delta motor starters with isolator  
Ingress protection to IP65.  
Painted steel enclosure.

**N.B.** Space is available to fit standard ABB top  
and side mounted auxiliary contacts.

## Connection Data

Type 4 EXE2SI (400Vcoil)

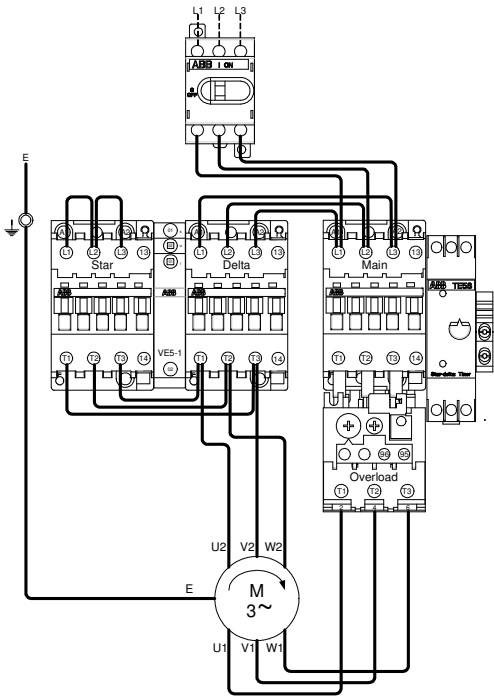

Type 2 EXE2SI (230V coil)

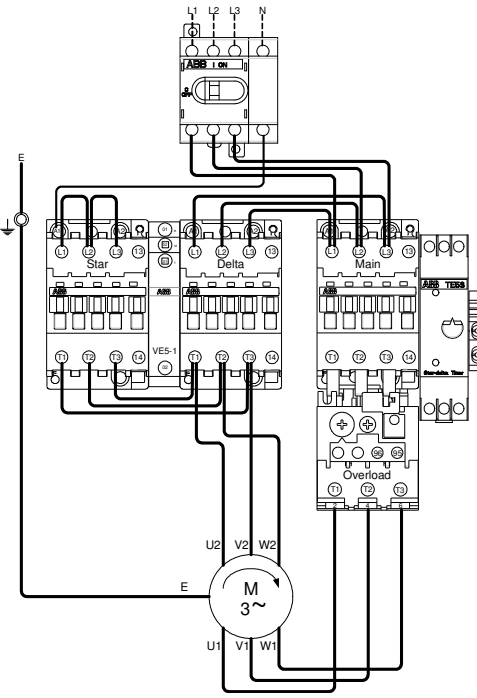

## Conversion Chart

Motor full load current A	Overload setting Delta loop current A
5	2.9
6	3.5
7	4.0
8	4.6
9	5.2
10	5.8
12	7.0
14	8.1
16	9.3
18	10.4
20	11.6
25	14.5
30	17.4
35	20.3
40	23.2
45	26.1
50	29.0
55	32.0

Note : Overload relay is fitted in the delta loop. It is therefore necessary to use the conversion chart to obtain correct overload setting for a particular motor full load current.

## Circuit

Star-Delta  
(main contactor in Delta loop)

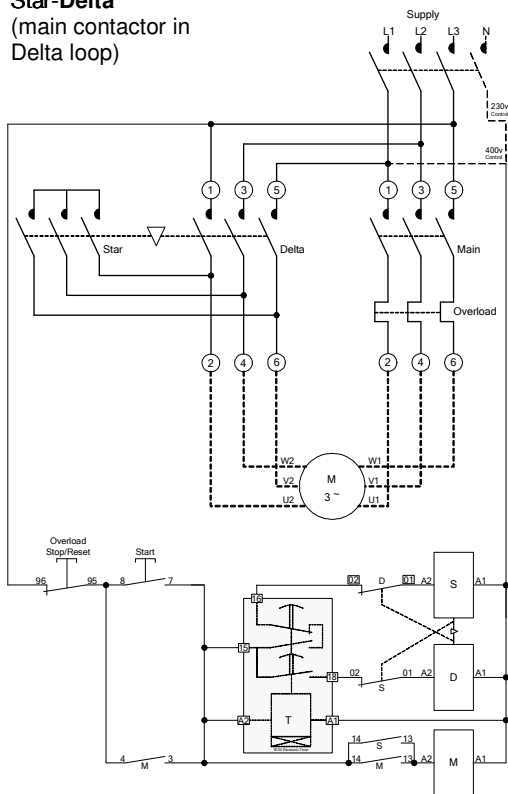

## Modification for remote 2-wire control

Overload should be in hand reset. Stop reset button will only stop motor whilst button is depressed, if pressure switch is closed.

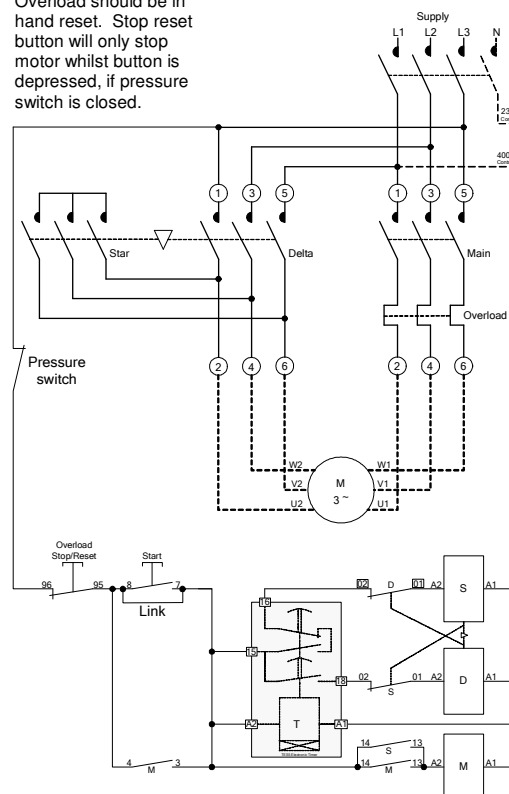

**Council of European Communities Directives:** The products in this publication conform to relevant EEC Directives and EN Standards. Installation and use of such products must be carried out by competent, properly trained personnel, complying with any instructions supplied by ABB. Liability for improper incorporation, assembly, use, processing, storing or handling of goods remains the sole responsibility of the individual, or company carrying out such work. This publication is for information only. Whilst every care has been taken in the preparation of this leaflet, no liability is accepted for any consequence of its use. No licence to use any patent should be assumed. All dimensions are approximate only and subject to change without notice, as are other technical features resulting from continual development and improvement.