

取付穴寸法図 MOUNTING HOLE DETAIL
(挿入側より) (VIEWED FROM MOUNTING SIDE)

L: LUG TERMINAL ラグ端子とする

- NOTES
1. MOUNTING SCREW THREAD LENGTH IS CHASSIS THICKNESS + 2mm MAX.
取付用ネジの首下長さは、シャーシ板厚 + 2mm 以下とする。
 2. TOP SIDE OF KNOB SHALL BE MOUNTED TO LEVER WITHIN 30mm LENGTH FROM LEVER MTG. SURFACE.
取付面からツマミ先端まで 30mm 以内でご使用願います。

指定なき部分の許容差 TOLERANCES UNLESS OTHERWISE SPEC	
$L \leq 10$	± 0.3
$10 < L < 100$	± 0.5
$100 \leq L$	± 0.8
角度 ANGULAR DIMENSION	$\pm 5^\circ$

PART NO.	NAME	MATERIAL NAME / CODE	FINISH
ALPS ELECTRIC CO., LTD.			
		DSGD. セツケイ K. SATOU '96-06-16	SCALE 1:1
		CHKD. S. ABE '93-06-16	TITLE SLIDE POTENTIOMETER SINGLE UNIT
		APPD. Y. YOSHIOKA '93-06-16	UNIT DOCUMENT NO.
SYMB	DATE	APPD	CHKD

ご使用上の注意
PRECAUTION IN USE

1. 偏心ツマミをご使用になる場合

レハ-の中心より離れたところを作用点としてご使用になる場合、可能な限り
 下図A寸法を短くしてご使用下さい。

If it will be used the operating point away from the center line of the lever, it should be shorter as possible.

2. レハ-長さについて

レハ-長さについては、ツマミを含めて、下図B面より極力短いものをご使用願います。レハ-長さについては、作用点までの距離が短いほどしゅう動感が良好となり、長いほど好ましくない感になります。

About the length of lever

If conditions permit, it is advisable to use the shortest possible lever.

The longer the length up to operating point, the more unfavorable slide feeling will be given.

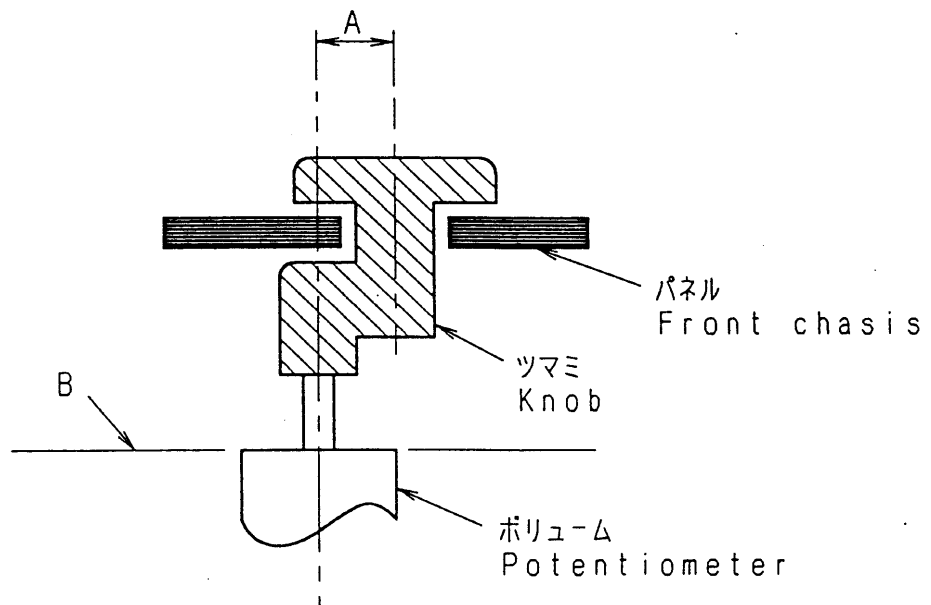

3. レハ-の駆動に関しては上記内容を考慮の上、セット実装を行い
 あらかじめ異常のないことをご確認願います。

Regarding the operation of the lever, please consider the above mentioned, and make sure nothing is wrong with the operation under installing in your appliance that you plan to use our products actually.

4. ツマミ挿入及びレハ-操作は、ポリウムマウント基板に
 ソリ(曲がり)のない状態で行って下さい。

Knob assembly on the lever and functioning the lever to be performed under the condition of P. C. B. without warp.

					ALPS ALPS ELECTRIC CO., LTD.					
					APPD.	CHKD.	DSGD.	TITLE		
					(PDI-ENGI) '95.7.24 YOSIOKA	(PDI-ENGI) '95.7.24 KIMURA	(PDI-ENGI) '95.7.24 Y. SAITOH	スライト・ポリウム 仕様書 SPECIFICATIONS		
ORIGINAL	'91-7-3	Y·Y	K·N	S·A	DOCUMENT NO.					
SYMB	DATE	APPD	CHKD	DSGD	4S0001-200					
					G0447764M					

はんだ付け条件

FOLLOW THE NEXT CONDITIONS FOR SOLDERING

1. はんだ SOLDER

JIS Z 3282に規定の63% Snはんだを使用
63% Sn solder specified in JIS Z 3282.

2. 使用基板 BOARD IN USE

両面スルーホール基板又は、片面銅張積層板 板厚 $t=1.6\text{mm}$
Double-faces through-hole board or Single-face copper laid laminate board.
Plate thickness (t) = 1.6mm

3. 自動はんだ<DIP条件>

- (1) レベル位置 センター付近に設定願います。
- (2) フラックス比重 0.83 ± 0.01 (発泡式)
- (3) フラックス高さ フォトリソ基板の板厚の半分の位置にフラックスの上面が接するレベル (図1)
又、ホリウム挿入面への流れ込みのないこと。(フラックス上がり、飛散に注意)
- (4) フォリヒート温度 100°C max. 時間1分以内。(フォリソ基板のホリウム挿入側の温度)
- (5) はんだ温度 260°C max. 時間5秒以内。 はんだ回数は1回までとする。

IN THE CASE OF DIP SOLDERING

- (1) State of potentiometer
Position a lever in the vicinity of center.
- (2) Specific Gravity of Flux
 0.83 ± 0.01 (foaming type)
- (3) Height of Flux face
A level of the upper face of flux for reaching the position at a half of the plate thickness of printed board. (Fig. 1)
Further, no flow of flux invading on the surface of printed board on the side of installing potentiometer is allowed.
- (4) Preheat condition
 100°C max., within 1 minute
(Temperature on the side of installing printed board is designated.)
- (5) Soldering condition
Solder temperature: 260°C max.
Soldering period : within 5 seconds
Time of soldering : only one time is permitted

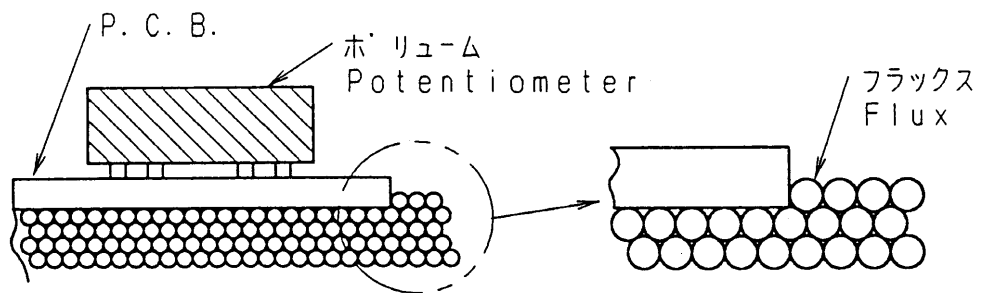

(Fig. 1)

4. 手はんだ IN THE CASE OF MANUAL SOLDERING

はんだ温度 300°C max. 時間3秒以内 はんだ回数は1回までとする。
Solder temperature : 300°C max.
Soldering period : within 3 seconds
Time of soldering : only one time is permitted

					ALPS ALPS ELECTRIC CO., LTD.				
					APPD.	CHKD.	DSGD.	TITLE スライドホリウム仕様書 SPECIFICATIONS 1/2	
					PDI-ENGI '95.7.24 YOSIOKA	PDI-ENGI '95.7.24 KIMURA	PDI-ENGI '95.7.24 Y. SAITOH	DOCUMENT NO. 450001-201	
ORIGINAL	'91-9-3	Y·Y	S·A	S·S					
SYMB	DATE	APPD	CHKD	DSGD					

5. 注意事項

- (1) はんだ付けの際に、端子にストレスを加えないで下さい。例えば、端子に熱を加えたまま製品を動かしますと、かしめ力^{*}タ及び電気的特性が劣化する恐れがあります。
- (2) 両面スルーホール基板を使用する場合は、ホ^{*}リウム挿入側の端子取付穴に、はんだランド^{*}がないようにご配慮願います。ホ^{*}リウム挿入側での配線が必要な場合は端子取付穴からの直接取り出しを避けスルーホール配線用の穴を設けるなどのご配慮をお願いします。
- (3) ホ^{*}リウム挿入側へのはんだ上がりは、はんだ熱による端子接触不良の発生原因となりますので(図2)を参照願います。
- (4) リート^{*}配線の場合、ホ^{*}リウム本体と、はんだ付け部の距離を1mm以上開けてはんだ付け願います。(図3)
- (5) はんだ付けによるホ^{*}リウムへの影響は、フ^{*}リント基板の大きさ、ホ^{*}リウムの取付け位置、はんだ槽の大きさ、等により異なりますのであらかじめ実使用状態で実施し、異常のないことを確認の上、はんだ付けして下さい。

MATTERS TO BE NOTED

- (1) Do not add any stress on terminals in the case of soldering. For instance, forced movement of potentiometer with terminals being heated may probably deteriorate the electric features due to generation of looseness in connection between resistant board and terminals.
- (2) Avoid use of double-faces through-hole board as much as possible. If it is necessary to use it, do not apply through-hole plating to a hole in which a potentiometer is inserted, and install a land to which terminals are soldered only on a face opposite to the face on the side of installing potentiometer.
- (3) Use caution to soldering process so as to prevent solder from rising up to the surface of printed board on the side of installing potentiometer, because defective contact may take place in terminal connecting part due to soldering heat. (Fig. 2)
- (4) In the case of lead wiring, solder it so that a gap of 1 mm or more may be reserved between the potentiometer body and soldering part. (Fig. 3)
- (5) The grade of influence of soldering exerted on the potentiometer depends upon the size of a printed board, installing position of the potentiometer, and the size of a solder bath etc. Therefore, make sure, in advance, of no abnormal state under the conditions of soldering to be carried out at present.

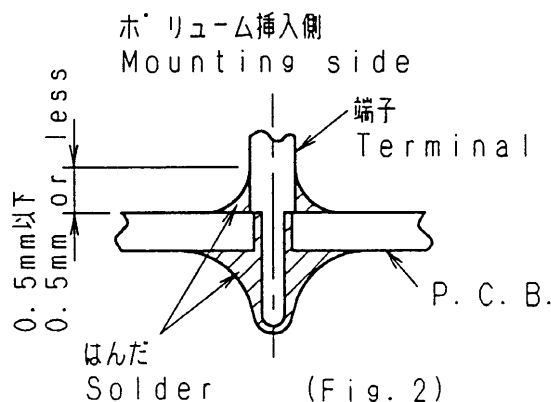

(Fig. 2)

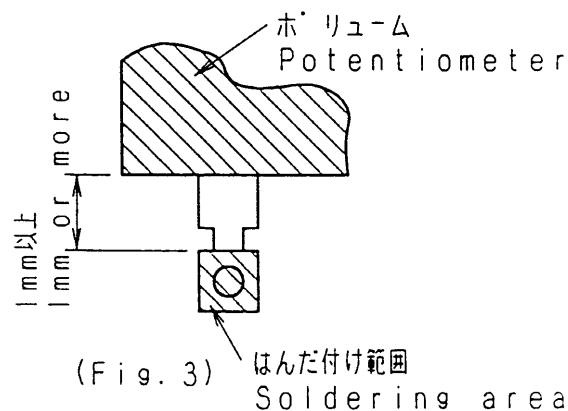

(Fig. 3)

					ALPS ALPS ELECTRIC CO., LTD.				
					APPD.	CHKD.	DSGD.	TITLE	
					(PDI-ENGI) '95.7.24 YOSIOKA	(PDI-ENGI) '95.7.24 KIMURA	(PDI-ENGI) '95.7.24 Y. SAITOH	スライドホリウム仕様書 SPECIFICATIONS 2/2	
ORIGINAL	'91-9-3	Y·Y	S·A	S·S	DOCUMENT NO.				
SYMB	DATE	APPD	CHKD	DSGD	4S0001-201				

SPECIFICATIONS

1. THIS SPECIFICATIONS APPLY TO RS6011Y14 POTENTIOMETERS.

2. CONTENTS OF THIS SPECIFICATIONS.

4S6028N-302M, 4S0008-45M
4S0001-200, 4S0001-201
S6028N404A

3. MARKING

· MARKING ON ALL UNITS
DATE CODE, RESIST. VALUE, TAPER, TRADE MARK

Marking → in specifications shows
standard and condition for application

CLASSNO. TITLE STANDARD TYPE POTENTIOMETER (SLIDE)

ELECTRICAL

1. Overall resistance :
Overall resistance tolerances : $\pm 20\%$ Unit : K Ω

5	10	20	50	100	200	250	500	1,000
---	----	----	----	-----	-----	-----	-----	-------

2. Minimum resistance : Unit : Ω

Overall resistance (K Ω)	5,10	20,50	100	200,	500	1000
	30	50	100	200	300	500
Across term.1-2	30	50	70	120	220	320
Across term.2-3	50	70	120	220	320	500

3. Taper : ALPS "B" (SBS50)

4. Rated power : 0.2 Watts.

5. Rated voltage : Rated voltage = $\sqrt{P \cdot R}$ (V)

P : rated power (W)

R : nominal overall resistance (Ω)

When the rated voltage exceeds the maximum operating voltage the maximum operating voltage shall be the rated voltage.

Maximum operating voltage : A.C.200V , D.C. 10 V

6. Dielectric test : Units shall be designed to withstand 300 volts A.C. 50 Hz R.M.S. between resistance elements and case for a period of one minute without damage or arcing.

7. Insulation resistance : Greater than 100 megohms between resistance elements and case when tested by a 250 volts D.C. insulation resistance meter.

8. Sliding lifetest : 15,000 cycles

- Lever shall be operable with speed of 20 mm per sec. without noise by static electricity.

DATE	APPR	CHKD.	DSCD.	TITLE SPECIFICATIONS	
				ALPS ELECTRIC CO., LTD.	
				DOCUMENT NO.	
				4S6028N-302M	

15-112

USED ON	NAME
60 TRAVEL TYPE	RESISTANCE TAPER
ALPS ELECTRIC CO., LTD.	TITLE
1-7 YUKIGAYA OTSUKA-CHO	SPECIFICATIONS
OTA-KU TOKYO JAPAN	

TAPERED CURVE: ALPS "B"

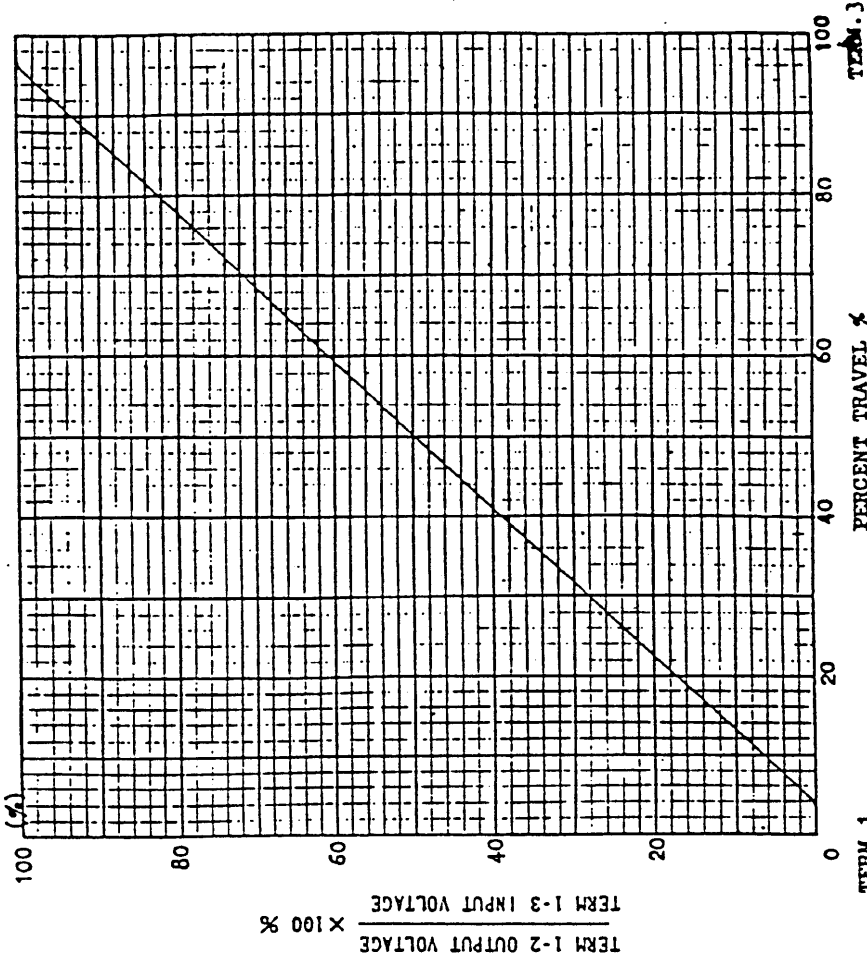

TERM. 1

NOTES: PERCENT VOLTAGE CHECK POINT

TOLERANCE

50% TRAVEL FROM TERM.1 40 - 60 %

DATE	APPR.	CHKD.	DSCD.	HAKE
				RESISTANCE TAPER
				DWG. NO. SBS50

1011

CLASS.NO.

TITLE
STANDARD TYPE POTENTIOMETER (SLIDE)

MECHANICAL

1. Travel : Specified in particular Figure.
2. Operating force : 30-250 gf (Note 1)
3. Starting force : Operating force + 100 gf max. (Note 1)

(Note 1) Measuring temperature : 5°C - 35°C

Measuring point :

- : 5 mm from lever end (Lever length > 6 mm)
- : 1 mm from lever end (Lever length ≤ 6 mm)
- Sliding speed : 20 mm per sec.

4. Stop strength :

- 5 kgf at a position 5 mm from mounting surface.
(Lever length > 6 mm)
- 5 kgf at a position 2 mm from mounting surface.
(Lever length ≤ 6 mm)

5. Lever lateral play :

When an alternating bending moment of 250 gf.cm is applied perpendicular to the direction of lever travel, the bothside movement of the lever shall be less than 2 (2 X L / 20) mm
L: Lever length on the measurement point from mtg. surface.
(Note 2) Exempt warping of insulated lever.

Lever lateral play



M = 250 gf.cm

$L \leq 5$ mm
The bothside movement of the lever shall be less than 1.2 mm

6. Lever strength :

- (1) To be resistant with 5 kgf static force of pull or push applied to lever in thrust direction for 10 seconds without damage.

CLASS.NO.	TITLE	ALPS ELECTRIC CO., LTD.		TITLE	SPECIFICATIONS	
		APPD.	CHKD.	DISCD.		
		App. + 9/1		App. 3/91	Doc. No.	4 S 0 0 8 - 4 5 M (1/2)
DATE	APP.	CHKD.	DISCD.	DATE	APP.	CHKD.

CLASS.NO.

TITLE
STANDARD TYPE POTENTIOMETER (SLIDE)

- (2) To be resistant with following static force applied to lever in vertical direction to lever driving for 10 seconds without damage.

- ① 2 kgf.cm over : in case of pot., mounted to chassis with screws.
- ② 0.5 kgf.cm over : in case of pot., mounted to P.C.B. only with terminals.
- ③ 2 kgf.cm over : in case of pot., mounted to P.C.B. with both terminals and mounting plate.

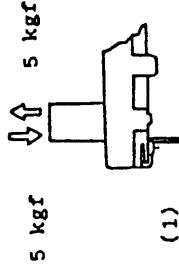

(1)

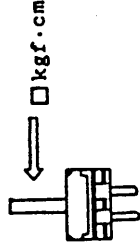

(2)

7. Lever inclination and twist :

Twist



Inclination

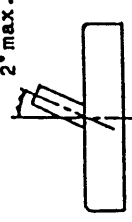

Inclination

2° max.

8. Resistance to soldering heat : 3 sec. max. at 300°C

CLASS.NO.	TITLE	ALPS ELECTRIC CO., LTD.		TITLE	SPECIFICATIONS	
		APPD.	CHKD.	DISCD.		
		App. + 9/1		App. 3/91	Doc. No.	4 S 0 0 8 - 4 5 M (2/2)
DATE	APP.	CHKD.	DISCD.	DATE	APP.	CHKD.