

**ENERGIZER 373**

**SILVER OXIDE**

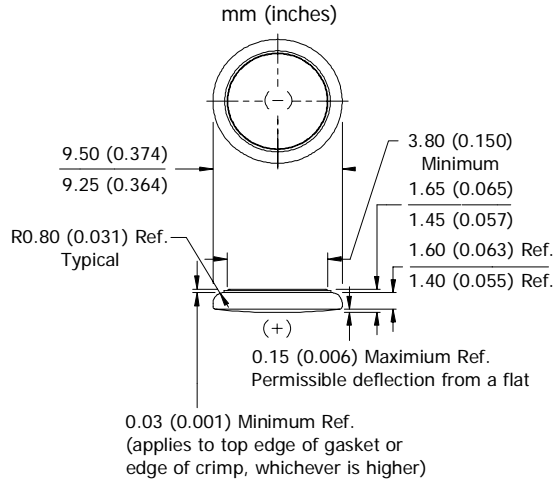

**Industry Standard Dimensions**



DESIGNED FOR USE ON CONTINUOUS LOW DRAIN

**Specifications**

<b>Chemical System:</b>	Silver Oxide (Zn/Ag <sub>2</sub> O)
<b>Designation:</b>	IEC-SR68
<b>Nominal Voltage:</b>	1.55 Volts
<b>Typical Capacity:</b>	30 mAh* (to 1.3 volts)
<b>Capacity Test:</b>	30K ohm continuous drain at 21°C
<b>Typical Weight:</b>	0.50 grams (0.016 oz.)
<b>Typical Volume:</b>	0.12 cubic centimeters (0.007 cubic inch)
<b>Impedance (40 Hz):</b>	40 to 50 ohms

\* Varies according to the applied load, temperature, and cutoff voltage.

**Cross Section**

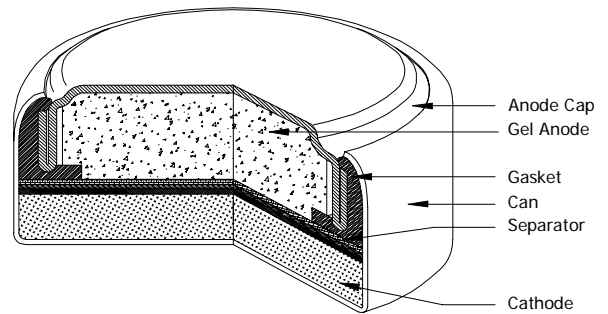

**Typical Discharge Characteristics**

Typical Performance at 21°C (70°F)

**Schedule:** Continuous  
**Typical Drain @1.55V:**  
0.052 milliamperes  
**Load:** 30K ohm

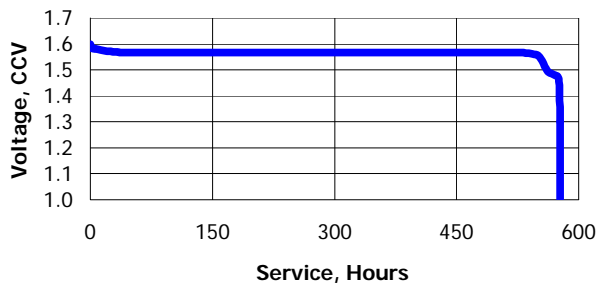

<u>Schedule</u>	<u>Typical Drains</u> at 1.55V (milliamperes)	<u>Load</u> (ohm)	<u>Cutoff</u> 1.3V (hours)
Continuous	0.052	30K	577

**Temperature Characteristics**

Typical Performance at Low Discharge Rates

**Service Effects**

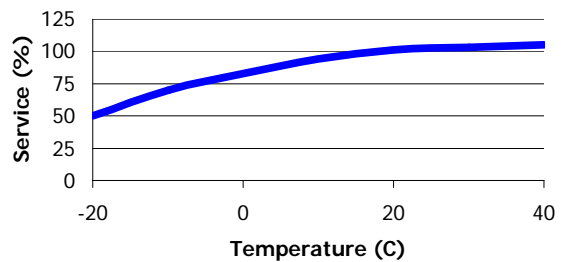

**Storage Effects**

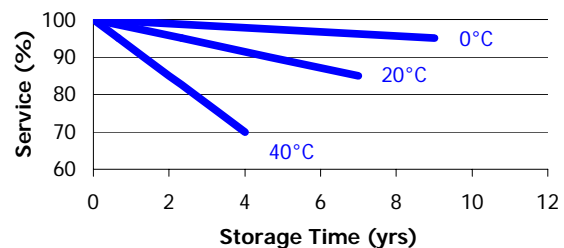

**Important Notice**

This datasheet contains typical information specific to products manufactured at the time of its publication.

©Energizer Holdings, Inc. - Contents herein do not constitute a warranty.