

REVISIONS

ISSUE	CHANGES
2	CN 27545 C SD 8 NOV 85

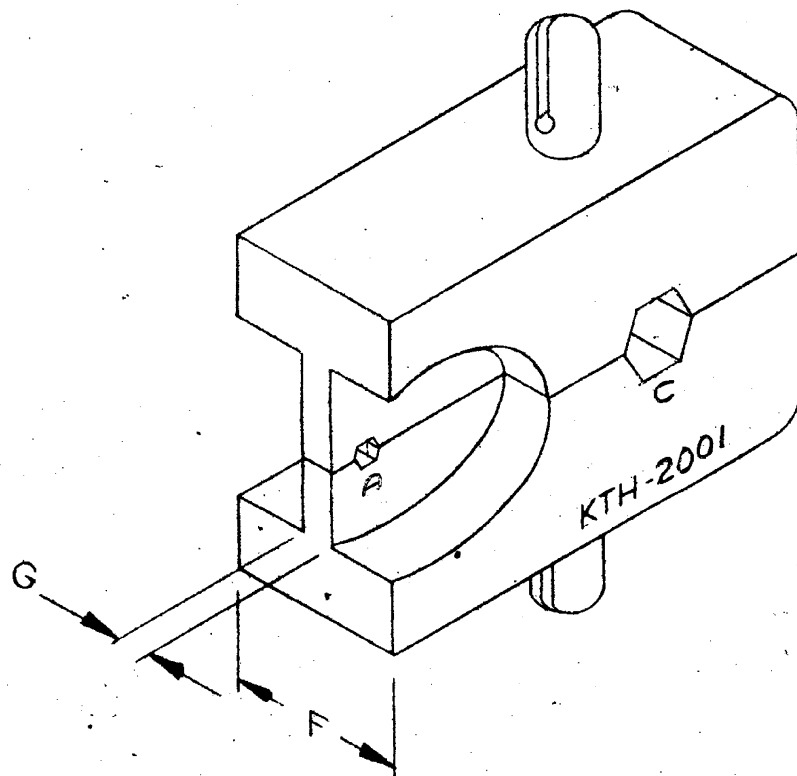

NOTES:

- FOR USE WITH RG-55, 58, 141, 142, 223 & ITT BA 13077A CABLE GROUPS.
- MATERIAL: ALLOY STEEL; FINISH: BLACK OXIDE

HEX SIZES (ACROSS FLATS)				DIE WIDTH	WEB WIDTH			
A	B	C	D	F	G	H	I	
.069	—	.213	—	.400	.080	—	—	

064

UNLESS OTHERWISE SPECIFIED:

- TOLERANCES: FRACTIONS & 2 PLACE DECIMALS $\pm .010$
3 PLACE DECIMALS $\pm .004$ ANGLES $\pm 0^\circ 30'$
- REMOVE ALL BURRS, BREAK SHARP EDGES .005 MAX.
- NO FILLETS PERMITTED.
- SURFACE ROUGHNESS 63 MICROINCHES RMS MAX.
- ALL DIMENSIONS PRIOR TO PLATING.

REF:
FINISH
SPEC.
MATL.
SPEC
CRIMP DIE
DRAWN JGL. DATE 15 JUN 72
APPR. DATE

KINGS ELECTRONICS
40 MARBLEDALE ROAD
TUCKAHOE, N. Y. 10707

KTH-2001

CS