

PART NO.	ENG. NO.	MAT'L.	PLATE	WIRE GAGE	DIM. "B"	DIM. "C"	DIM. "D"	DIM. "E"	DIM. "F"	DIM. "G"		
39-00-0207	5556-SP	A	A	18-24 GA.	.142±.012 (3.60±0.30)	.177±.016 (4.50±0.40)	.035 (0.90)	.075±.012 (1.90±0.30)	.091±.016 (2.40±0.40)	.020 (0.50)		
39-00-0208	5556-SPL			22-28 GA.	.091±.012 (2.30±0.30)	.091±.016 (2.30±0.40)	.024 (0.60)	.071±.012 (1.80±0.30)	.065±.016 (1.65±0.40)	.016 (0.40)		
39-00-0209	5556-S2P			16 GA.	.142±.012 (3.60±0.30)	.177±.016 (4.50±0.30)	.035 (0.90)	.091±.012 (2.30±0.30)	.106±.016 (2.70±0.40)	.024 (0.60)		
39-00-0210	5556-S2PL			B	A	18-24 GA.	.142±.012 (3.60±0.30)	.177±.016 (4.50±0.40)	.035 (0.90)	.075±.012 (1.90±0.30)	.091±.016 (2.40±0.40)	.020 (0.50)
39-00-0211	5556-S3P					22-28 GA.	.091±.012 (2.30±0.30)	.091±.016 (2.30±0.40)	.024 (0.60)	.071±.012 (1.80±0.30)	.065±.016 (1.65±0.40)	.016 (0.40)
39-00-0212	5556-S3PL					16 GA.	.142±.012 (3.60±0.30)	.177±.016 (4.50±0.30)	.035 (0.90)	.091±.012 (2.30±0.30)	.106±.016 (2.70±0.40)	.024 (0.60)
39-00-0213	5556-PBSP	B	A			18-24 GA.	.142±.012 (3.60±0.30)	.177±.016 (4.50±0.40)	.035 (0.90)	.075±.012 (1.90±0.30)	.091±.016 (2.40±0.40)	.020 (0.50)
39-00-0214	5556-PBSPL					22-28 GA.	.091±.012 (2.30±0.30)	.091±.016 (2.30±0.40)	.024 (0.60)	.071±.012 (1.80±0.30)	.065±.016 (1.65±0.40)	.016 (0.40)
39-00-0215	5556-PBS2P					16 GA.	.142±.012 (3.60±0.30)	.177±.016 (4.50±0.30)	.035 (0.90)	.091±.012 (2.30±0.30)	.106±.016 (2.70±0.40)	.024 (0.60)
39-00-0216	5556-PBS2PL			B	A	18-24 GA.	.142±.012 (3.60±0.30)	.177±.016 (4.50±0.40)	.035 (0.90)	.075±.012 (1.90±0.30)	.091±.016 (2.40±0.40)	.020 (0.50)
39-00-0217	5556-PBS3P					22-28 GA.	.091±.012 (2.30±0.30)	.091±.016 (2.30±0.40)	.024 (0.60)	.071±.012 (1.80±0.30)	.065±.016 (1.65±0.40)	.016 (0.40)
39-00-0218	5556-PBS3PL					16 GA.	.142±.012 (3.60±0.30)	.177±.016 (4.50±0.30)	.035 (0.90)	.091±.012 (2.30±0.30)	.106±.016 (2.70±0.40)	.024 (0.60)

LEGEND:

5556 - ** S * P *

BASE NO. _____

MATERIAL _____

BLANK= BRASS

PB= PHOS. BRONZE

S= TIN OVER NICKEL

PLATING & CRIMP SIZE COMB. _____

BLANK THRU 5

CHAIN OR LOOSE _____

BLANK= CHAIN

L= LOOSE

NOTES

- MATERIAL:
A= BRASS
B= PHOS. BRONZE
- FINISH:
A= .000100/(.00254) MIN BRIGHT TIN OVER .000050/(.00127)MIN. NICKEL
- PRODUCT SPECIFICATION: PS-5556-001, PS-5556-002, PS-5556-003.
- PACKAGING SPECIFICATION: PK-5556-001 FOR CHAIN TERMINALS
PK-5556-003 FOR LOOSE TERMINALS.
- MATES WITH: 5558, 5566, 5569, 30069, 30070, 42440, 42404, 43879, 43810, 44068.
- APPLICABLE HOUSINGS: 5557, 30067, 43760, 44516, OR 42474.
- THE NUMBER OF SERRATIONS TO BE ONE FOR WIRE RANGE #22-28.
- WHEN TERMINALS ARE INSTALLED IN THE HOUSING THE WIRES ARE TO BE DRESSED IN SUCH A MANNER TO ALLOW THE TERMINALS TO FLOAT FREELY IN THE POCKET.
- THIS TERMINAL IS DESIGNED FOR SINGLE WIRE CRIMPING.
- PART CONFORMS TO CLASS "B" REQUIREMENTS OF COSMETIC SPECIFICATION PS-45499-002.

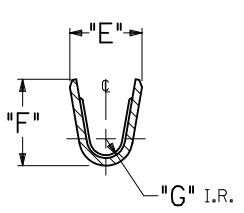
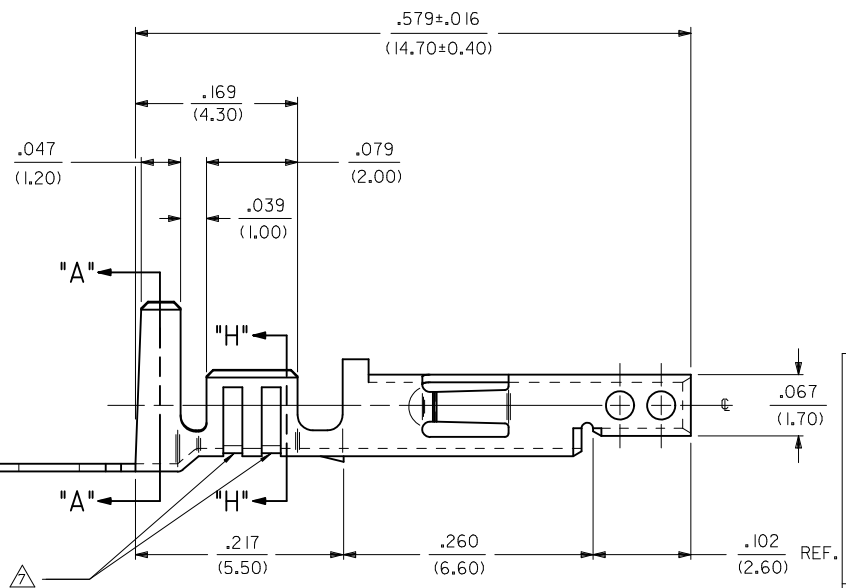
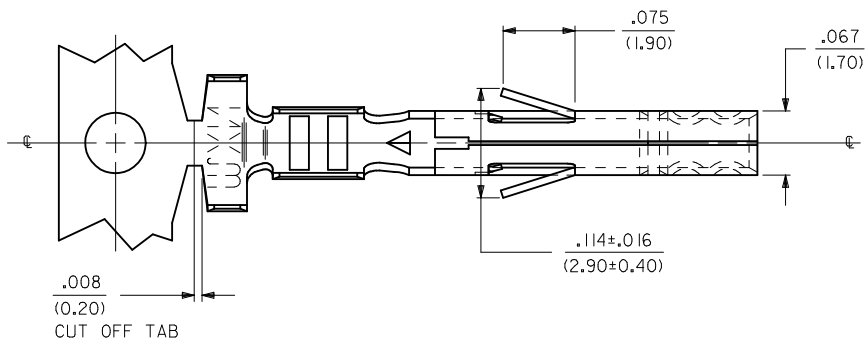

SECT. "H-H"

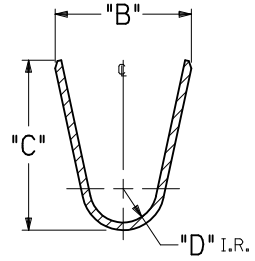

SECT. "A-A"

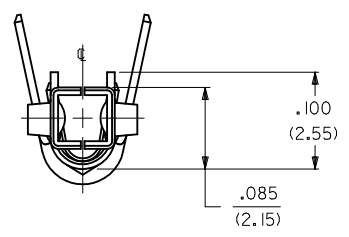

REMOVE 28-30 GA EC NO: UCP2012-0055 DRW: NGUYEN 2011/07/18 CHKD: J.BELL 2011/07/18 APPR: F.S.MITH 2011/07/20	QUALITY SYMBOLS ∇=0 ∇=0 ∇=0	GENERAL TOLERANCES (UNLESS SPECIFIED)		DIMENSION STYLE IN/MM		SCALE 10:1	DESIGN UNITS INCH	THIRD ANGLE PROJECTION		
		mm	INCH	DRAWN BY	DATE	TITLE MINI FIT JR OVERALL BRIGHT TIN OVER NICKEL FEMALE CRIMP TERMINAL				
		4 PLACES ± --- ± ---	3 PLACES ± --- ± .010	2 PLACES ± 0.25 ± .014	1 PLACE ± 0.36 ± ---	APPROVED BY RAS	DATE 5/17/1990	MOLEX INCORPORATED		
		ANGULAR ±1/2°		MATERIAL NO. SEE CHART		DOCUMENT NO. SD-5556-SP*		SHEET NO. 1 OF 1		
DRAFT WHERE APPLICABLE MUST REMAIN WITHIN DIMENSIONS				THIS DRAWING CONTAINS INFORMATION THAT IS PROPRIETARY TO MOLEX INCORPORATED AND SHOULD NOT BE USED WITHOUT WRITTEN PERMISSION						