

Art.-Number: 701108

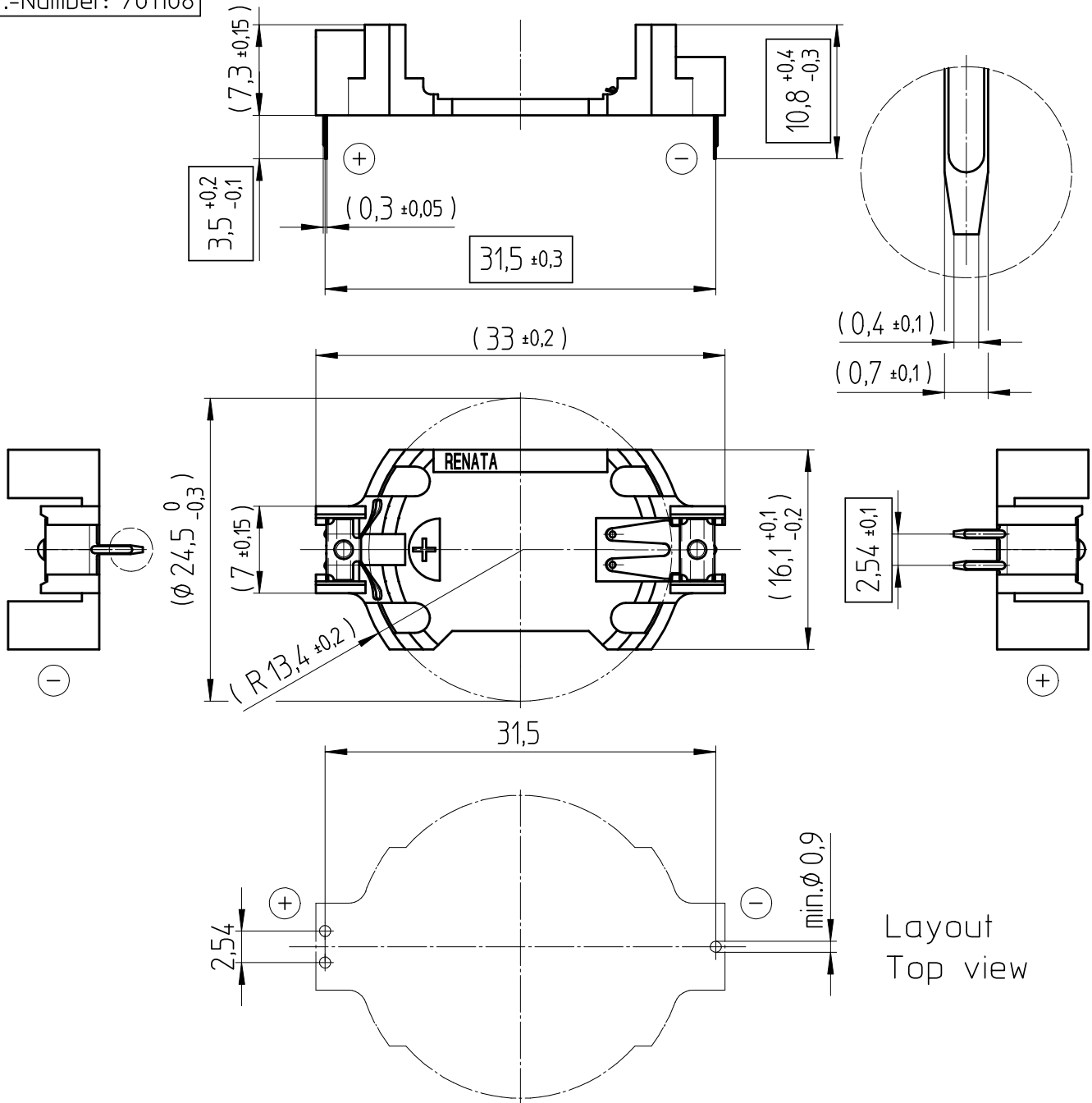

- Samples can deviate in the execution from the serie.

- Dimensions and tolerances can be specified only after the testing of the devices for the mass production definitely

Holder material : heat resistant, glass-fiber reinforced LCP

Battery contacts : spring stainless steel 301 nickel plated, thickness 10µm

Solder contacts : spring stainless steel 301 solder plated throughout 100% Sn, thickness 10µm

All framed values will be used for dimension checking !

Rev.	①	10.09.07	MCI	Rev.	○			Customer's Approval			
Rev.	○			Rev.	○			Date			
Rev.	○			Rev.	○			Signature			
Titel:							Scale 2:1	Drawn	21.01.05	SRI	
HU2450N-LF								Checked	10.09.07	BBö	
								Approved			
							CH-4452 Itingen Switzerland		3.8753.4-1		