

REVISIONS

ISSUE	CHANGES
	CN 27547 C AJ 2 DEC 85

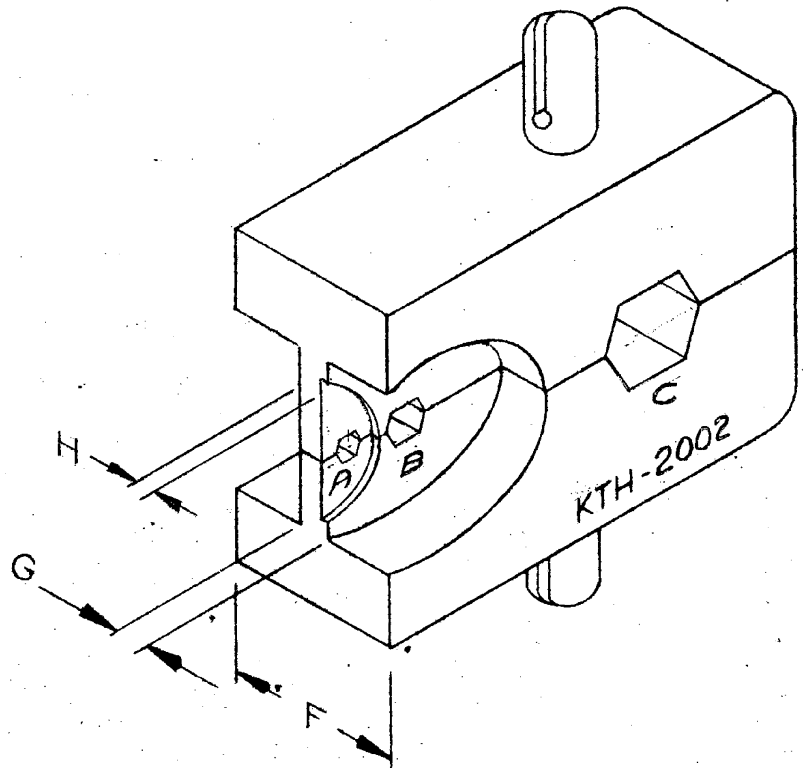

NOTES:
 1. FOR USE WITH RG-59, 62, 71 & 210/U CABLE GROUPS.
 2. MATERIAL: ALLOY STEEL; FINISH: BLACK OXIDE

HEX SIZES (ACROSS FLATS)				DIE WIDTH	WEB WIDTH		
A	B	C	D	F	G	H	I
.069	.100	.255	—	.400	.093	.080	—

- UNLESS OTHERWISE SPECIFIED:
1. TOLERANCES: FRACTIONS & 2 PLACE DECIMALS ± .010
3 PLACE DECIMALS ± .004
T. I. R. CONCENTRICITY OF ANY 2 DIAMETERS MAY NOT EXCEED HALF THE SUM OF THEIR TOLERANCES.
 2. REMOVE ALL BURRS, BREAK SHARP EDGES .005 MAX.
 3. NO FILLETS PERMITTED.
 4. SURFACE ROUGHNESS 63 MICROINCHES RMS MAX.
 5. ALL DIMENSIONS PRIOR TO PLATING.

REF:
FINISH
SPEC.
MATL.
SPEC.
CRIMP DIE
DRAWN JGL. DATE 15 JUN 72
APPR. DATE

KINGS ELECTRONICS
 40 MARBLEDALE ROAD
 T ICKAHOE, N. Y. 10707

KTH-2002