

Art.-Number: 701119

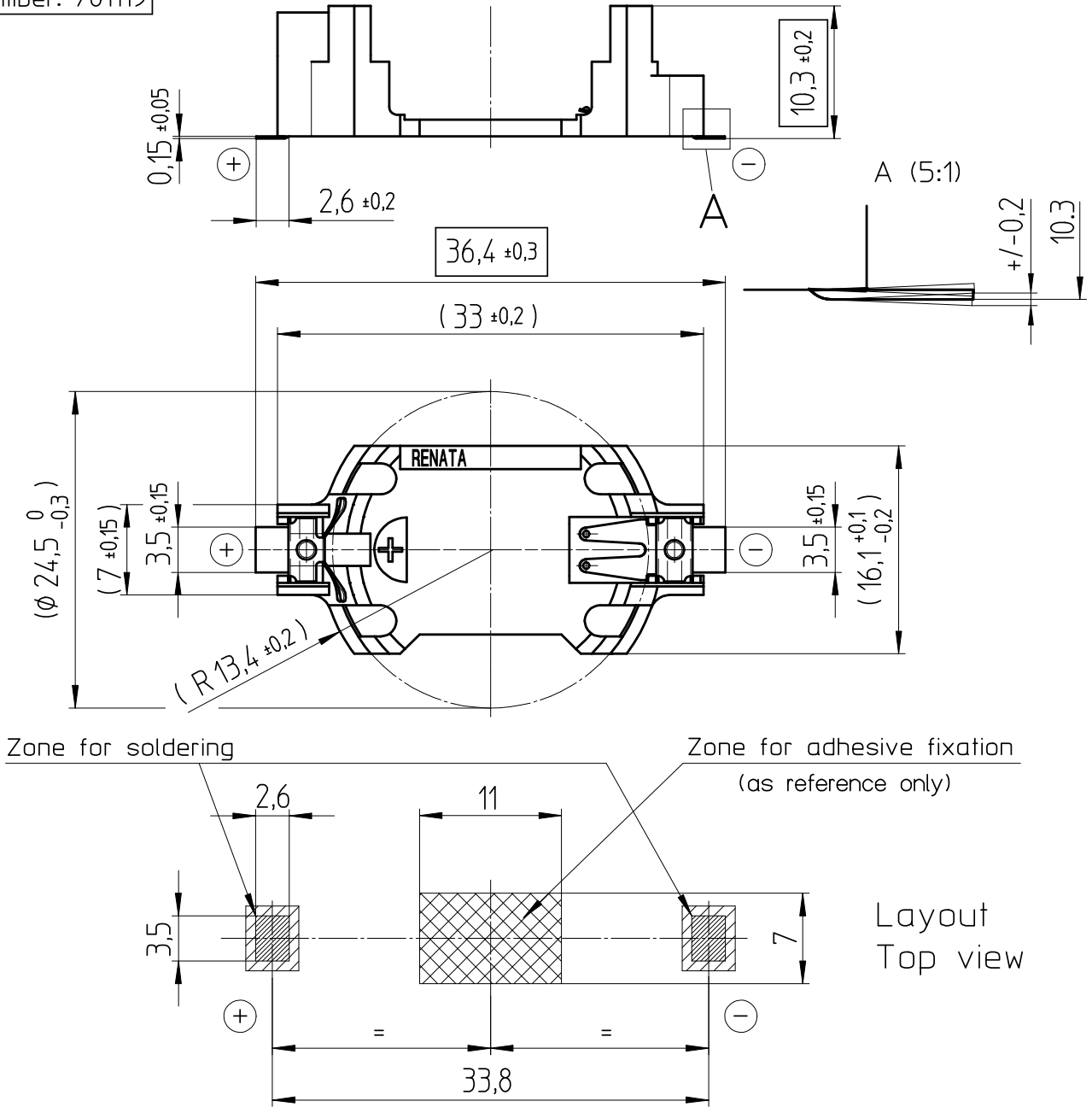

- Samples can deviate in the execution from the serie.

- Dimensions and tolerances can be specified only after the testing of the devices for the mass production definitely

- Holder material : heat resistant, glass-fiber reinforced LCP
- Battery contacts : spring stainless steel 301 nickel plated, thickness $10\mu\text{m}$
- Solder contacts : spring stainless steel 301 solder plated throughout 100% Sn, thickness $10\mu\text{m}$

All framed values will be used for dimension checking !

Rev.	①	07.09.07	MCI	Rev.	○			Customer's Approval			
Rev.	②	24.10.07	SRI	Rev.	○			Date			
Rev.	○			Rev.	○			Signature			
Titel:							Scale 2:1	Drawn	25.01.05	SRI	
SMTU2477N-LF								Checked	24.10.07	BBö	
								Approved	25.10.07	MHo	
							CH-4452 Itingen Switzerland		3.8763.4-2		