

## Installation Instructions for Cat. No. 105DHIST-FJ Adverse Location Visual Signals

### Description

The 105DHISTC-FJ (clear lens only) visual signal is a heavy duty, reliable, 8 Joule high intensity strobe that is both UL 1971 and CSFM listed for Hearing Impaired indoor use in compatible fire alarm systems. See Figure 6 for light output patterns and Table 2 for operating current information.

The 105DHIST\*-FJ (\*with amber, blue, clear, green, magenta, and red lenses) are UL and cUL (General Utility) and CSFMListed (Misc. Devices/Control Unit Accessories). The units also utilize an 8 joule strobe. See Table 2 for current information.

These strobes, when assembled in accordance with installation instructions, constitute a UL listed Type 4X enclosure. They are designed for use in industrial applications or in applications where a Type 4X enclosure is required. For General Utility (non-fire alarm) use, all units are UL and cUL Listed for Marine and outdoor visual signaling applications. When assembled in accordance with these instructions, 105 Series visual signals are UL listed for use in Hazardous Locations with Operating Temperatures listed in Table 1.

For specification details, see Tables 2 - 3.

Table 1. Hazardous Location Ratings

Cat. No.	Class	Division	Group	Operating Temperature
105DHIST*-FJ	I	2	A, B, C, D	T2A (280°C, 536°F)
	II	2	F, G	T3B (165°C, 329°F)
	III			T3B (165°C, 329°F)

\*Insert lens color: A - Amber, B - Blue, C - Clear, G - Green, M - Magenta, R - Red.

### Installation

## WARNING

**To prevent electrical shock, do not connect power until instructed to do so.**

Installation must be in accordance with local codes. The lens should be positioned up for outdoor applications.

1. Select a mounting configuration (Figure 5).

**NOTE:** When mounting using the Cat. No. 105BM mounting bracket, the Cat. No. 105BX outlet box attachment must also be used as shown in Figure 1.

2. Pull field wiring into the mounting attachment.
3. Install the mounting attachment as follows:

## WARNINGS

**The 105BX junction box, 105BM mounting bracket and 105PM pipe mount attachments are non-conductive plastic fixtures and do not provide earth-ground continuity when attached to metallic wiring systems. Therefore, they are intended for use with the 105DHIST series visual signals *only* when earth-grounding is not required.**

**The 105BX junction box, 105BM mounting bracket and 105PM pipe mount attachments *can* be used with metallic wiring systems *only* when installed at the end of a run.**

- b. **Cat. No. 105BM:** Using the four supplied screws, secure the mounting bracket to Cat. No. 105BX outlet box attachment as shown in Figure 1. Attach the adhesive backed gasket to the top of the 105BM mounting bracket, being careful to line up the holes in the gasket with the mounting holes in the outlet box.

- c. **Cat. No. 105PM:** Install 3/4" (19 mm) conduit. Screw the pipe mount attachment onto the 3/4" (19 mm) conduit. Attach the adhesive backed gasket to the top of the 105PM pipe mount attachment (Figure 3), being careful to line up the holes in the gasket with the mounting holes in the outlet box.

4. Attach the unit's wire leads to the field wiring as shown in Figure 4.

**NOTE:** It is not necessary to remove the lens from the Hi-Intensity Strobe Base to install the 105DHIST series beacons. See Figures 1, 3 or 4.

5. Secure the high intensity strobe base to the appropriate mounting attachment using four screws (supplied) as shown in Figure 3.
6. Apply power and verify operability.

- a. **Cat. No. 105BX:** Screw the outlet box attachment to the mounting surface (Figure 1) using two screws (not supplied) suitable for the surface. Attach the adhesive backed gasket to the top of the 105BX mounting box, being careful to line up the holes in the gasket with the mounting holes in the outlet box.

## Maintenance

The lens should be periodically cleaned using a mild detergent and water on a soft, clean, lint-free cloth.

### Light Source Replacement



## WARNING

To prevent electrical shock, before starting work on units disconnect power and, for strobe modules wait 5 minutes for stored energy to dissipate.

1. Unscrew the lens from the base.



## CAUTION

Do not touch the strobe tube or halogen bulb with bare fingers. Grasp the light source either by the base or using a soft, clean cloth.

2. For Strobe Tube Replacement:
  - a. Grasp the strobe tube by its base and pull straight up out of the strobe tube socket (Figure 2).
  - b. Grasp the new strobe tube by the strobe tube base and press into the strobe tube socket.
3. Ensure that the clear gasket is on the base with the flared, open end facing down. Screw the lens onto the base.
4. Apply power and verify operability.

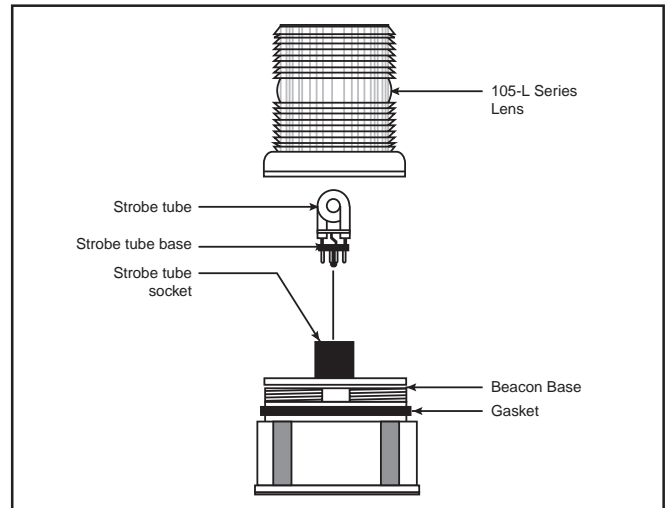

Figure 2. Strobe Tube Replacement

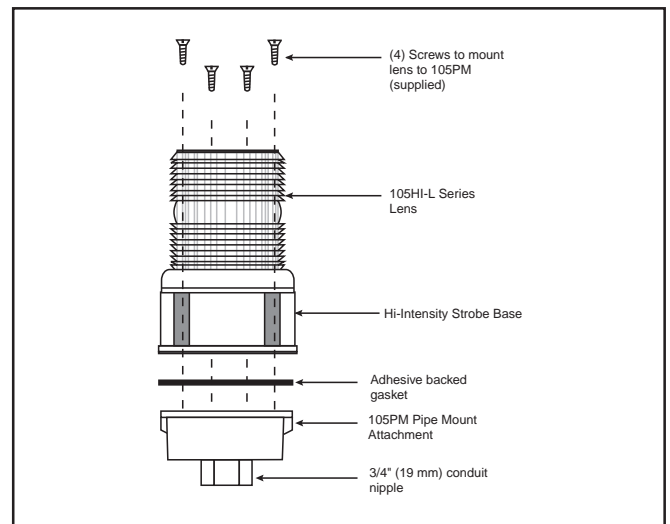

Figure 3. Securing the 105DHIST Series Beacon to the 105PM Pipe Mount Attachment

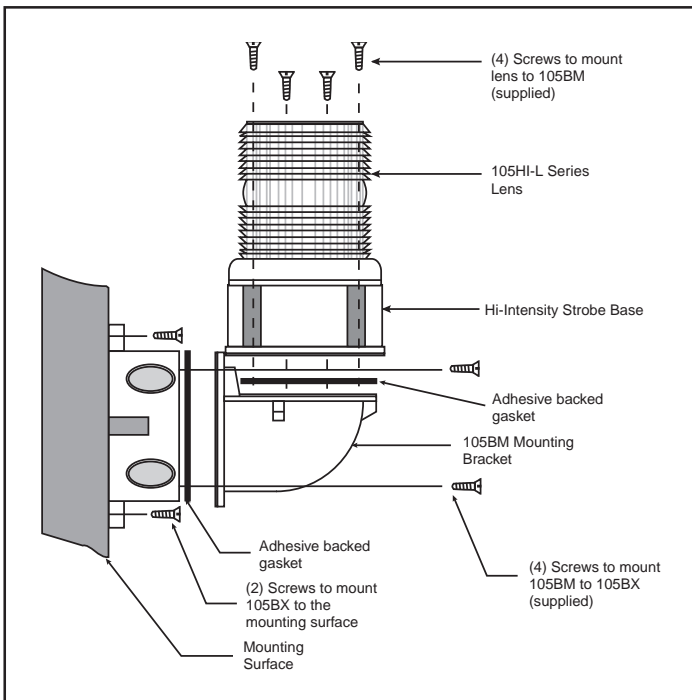

Figure 1. Mounting Cat. No. 105BM Mounting Bracket

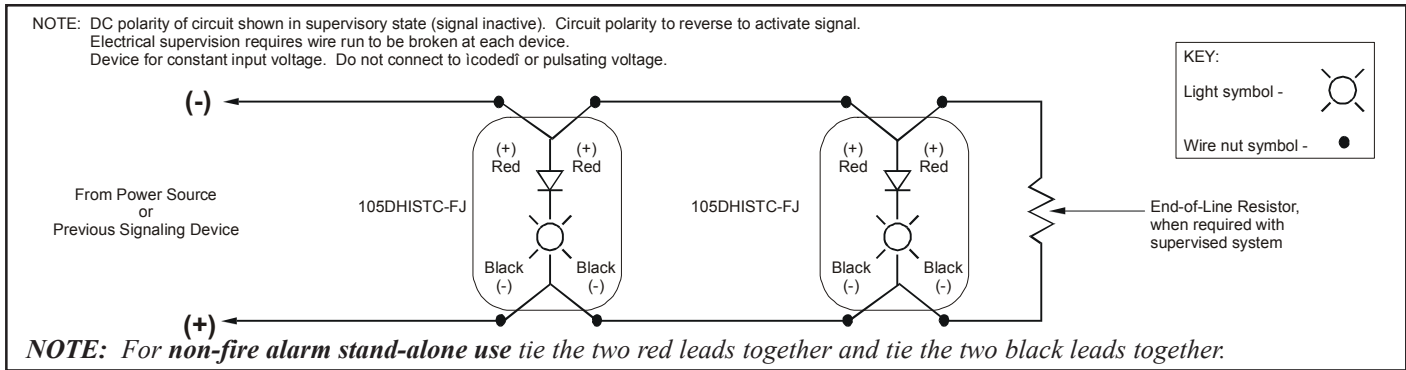

Figure 4. Wiring Diagram for the 105DHIST-FJ Series

Table 2. 105DHIST-FJ Series Electrical Specifications

Voltage	Operating Current*		Initial Surge Inrush Current		Repetitive Surge Current	
	RMS Current (A)	Mean Current (A)	Current (A)	Time (mS)	Current (A)	Time (mS)
20V DC	1.08	0.84	2.70	1.10	2.24	450
24V DC	0.95	0.69	2.97	1.13	2.21	400
28V DC	0.85	0.66	3.06	1.24	2.16	381
30V DC	0.83	0.64	3.14	1.27	2.14	360

\*Use the operating current to establish the wire gauge and standby power requirements. Consult the control unit manufacturer to determine surge and peak current effects and maximum number of strobes on the system.

	105DHIST Series
Mounted on a Cat. No. 105PM Pipe Mount Attachment	
Mounted on a Cat. No. 105BX Outlet Box Attachment	
Mounted on a Cat. No. 105BM Mounting Bracket with the Cat. No. 105BX Outlet Box Attachment	

Figure 5. Mounting Configurations

### Wall Mount, Dome Horizontal, Vertical and Horizontal Viewing Plane

Angle	Intensity (Cd)	UL Limit as % of 0 axis rating	Product Light Intensity as % of UL 0 axis rating
90	94.4	12 %	363 %
85	58.9	12 %	227 %
80	30.9	12 %	119 %
75	22.2	13 %	85 %
70	21.6	15 %	83 %
65	23.8	16 %	92 %
60	26.6	18 %	102 %
55	28.6	22 %	110 %
50	29.4	27 %	113 %
45	29.6	34 %	114 %
40	29.2	46 %	112 %
35	29.8	65 %	115 %
30	32.2	90 %	124 %
25	31.7	90 %	122 %
20	28.5	90 %	110 %
15	27.0	90 %	104 %
10	24.2	90 %	93 %
5	25.8	90 %	99 %
0	<b>26.0</b>	<b>100 %</b>	<b>100 %</b>
-5	25.8	90 %	99 %
-10	24.2	90 %	93 %
-15	27.0	90 %	104 %
-20	28.5	90 %	110 %
-25	31.7	90 %	122 %
-30	32.2	90 %	124 %
-35	29.8	65 %	115 %
-40	29.2	46 %	112 %
-45	29.6	34 %	114 %
-50	29.4	27 %	113 %
-55	28.6	22 %	110 %
-60	26.6	18 %	102 %
-65	23.8	16 %	92 %
-70	21.6	15 %	83 %
-75	22.2	13 %	85 %
-80	30.9	12 %	119 %
-85	58.9	12 %	227 %
-90	94.4	12 %	363 %

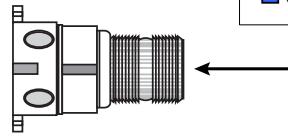

■ Intensity (Cd)  
■ UL Rating

0° axis looking at end of dome

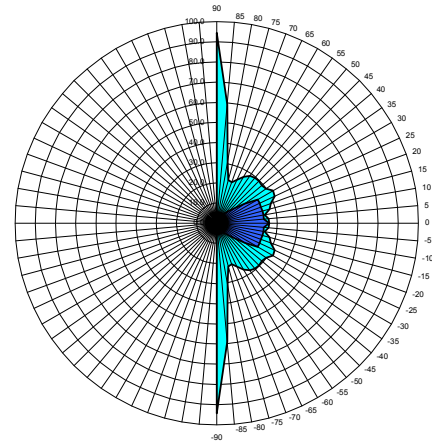

UL 1971 Hearing Impaired: 26 cd wall rating  
UL 1638 General Utility: 26 cd at 0° axis

### Wall Mount, Dome Down, Vertical Viewing Plane

Intensity of Horizontal plane is same as 0° angle of vertical, 360° around

Angle	Intensity (Cd)	UL Limit as % of 0 axis rating	Product Light Intensity as % of UL 0 axis rating
90	0.8		3 %
85	0.8		3 %
80	1.8		7 %
75	3.7		16 %
70	4.7		19 %
65	6.9		29 %
60	7.5		31 %
55	7.7		32 %
50	8.2		34 %
45	9.5		39 %
40	11.4		48 %
35	14.1		59 %
30	14.8		62 %
25	19.0		79 %
20	21.6		90 %
15	22.1		92 %
10	30.8		129 %
5	58.8		245 %
0	<b>94.2</b>	<b>100 %</b>	<b>393 %</b>
-5	58.8	90 %	245 %
-10	30.8	90 %	129 %
-15	22.1	90 %	92 %
-20	21.6	90 %	90 %
-25	23.8	90 %	99 %
-30	26.6	90 %	111 %
-35	28.5	85 %	119 %
-40	29.4	46 %	122 %
-45	29.5	34 %	123 %
-50	29.1	27 %	121 %
-55	29.8	22 %	124 %
-60	32.2	18 %	134 %
-65	31.6	16 %	132 %
-70	29.2	15 %	122 %
-75	27.0	13 %	112 %
-80	24.2	12 %	101 %
-85	25.7	12 %	107 %
-90	26.0	12 %	108 %

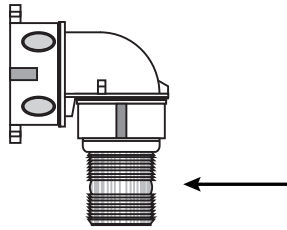

■ Intensity (Cd)  
■ UL Rating

0° axis looking at side of dome

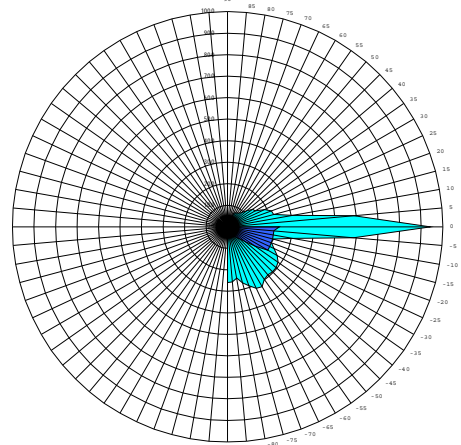

UL 1971 Hearing Impaired: 24 cd wall  
UL 1638 General Utility: 94 cd at 0° axis

### Ceiling Mount

Angle	Intensity (Cd)	UL Limit as % of 0 axis rating	Product Light Intensity as % of UL 0 axis rating
90	94.4	25 %	363 %
85	58.9	25 %	227 %
80	30.9	30 %	119 %
75	22.2	30 %	85 %
70	21.6	35 %	83 %
65	23.8	35 %	92 %
60	26.6	40 %	102 %
55	28.6	45 %	110 %
50	29.4	55 %	113 %
45	29.6	75 %	114 %
40	29.2	75 %	112 %
35	29.8	75 %	115 %
30	32.2	75 %	124 %
25	31.7	90 %	122 %
20	28.5	90 %	110 %
15	27.0	90 %	104 %
10	24.2	90 %	93 %
5	25.8	90 %	99 %
0	<b>26.0</b>	<b>100 %</b>	<b>100 %</b>
-5	25.8	90 %	99 %
-10	24.2	90 %	93 %
-15	27.0	90 %	104 %
-20	28.5	90 %	110 %
-25	31.7	90 %	122 %
-30	32.2	75 %	124 %
-35	29.8	75 %	115 %
-40	29.2	75 %	112 %
-45	29.6	75 %	114 %
-50	29.4	55 %	113 %
-55	28.6	45 %	110 %
-60	26.6	40 %	102 %
-65	23.8	35 %	92 %
-70	21.6	35 %	83 %
-75	22.2	30 %	85 %
-80	30.9	30 %	119 %
-85	58.9	25 %	227 %
-90	94.4	25 %	363 %

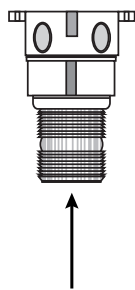

■ Intensity (Cd)  
■ UL Rating

0° axis looking at end of dome

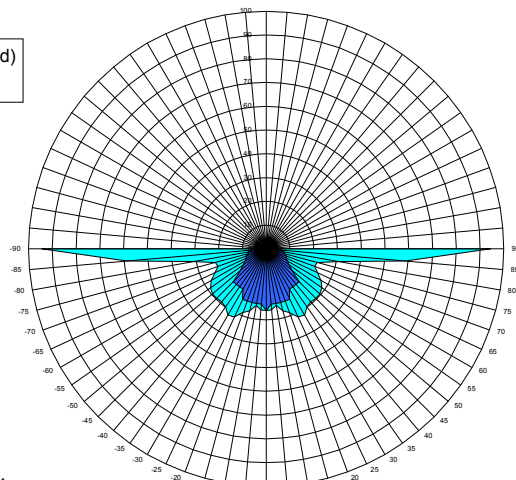

UL 1971 Hearing Impaired: 26 cd ceiling  
UL 1638 General Utility: 26 cd at 0° axis

Figure 6. Light Output Patterns for 105DHISTC-FJ (Unit with clear lens only)

Table 3. Specifications

Cat. No.	Module Type	Lamp Ratings	Voltage	Current
105DHIST*-FJ	High Intensity 8 Joule Strobe	800,000 Peak Cd 3,000 Hours <sup>1</sup>	Table 2	Table 2

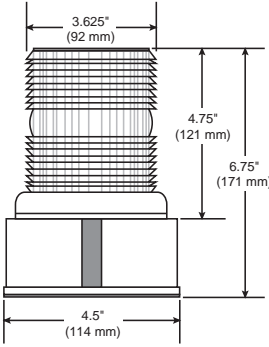

3.625" (92 mm)  
4.75" (121 mm)  
6.75" (171 mm)  
4.5" (114 mm)

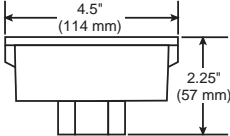

4.5" (114 mm)  
2.25" (57 mm)

105PM Pipe Mount Attachment

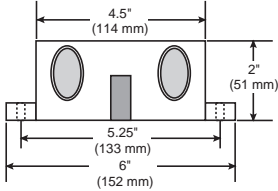

4.5" (114 mm)  
2" (51 mm)  
5.25" (133 mm)  
6" (152 mm)

105BX Outlet Box Attachment

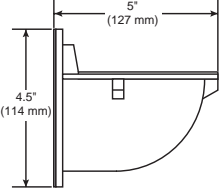

5" (127 mm)  
4.5" (114 mm)

105BM Mounting Bracket  
(use with 105BX)

\*Insert lens color: A - Amber, B - Blue, C - Clear, G - Green, M - Magenta, R - Red.

<sup>1</sup>Strobe tube life @ operating power to 75% efficiency.

**Contacting Edwards:**

Phone: (203) 699-3000

E-Mail: [techsupport@edwards-signals.com](mailto:techsupport@edwards-signals.com)  
[customerservice@edwards-signals.com](mailto:customerservice@edwards-signals.com)

Website: <http://www.edwards-signals.com>