

| No. | Changes and/or Note No. | Date | Intr. | No. | Changes and/or Note No. | Date | Intr. |
|-----|-------------------------|------|-------|-----|-------------------------|------|-------|
|-----|-------------------------|------|-------|-----|-------------------------|------|-------|

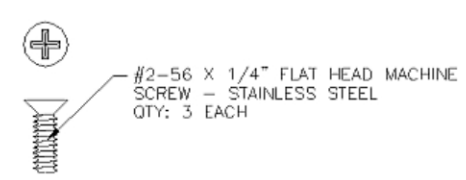

- Connector Cover:**
1. Material: Zinc Alloy
 2. Finish: Bright Zinc Chromate
 3. Dimensions: Inches [mm]
 4. Tolerance: ± 0.015 [0.381]

| | | | |
|----------------|--------------|-------|---------------|
| DATE 031016 | DRAWN MRR | SCALE | MATERIAL TYPE |
| | APPROVED | | REPLACES |

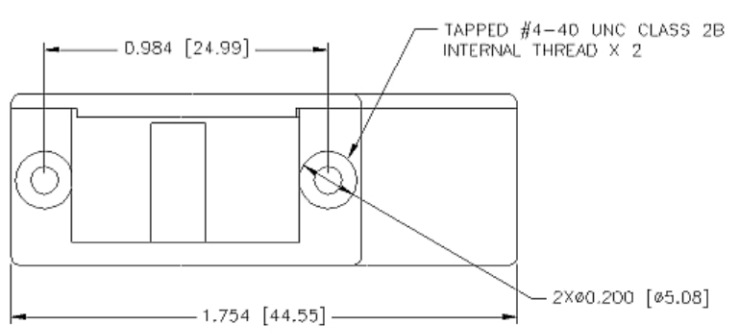
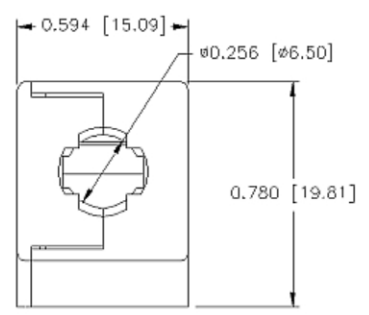
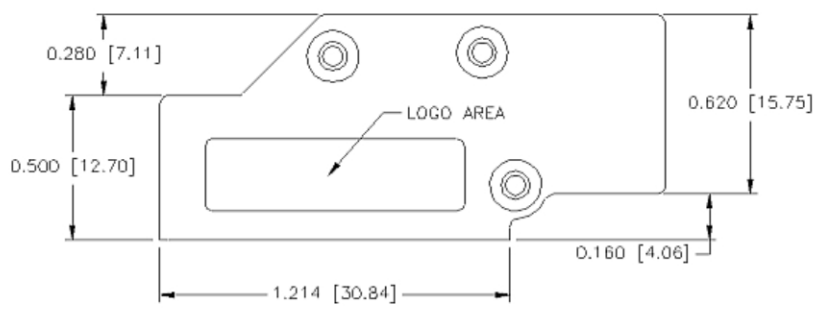

DCMR09-SL
Diecasted Hood
Farnell Code : 4861772

| | |
|---------------------|--|
| DRAWING No | |
| 1060-0135-11 | |