

TLV2541, TLV2542, TLV2545 2.7-V TO 5.5-V, LOW-POWER, 12-BIT, 140/200 KSPS, SERIAL ANALOG-TO-DIGITAL CONVERTERS WITH AUTOPOWER DOWN

SLAS245D – MARCH 2000 – REVISED MAY 2003

- Maximum Throughput . . . 140/200 KSPS
- Built-In Conversion Clock
- INL/DNL: ± 1 LSB Max, SINAD: 72 dB, SFDR: 85 dB, $f_i = 20$ kHz
- SPI/DSP-Compatible Serial Interface
- Single Supply: 2.7 Vdc to 5.5 Vdc
- Rail-to-Rail Analog Input With 500 kHz BW
- Three Options Available:
 - TLV2541: Single Channel Input
 - TLV2542: Dual Channels With Autosweep
 - TLV2545: Single Channel With Pseudo-Differential Input
- Low Power With Autopower Down
 - Operating Current: 1 mA at 2.7 V, 1.5 mA at 5 V
 - Autopower Down: 2 μ A at 2.7 V, 5 μ A at 5 V
- Small 8-Pin MSOP and SOIC Packages

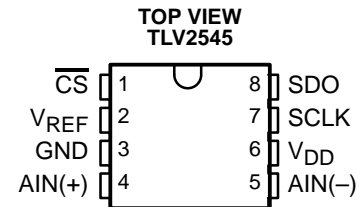
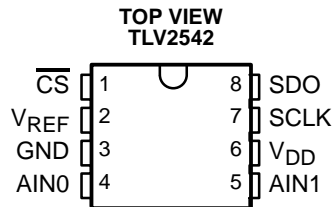
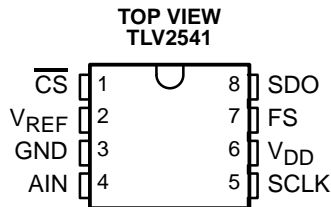

description

The TLV2541, TLV2542, and TLV2545 are a family of high performance, 12-bit, low power, miniature, CMOS analog-to-digital converters (ADC). The TLV254x family operates from a single 2.7-V to 5.5-V supply. Devices are available with single, dual, or single pseudo-differential inputs. Each device has a chip select (\overline{CS}), serial clock (SCLK), and serial data output (SDO) that provides a direct 3-wire interface to the serial port of most popular host microprocessors (SPI interface). When interfaced with a TMS320™ DSP, a frame sync signal (FS) can be used to indicate the start of a serial data frame on \overline{CS} for all devices or FS for the TLV2541.

TLV2541, TLV2542, and TLV2545 are designed to operate with very low power consumption. The power saving feature is further enhanced with an autopower-down mode. This product family features a high-speed serial link to modern host processors with SCLK up to 20 MHz. The maximum SCLK frequency is dependent upon the mode of operation (see Table 1). The TLV254x family uses the built-in oscillator as the conversion clock, providing a 3.5- μ s conversion time.

AVAILABLE OPTIONS

T _A	PACKAGED DEVICES	
	8-MSOP (DGK)	8-SOIC (D)
0°C to 70°C	TLV2541CDGK (AGZ)	
	TLV2542CDGK (AHB)	
	TLV2545CDGK (AHD)	
–40°C to 85°C	TLV2541IDGK (AHA)	TLV2541ID
	TLV2542IDGK (AHC)	TLV2542ID
	TLV2545IDGK (AHE)	TLV2545ID



Please be aware that an important notice concerning availability, standard warranty, and use in critical applications of Texas Instruments semiconductor products and disclaimers thereto appears at the end of this data sheet.

TMS320 is a trademark of Texas Instruments.

PRODUCTION DATA information is current as of publication date. Products conform to specifications per the terms of Texas Instruments standard warranty. Production processing does not necessarily include testing of all parameters.



POST OFFICE BOX 655303 • DALLAS, TEXAS 75265

Copyright © 2000 – 2003, Texas Instruments Incorporated

TLV2541, TLV2542, TLV2545
2.7-V TO 5.5-V, LOW-POWER, 12-BIT, 140/200 KSPS,
SERIAL ANALOG-TO-DIGITAL CONVERTERS WITH AUTOPOWER DOWN

SLAS245D –MARCH 2000 – REVISED MAY 2003

functional block diagram

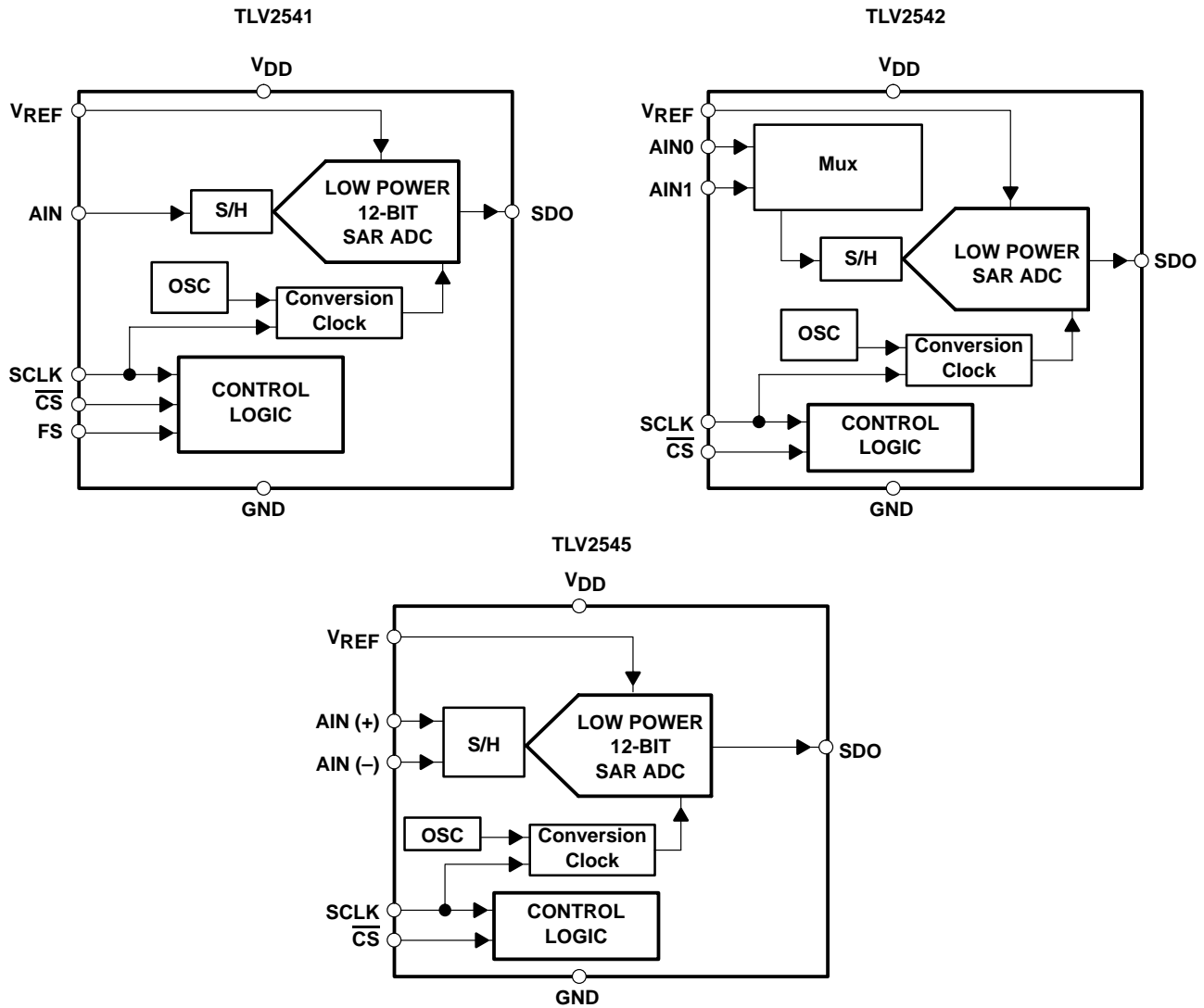

TLV2541, TLV2542, TLV2545
2.7-V TO 5.5-V, LOW-POWER, 12-BIT, 140/200 KSPS,
SERIAL ANALOG-TO-DIGITAL CONVERTERS WITH AUTOPOWER DOWN
SLAS245D –MARCH 2000 – REVISED MAY 2003

Terminal Functions

TLV2541

TERMINAL		I/O	DESCRIPTION
NAME	NO.		
AIN	4	I	Analog input channel
$\overline{\text{CS}}$	1	I	Chip select. A high-to-low transition on the $\overline{\text{CS}}$ input removes SDO from 3-state within a maximum setup time. $\overline{\text{CS}}$ can be used as the FS pin when a dedicated DSP serial port is used.
FS	7	I	DSP frame sync input. Indication of the start of a serial data frame. Tie this terminal to V_{DD} if not used.
GND	3	I	Ground return for the internal circuitry. Unless otherwise noted, all voltage measurements are with respect to GND.
SCLK	5	I	Output serial clock. This terminal receives the serial SCLK from the host processor.
SDO	8	O	The 3-state serial output for the A/D conversion result. SDO is kept in the high-impedance state until $\overline{\text{CS}}$ falling edge or FS rising edge, whichever occurs first. The output format is MSB first. When FS is not used ($\text{FS} = 1$ at the falling edge of $\overline{\text{CS}}$): The MSB is presented to the SDO pin after $\overline{\text{CS}}$ falling edge and output data is valid on the first falling edge of SCLK. When $\overline{\text{CS}}$ and FS are both used ($\text{FS} = 0$ at the falling edge of $\overline{\text{CS}}$): The MSB is presented to the SDO pin after the falling edge of $\overline{\text{CS}}$. When $\overline{\text{CS}}$ is tied/held low, the MSB is presented on SDO after the rising FS. Output data is valid on the first falling edge of SCLK. (This is typically used with an active FS from a DSP using a dedicated serial port.)
V_{DD}	6	I	Positive supply voltage
V_{REF}	2	I	External reference input

TLV2542/45

TERMINAL		I/O	DESCRIPTION
NAME	NO.		
AIN0 /AIN(+)	4	I	Analog input channel 0 for TLV2542—Positive input for TLV2545.
AIN1/AIN (-)	5	I	Analog input channel 1 for TLV2542—Inverted input for TLV2545.
$\overline{\text{CS}}$	1	I	Chip select. A high-to-low transition on $\overline{\text{CS}}$ removes SDO from 3-state within a maximum delay time. This pin can be connected to the frame sync of a DSP using a dedicated serial port.
GND	3	I	Ground return for the internal circuitry. Unless otherwise noted, all voltage measurements are with respect to GND.
SCLK	7	I	Output serial clock. This terminal receives the serial SCLK from the host processor.
SDO	8	O	The 3-state serial output for the A/D conversion result. SDO is kept in the high-impedance state when $\overline{\text{CS}}$ is high and presents output data after the $\overline{\text{CS}}$ falling edge until the LSB is presented. The output format is MSB first. SDO returns to the Hi-Z state after the 16th SCLK. Output data is valid on the falling SCLK edge.
V_{DD}	6	I	Positive supply voltage
V_{REF}	2	I	External reference input

detailed description

The TLV2541, TLV2542, and TLV2545 are successive approximation (SAR) ADCs utilizing a charge redistribution DAC. Figure 1 shows a simplified version of the ADC.

The sampling capacitor acquires the signal on AIN during the sampling period. When the conversion process starts, the SAR control logic and charge redistribution DAC are used to add and subtract fixed amounts of charge from the sampling capacitor to bring the comparator into a balanced condition. When the comparator is balanced, the conversion is complete and the ADC output code is generated.

TLV2541, TLV2542, TLV2545
2.7-V TO 5.5-V, LOW-POWER, 12-BIT, 140/200 KSPS,
SERIAL ANALOG-TO-DIGITAL CONVERTERS WITH AUTOPOWER DOWN

SLAS245D –MARCH 2000 – REVISED MAY 2003

detailed description (continued)

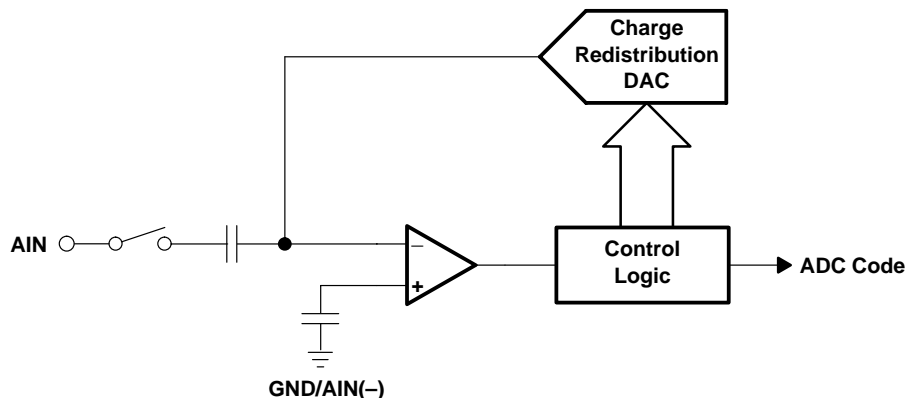

Figure 1. Simplified SAR Circuit

serial interface

OUTPUT DATA FORMAT	
MSB	LSB
D15–D4	D3–D0
Conversion result (OD11–OD0)	Don't care

The output data format is binary (unipolar straight binary).

binary

Zero-scale code = 000h, $V_{code} = GND$
 Full-scale code = FFFh, $V_{code} = V_{REF} - 1 \text{ LSB}$

pseudo-differential inputs

The TLV2545 operates in pseudo-differential mode. The inverted input is available on pin 5. It can have a maximum input ripple of $\pm 0.2 \text{ V}$. This is normally used for ground noise rejection.

control and timing

start of the cycle

Each cycle may be started by either \overline{CS} , FS, or a combination of both. The internal state machine requires one SCLK high-to-low transition to determine the state of these control signals so internal blocks can be powered up in an active cycle. Special care to SPI mode is necessary. Make sure there is at least one SCLK whenever \overline{CS} (pin 1) is high to ensure proper operation.

TLV2541

- Control via \overline{CS} (FS = 1 at the falling edge of \overline{CS})—The falling edge of \overline{CS} is the start of the cycle. The MSB should be read on the first falling SCLK edge after \overline{CS} is low. Output data changes on the rising edge of SCLK. This is typically used for a microcontroller with an SPI interface, although it can also be used for a DSP. The microcontroller SPI interface should be programmed for CPOL = 0 (serial clock referenced to ground) and CPHA = 1 (data is valid on the falling edge of the serial clock). At least one falling edge transition on SCLK is needed whenever \overline{CS} is brought high.
- Control via FS (\overline{CS} is tied/held low)—The MSB is presented after the rising edge of FS. The falling edge of FS is the start of the cycle. The MSB should be read on the first falling edge of SCLK after FS is low. This is the typical configuration when the ADC is the only device on the DSP serial port.



control and timing (continued)

- Control via both \overline{CS} and FS—The MSB is presented after the falling edge of \overline{CS} . The falling edge of FS is the start of the sampling cycle. The MSB should be read on the first falling SCLK edge after FS is low. Output data changes on the rising edge of SCLK. This configuration is typically used for multiple devices connected to a TMS320 DSP.

TLV2542/5

All control is provided using \overline{CS} (pin 1) on the TLV2542 and TLV2545. The cycle is started on the falling edge transition provided by either a \overline{CS} signal from an SPI microcontroller or FS signal from a TMS320 DSP. Timing is similar to the TLV2541, with control via \overline{CS} only.

TLV2542 channel MUX reset cycle

The TLV2542 uses \overline{CS} to reset the analog input multiplexer. A short active \overline{CS} cycle (4 to 7 SCLKs) resets the MUX to AIN0. When the \overline{CS} cycle time is greater than 7 SCLKs in duration, as in the case for a complete conversion cycle (\overline{CS} is low for 16 SCLKs plus maximum conversion time), the MUX toggles to the next channel (see Figure 4 for timing).

sampling

The converter sample time is 12 SCLKs in duration, beginning on the fifth SCLK received after the converter has received a high-to-low \overline{CS} transition (or a high-to-low FS transition for the TLV2541).

conversion

The TLV2541, TLV2542, and TLV2545 complete conversions in the following manner. The conversion is started after the 16th SCLK falling edge and takes 3.5 μ s to complete. Enough time (for conversion) should be allowed before a rising \overline{CS} or FS edge so that no conversion is terminated prematurely.

TLV2542 input channel selection is toggled on each rising \overline{CS} edge. The MUX channel can be reset to AIN0 via \overline{CS} as described in the earlier section and in Figure 4. The input is sampled for 12 SCLKs, converted, and the result is presented on SDO during the next cycle. Care should also be taken to allow enough time between samples to avoid prematurely terminating the cycle, which occurs on a rising \overline{CS} transition if the conversion is not complete.

The SDO data presented during a cycle is the result of the conversion of the sample taken during the previous cycle.

timing diagrams/conversion cycles

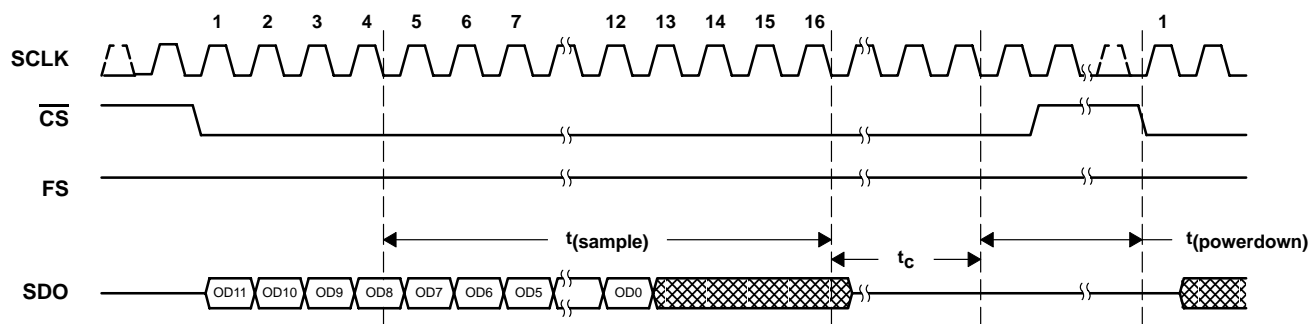

Figure 2. TLV2541 Timing: Control via \overline{CS} (FS = 1)

TLV2541, TLV2542, TLV2545
2.7-V TO 5.5-V, LOW-POWER, 12-BIT, 140/200 KSPS,
SERIAL ANALOG-TO-DIGITAL CONVERTERS WITH AUTOPOWER DOWN

SLAS245D – MARCH 2000 – REVISED MAY 2003

timing diagrams/conversion cycles (continued)

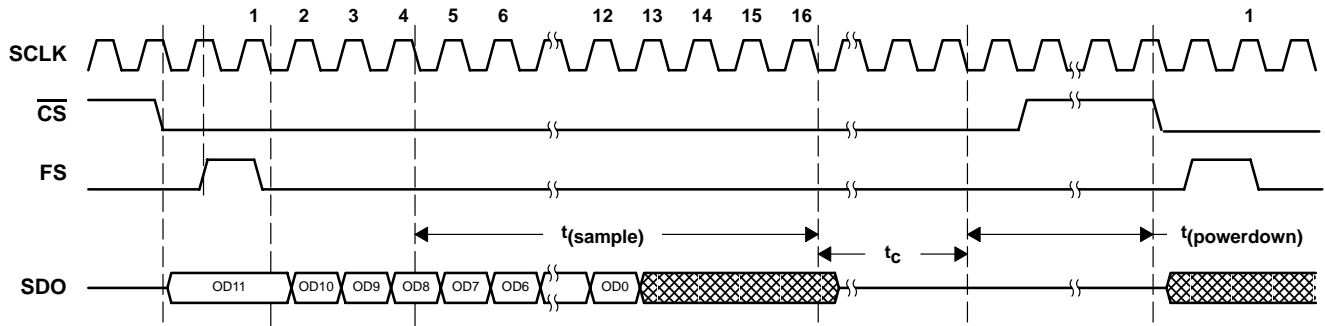

Figure 3. TLV2541 Timing: Control via \overline{CS} and FS or FS Only

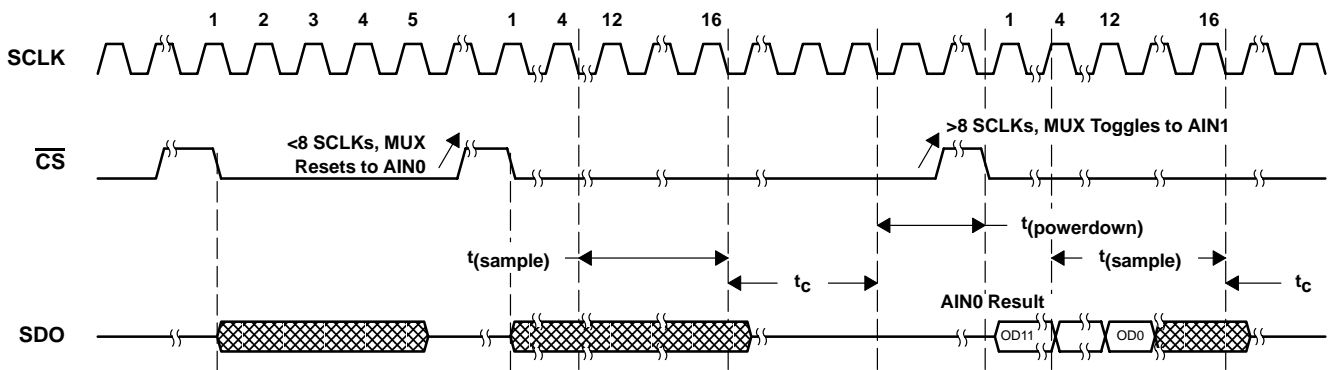

Figure 4. TLV2542 Reset Timing

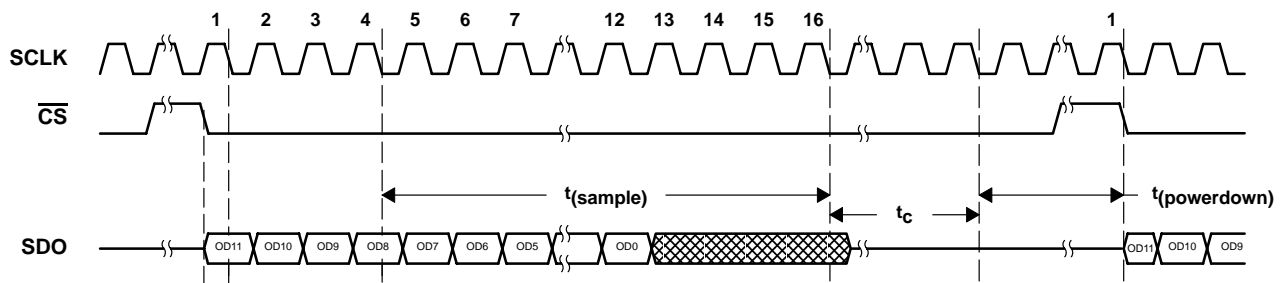

Figure 5. TLV2542 and TLV2545 Timing

using \overline{CS} as the FS input

When interfacing the TLV2541 with the TMS320 DSP, the FSR signal from the DSP may be connected to the \overline{CS} input if this is the only device on the serial port. This saves one output terminal from the DSP. (Output data changes on the falling edge of SCLK. This is the default configuration for the TLV2542 and TLV2545.)



using $\overline{\text{CS}}$ as the FS input (continued)

SCLK and conversion speed

The input frequency of SCLK can range from 100 kHz to 20 MHz maximum. The ADC conversion uses a separate internal oscillator with a minimum frequency of 4 MHz. The conversion cycle takes 14 internal oscillator clocks to complete. This leads to a 3.5- μs conversion time. For a 20-MHz SCLK, the minimum total cycle time is given by: $16 \times (1/20\text{M}) + 14 \times (1/4\text{M}) + \text{one SCLK} = 4.35 \mu\text{s}$. An additional SCLK is added to account for the required $\overline{\text{CS}}$ and/or FS high time. These times specify the minimum cycle time for an active $\overline{\text{CS}}$ or FS signal. If violated, the conversion terminates, invalidating the next data output cycle. Table 1 gives the maximum SCLK frequency for a given supply voltage and operational mode.

control via pin 1 ($\overline{\text{CS}}$, SPI interface)

All devices are compatible with this mode operation. A falling $\overline{\text{CS}}$ initiates the cycle (for TLV2541, the FS input is tied to V_{DD}). $\overline{\text{CS}}$ remains low for the entire cycle time (sample+convert+one SCLK) and can then be released.

NOTE:

IMPORTANT: A single SCLK is required whenever $\overline{\text{CS}}$ is high.

control via pin 1 ($\overline{\text{CS}}$, DSP interface)

All devices are compatible with this mode of operation. The FS signal from a DSP is connected directly to the $\overline{\text{CS}}$ input of the ADC. A falling edge on the $\overline{\text{CS}}$ input initiates the cycle. (For the TLV2541, the FS input can be tied to V_{DD} , although better performance can be achieved when using the FS input for control. Refer to the next section.) The $\overline{\text{CS}}$ input should remain low for the entire cycle time (sample+convert+one SCLK) and can then be released.

NOTE:

IMPORTANT: A single SCLK is required whenever $\overline{\text{CS}}$ is high. This should be of little consequence, since SCLK is normally always present when interfacing with a DSP.

control via pin 1 and pin 7 ($\overline{\text{CS}}$ and FS or FS only, DSP interface)

Only the TLV2541 is compatible with this mode of operation. The $\overline{\text{CS}}$ input to the ADC can be controlled via a general-purpose I/O pin from the DSP. The FS signal from the DSP is connected directly to the FS input of the ADC. A falling edge on $\overline{\text{CS}}$, if used, releases the MSB on the SDO output. When $\overline{\text{CS}}$ is not used, the rising FS edge releases the MSB. The falling edge on the FS input while SCLK is high initiates the cycle. The $\overline{\text{CS}}$ and FS inputs should remain low for the entire cycle time (sample+convert+one SCLK) and can then be released.

reference voltage

An external reference is applied via V_{REF} . The voltage level applied to this pin establishes the upper limit of the analog inputs to produce a full-scale reading. The value of V_{REF} and the analog input should not exceed the positive supply or be less than GND, consistent with the specified absolute maximum ratings. The digital output is at full scale when the input signal is equal to or higher than V_{REF} and at zero when the input signal is equal to or lower than GND.

power down and power up

Autopower down is built into these devices in order to reduce power consumption. The actual power savings depends on the inactive time between cycles and the power supply (loading) decoupling/storage capacitors. *Power-down takes effect immediately after the conversion is complete.* This is fast enough to provide some power savings between cycles with longer than 1 SCLK inactive time. *The device power goes down to 5 μA within 0.5 μs .* To achieve the lowest power-down current (*deep powerdown*) of 1 μA requires 2-ms inactive time between cycles. The power-down state is initiated at the end of conversion. These devices wake up *immediately* at the next falling edge of $\overline{\text{CS}}$ or the rising edge of FS.

TLV2541, TLV2542, TLV2545
2.7-V TO 5.5-V, LOW-POWER, 12-BIT, 140/200 KSPS,
SERIAL ANALOG-TO-DIGITAL CONVERTERS WITH AUTOPOWER DOWN

SLAS245D –MARCH 2000 – REVISED MAY 2003

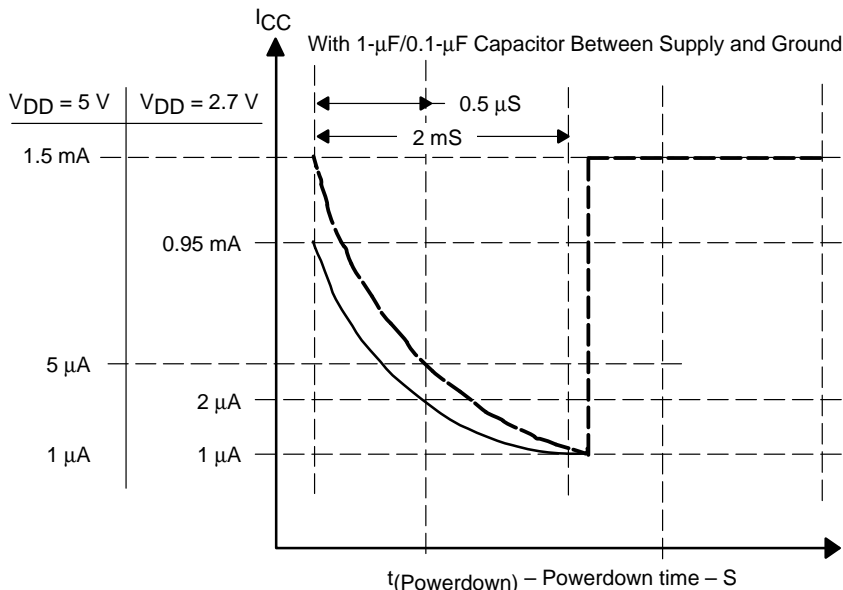

Table 1. Modes of Operation and Data Throughput

CONTROL PIN(s)/DEVICE	MAX SCLK (MHz) (50/50 duty cycle)		APPROXIMATE CONVERSION THROUGHPUT (ksp/s)	
	V _{DD} = 2.7 V	V _{DD} = 4.5 V	V _{DD} = 2.7 V	V _{DD} = 4.5 V
$\overline{\text{CS}}$ control only (TLV2541 only)				
For SPI interface†	10	15	175	200
For DSP interface (Use $\overline{\text{CS}}$ as FS)‡	5	8	140	175
$\overline{\text{CS}}$ and FS control (TLV2541 only)§				
DSP interface	15	20	200	200

† See Figure 29(a).

‡ See Figure 29(b).

§ See Figure 29(c).

absolute maximum ratings over operating free-air temperature (unless otherwise noted)¶

- Supply voltage range, GND to V_{DD} -0.3 V to 6.5 V
- Analog input voltage range -0.3 V to V_{DD} + 0.3 V
- Reference input voltage V_{DD} + 0.3 V
- Digital input voltage range -0.3 V to V_{DD} + 0.3 V
- Operating virtual junction temperature range, T_J -40°C to 150°C
- Operating free-air temperature range, T_A: C 0°C to 70°C
- I -40°C to 85°C
- Storage temperature range, T_{stg} -65°C to 150°C
- Lead temperature 1,6 mm (1/16 inch) from case for 10 seconds 260°C

¶ Stresses beyond those listed under “absolute maximum ratings” may cause permanent damage to the device. These are stress ratings only, and functional operation of the device at these or any other conditions beyond those indicated under “recommended operating conditions” is not implied. Exposure to absolute-maximum-rated conditions for extended periods may affect device reliability.



TLV2541, TLV2542, TLV2545
2.7-V TO 5.5-V, LOW-POWER, 12-BIT, 140/200 KSPS,
SERIAL ANALOG-TO-DIGITAL CONVERTERS WITH AUTOPOWER DOWN

SLAS245D –MARCH 2000 – REVISED MAY 2003

recommended operating conditions

		MIN	NOM	MAX	UNIT
Supply voltage, V_{DD}		2.7	3.3	5.5	V
Positive external reference voltage input, V_{REFP} (see Note 1)		2		V_{DD}	V
Analog input voltage (see Note 1)		0		V_{DD}	V
High level control input voltage, V_{IH}		2.1			V
Low-level control input voltage, V_{IL}				0.6	V
Setup time, \overline{CS} falling edge before first SCLK falling edge, $t_{su}(CSL-SCLKL)$	$V_{DD} = REF = 4.5\text{ V}$	40			ns
	$V_{DD} = REF = 2.7\text{ V}$	70			
Hold time, \overline{CS} falling edge after SCLK falling edge, $t_h(SCLKL-CSL)$		5			ns
Delay time, delay from \overline{CS} falling edge to FS rising edge, $t_d(CSL-FSH)$ (TLV2541 only)		0.5		7	SCLKs
Setup time, FS rising edge before SCLK falling edge, $t_{su}(FSH-SCLKL)$ (TLV2541 only)		0.35			SCLKs
Hold time, FS high after SCLK falling edge, $t_h(SCLKL-FSL)$ (TLV2541 only)				0.65	SCLKs
Pulse width \overline{CS} high time, $t_w(H_CS)$		100			ns
Pulse width FS high time, $t_w(H_FS)$ (TLV2541 only)		0.75			SCLKs
SCLK cycle time, $V_{DD} = 3.6\text{ V}$ to 2.7 V , $t_c(SCLK)$ (maximum tolerance of 40/60 duty cycle)		90		10000	ns
SCLK cycle time, $V_{DD} = 5.5\text{ V}$ to 4.5 V , $t_c(SCLK)$ (maximum tolerance of 40/60 duty cycle)		50		10000	ns
Pulse width low time, $t_w(L_SCLK)$		0.4		0.6	SCLK
Pulse width high time, $t_w(H_SCLK)$		0.4		0.6	SCLK
Hold time, hold from end of conversion to \overline{CS} high, $t_h(EOC-CSH)$ (EOC is internal, indicates end of conversion time, t_c)			0.05		μs
Active \overline{CS} cycle time to reset internal MUX to AIN_0 , $t_{(reset\ cycle)}$ (TLV2542 only)		4		7	SCLKs
Delay time, delay from \overline{CS} falling edge to SDO valid, $t_d(CSL-SDOV)$	$V_{DD} = REF = 4.5\text{ V}$, 25-pF load			40	ns
	$V_{DD} = REF = 2.7\text{ V}$, 25-pF load			70	
Delay time, delay from FS falling edge to SDO valid, $t_d(FSL-SDOV)$ (TLV2541 only)	$V_{DD} = REF = 4.5\text{ V}$, 25-pF load			1	ns
	$V_{DD} = REF = 2.7\text{ V}$, 25-pF load			1	
Delay time, delay from SCLK rising edge to SDO valid, $t_d(SCLKH-SDOV)$	$V_{DD} = REF = 4.5\text{ V}$, 25-pF load			11	ns
	$V_{DD} = REF = 2.7\text{ V}$, 25-pF load			21	
Delay time, delay from 17th SCLK rising edge to SDO 3-state, $t_d(SCLK17H-SDOZ)$	$V_{DD} = REF = 4.5\text{ V}$, 25-pF load			30	ns
	$V_{DD} = REF = 2.7\text{ V}$, 25-pF load			60	
Conversion time, t_c	Conversion clock = internal oscillator	2.1	2.6	3.5	μs
Sampling time, $t_{(sample)}$	See Note 2	300			ns
Operating free-air temperature, T_A	TLV2541/2/5C	0		70	$^{\circ}\text{C}$
	TLV2541/2/5I	-40		85	

- NOTES: 1. Analog input voltages greater than that applied to V_{REF} convert as all ones (111111111111), while input voltages less than that applied to GND convert as all zeros(000000000000).
2. Minimal $t_{(sample)}$ is given by $0.9 \times 50\text{ pF} \times (R_S + 0.5\text{ k}\Omega)$, where R_S is the source output impedance.



TLV2541, TLV2542, TLV2545
2.7-V TO 5.5-V, LOW-POWER, 12-BIT, 140/200 KSPS,
SERIAL ANALOG-TO-DIGITAL CONVERTERS WITH AUTOPOWER DOWN

SLAS245D –MARCH 2000 – REVISED MAY 2003

electrical characteristics over recommended operating free-air temperature range,
 $V_{DD} = V_{REF} = 2.7\text{ V to }5.5\text{ V}$ (unless otherwise noted)

PARAMETER		TEST CONDITIONS	MIN	TYP†	MAX	UNIT	
V_{OH}	High-level output voltage	$V_{DD} = 5.5\text{ V}, I_{OH} = -0.2\text{ mA}$ at 30-pF load	2.4			V	
		$V_{DD} = 2.7\text{ V}, I_{OH} = -20\text{ }\mu\text{A}$ at 30-pF load	$V_{DD}-0.2$				
V_{OL}	Low-level output voltage	$V_{DD} = 5.5\text{ V}, I_{OL} = 0.8\text{ mA}$ at 30-pF load			0.4	V	
		$V_{DD} = 2.7\text{ V}, I_{OL} = 20\text{ }\mu\text{A}$ at 30-pF load			0.1		
I_{OZ}	Off-state output current (high-impedance-state)	$V_O = V_{DD}$	$\overline{CS} = V_{DD}$	1		μA	
		$V_O = 0$		-1 -2.5			
I_{IH}	High-level input current	$V_I = V_{DD}$	0.005		2.5	μA	
I_{IL}	Low-level input current	$V_I = 0\text{ V}$	-0.005		2.5	μA	
I_{CC}	Operating supply current	\overline{CS} at 0 V	$V_{DD} = 4.5\text{ V to }5.5\text{ V}$	1.3		1.5	mA
			$V_{DD} = 2.7\text{ V to }3.3\text{ V}$	0.85		0.95	
$I_{CC}(\text{AUTOPWDN})$	Autopower-down current $t(\text{powerdown}) \geq 0.5\text{ }\mu\text{s}$	For all digital inputs, $0 \leq V_I \leq 0.3\text{ V}$ or $V_I \geq V_{DD} - 0.3\text{ V}$, SCLK = 0, $V_{DD} = 4.5\text{ V to }5.5\text{ V}$, Ext ref				5	μA
		$V_{DD} = 2.7\text{ V to }3.3\text{ V}$, Ext ref				2	
	Deep autopower-down current $t(\text{powerdown}) \geq 2\text{ ms}$	For all digital inputs, $0 \leq V_I \leq 0.3\text{ V}$ or $V_I \geq V_{DD} - 0.3\text{ V}$, SCLK = 0, $V_{DD} = 4.5\text{ V to }5.5\text{ V}$, Ext ref				1	μA
		$V_{DD} = 2.7\text{ V to }3.3\text{ V}$				1	
Selected analog input channel leakage current		Selected channel at V_{DD}				1	μA
		Selected channel at 0 V				-1	
C_i	Input capacitance	Analog inputs		20	45	50	pF
		Control Inputs		5		25	
Input on resistance		$V_{DD} = 5.5\text{ V}$				500	Ω
		$V_{DD} = 2.7\text{ V}$				600	
Autopower down				0.5		SCLK	

† All typical values are at $V_{DD} = 5\text{ V}$, $T_A = 25^\circ\text{C}$.



TLV2541, TLV2542, TLV2545
2.7-V TO 5.5-V, LOW-POWER, 12-BIT, 140/200 KSPS,
SERIAL ANALOG-TO-DIGITAL CONVERTERS WITH AUTOPOWER DOWN

SLAS245D – MARCH 2000 – REVISED MAY 2003

ac specifications (f_i = 20 kHz)

PARAMETER		TEST CONDITIONS	MIN	TYP	MAX	UNIT
SINAD	Signal-to-noise ratio +distortion	200 KSPS, V _{DD} = V _{REF} = 5.5 V	70	72		dB
		150 KSPS, V _{DD} = V _{REF} = 2.7 V	68	71		
THD	Total harmonic distortion	200 KSPS, V _{DD} = V _{REF} = 5.5 V		-84	-80	dB
		150 KSPS, V _{DD} = V _{REF} = 2.7 V		-84	-80	
ENOB	Effective number of bits	200 KSPS, V _{DD} = V _{REF} = 5.5 V		11.8		Bits
		150 KSPS, V _{DD} = V _{REF} = 2.7 V		11.6		
SFDR	Spurious free dynamic range	200 KSPS, V _{DD} = V _{REF} = 5.5 V		-84	-80	dB
		150 KSPS, V _{DD} = V _{REF} = 2.7 V		-84	-80	
Analog Input						
	Full-power bandwidth, -3 dB			1		MHz
	Full-power bandwidth, -1 dB			500		kHz

external reference specifications

PARAMETER		TEST CONDITIONS	MIN	TYP	MAX	UNIT
	Reference input voltage	V _{DD} = 2.7 V to 5.5 V	2		V _{DD}	V
Reference input impedance	V _{DD} = 5.5 V	$\overline{\text{CS}} = 1, \text{ SCLK} = 0$	100			MΩ
		$\overline{\text{CS}} = 0, \text{ SCLK} = 20 \text{ MHz}$	20	25		kΩ
	V _{DD} = 2.7 V	$\overline{\text{CS}} = 1, \text{ SCLK} = 0$	100			MΩ
		$\overline{\text{CS}} = 0, \text{ SCLK} = 20 \text{ MHz}$	20	25		kΩ
Reference current	V _{DD} = V _{REF} = 5.5 V, $\overline{\text{CS}} = 0, \text{ SCLK} = 20 \text{ MHz}$		100	400		μA
	V _{DD} = V _{REF} = 2.7 V, $\overline{\text{CS}} = 0, \text{ SCLK} = 20 \text{ MHz}$		50	200		
Reference input capacitance	V _{DD} = V _{REF} = 5.5 V	$\overline{\text{CS}} = 1, \text{ SCLK} = 0$	5		15	pF
		$\overline{\text{CS}} = 0, \text{ SCLK} = 20 \text{ MHz}$	20	45	50	
	V _{DD} = V _{REF} = 2.7 V	$\overline{\text{CS}} = 1, \text{ SCLK} = 0$	5		15	
		$\overline{\text{CS}} = 0, \text{ SCLK} = 20 \text{ MHz}$	20	45	50	
V _{REF}	Reference voltage	V _{DD} = 2.7 V to 5.5 V			V _{DD}	V

dc specification, V_{DD} = V_{REF} = 2.7 V to 5.5 V, SCLK frequency = 20 MHz at 5 V, 15 MHz at 3 V (unless otherwise noted)

PARAMETER		TEST CONDITIONS	MIN	TYP	MAX	UNIT
INL	Integral linearity error (see Note 4)			±0.6	±1	LSB
DNL	Differential linearity error	See Note 3		±0.5	±1	LSB
E _O	Offset error (see Note 5)	See Note 3	TLV2541/42		±1.5	LSB
			TLV2545		±2.5	
E _G	Gain error (see Note 5)	See Note 3	TLV2541/42		±2	LSB
			TLV2545		±5	
E _t	Total unadjusted error (see Note 6)	See Note 3	TLV2541/42		±2	LSB
			TLV2545		±5	

- NOTES: 3. Analog input voltages greater than that applied to V_{REF} convert as all ones (111111111111).
4. Linear error is the maximum deviation from the best straight line through the A/D transfer characteristics.
5. Zero error is the difference between 000000000000 and the converted output for zero input voltage: full-scale error is the difference between 111111111111 and the converted output for full-scale input voltage.
6. Total unadjusted error comprises linearity, zero, and full-scale errors.



TLV2541, TLV2542, TLV2545
2.7-V TO 5.5-V, LOW-POWER, 12-BIT, 140/200 KSPS,
SERIAL ANALOG-TO-DIGITAL CONVERTERS WITH AUTOPOWER DOWN
 SLAS245D – MARCH 2000 – REVISED MAY 2003

PARAMETER MEASUREMENT INFORMATION

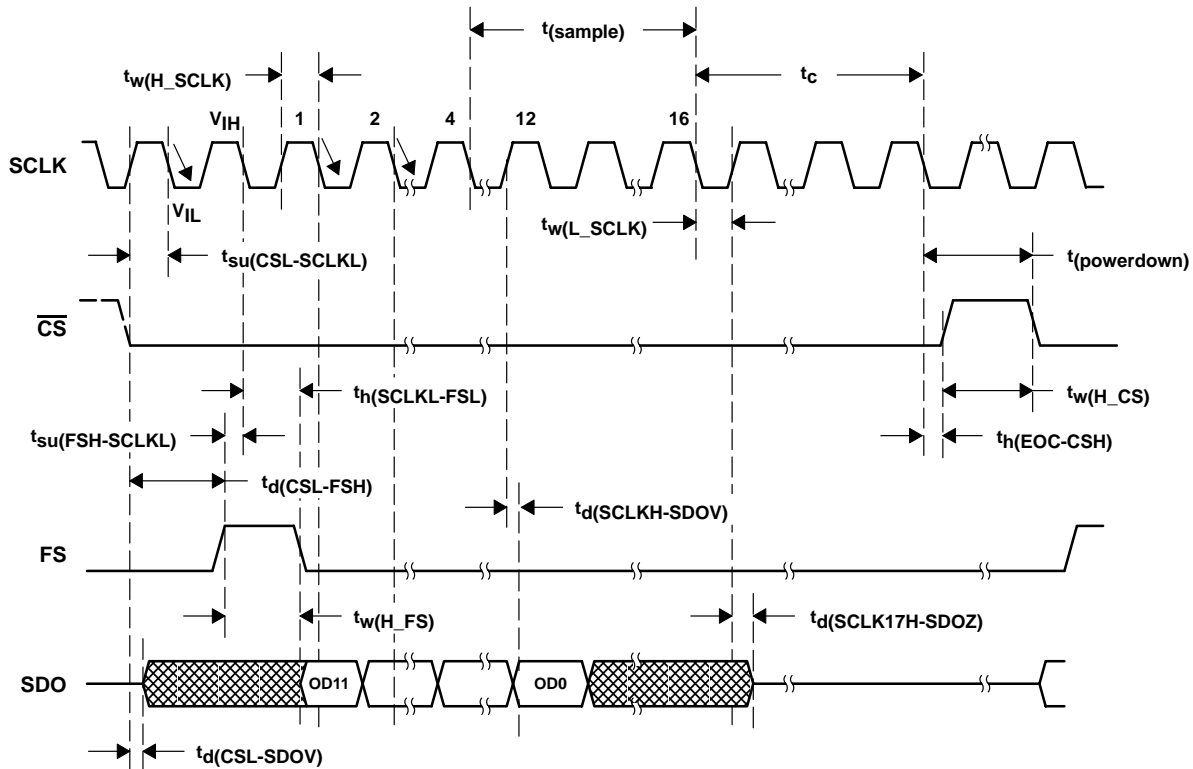

Figure 6. TLV2541 Critical Timing (Control via \overline{CS} and FS or FS only)

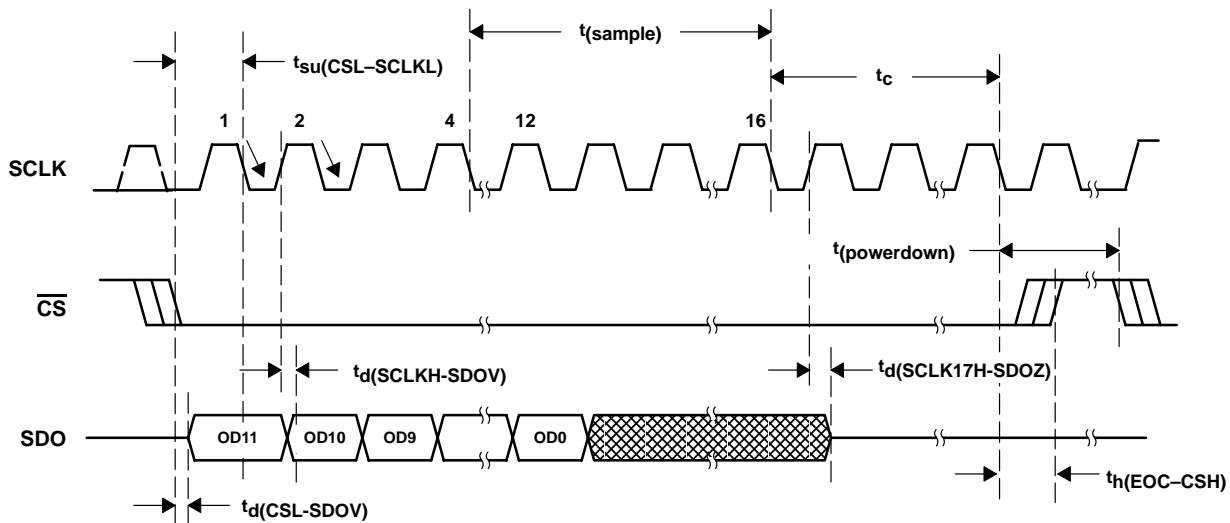

Figure 7. TLV2541 Critical Timing (Control via \overline{CS} only, FS = 1)



PARAMETER MEASUREMENT INFORMATION

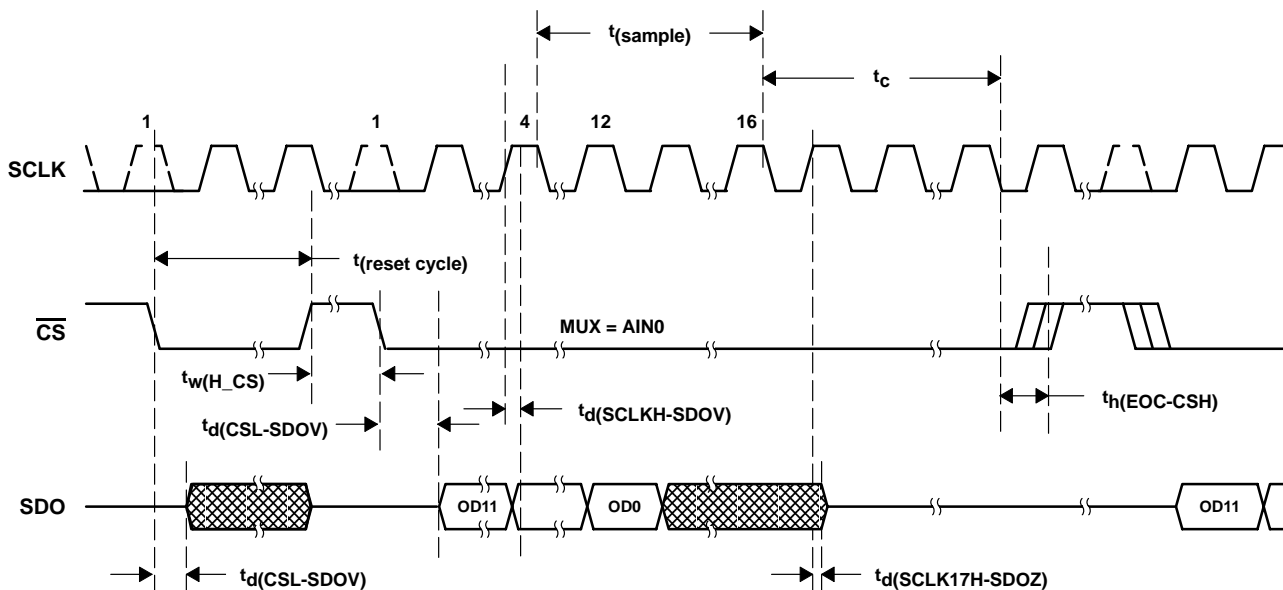

Figure 8. TLV2542 Reset Cycle Critical Timing

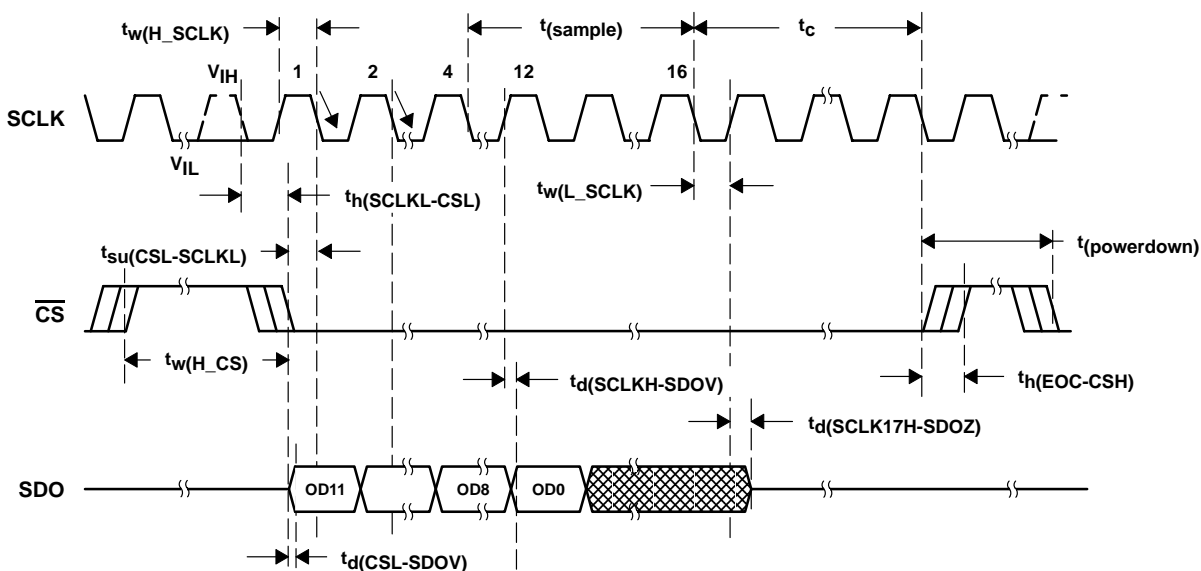

Figure 9. TLV2542 and TLV2545 Conversion Cycle Critical Timing

TYPICAL CHARACTERISTICS

INTEGRAL NONLINEARITY
 vs
 FREE-AIR TEMPERATURE

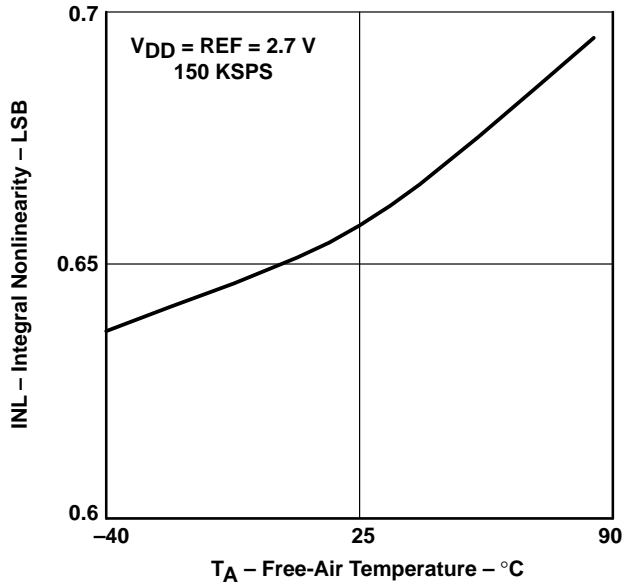

Figure 10

INTEGRAL NONLINEARITY
 vs
 FREE-AIR TEMPERATURE

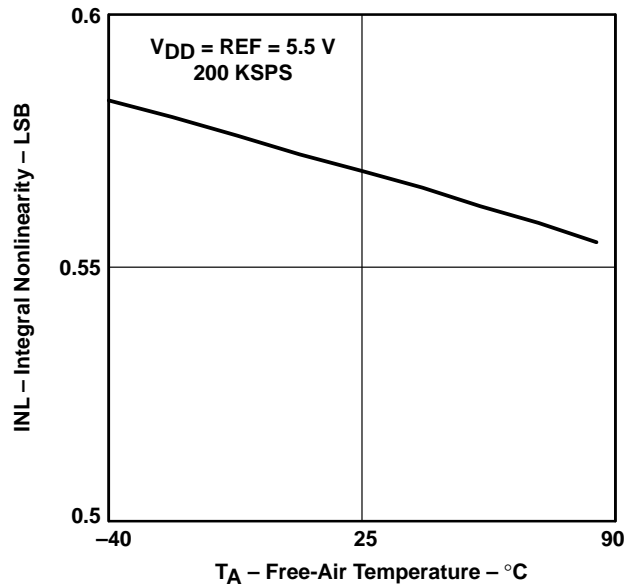

Figure 11

DIFFERENTIAL NONLINEARITY
 vs
 FREE-AIR TEMPERATURE

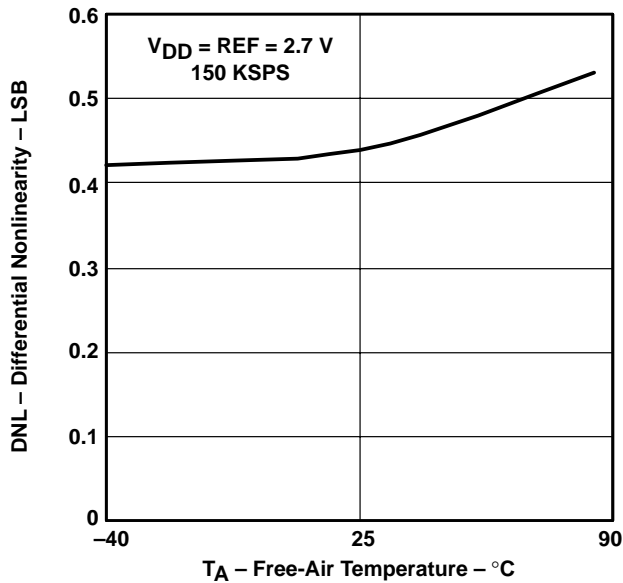

Figure 12

DIFFERENTIAL NONLINEARITY
 vs
 FREE-AIR TEMPERATURE

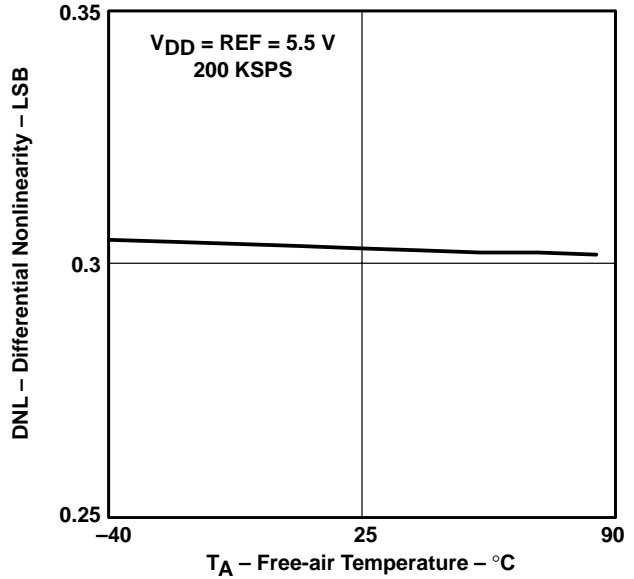

Figure 13

TYPICAL CHARACTERISTICS

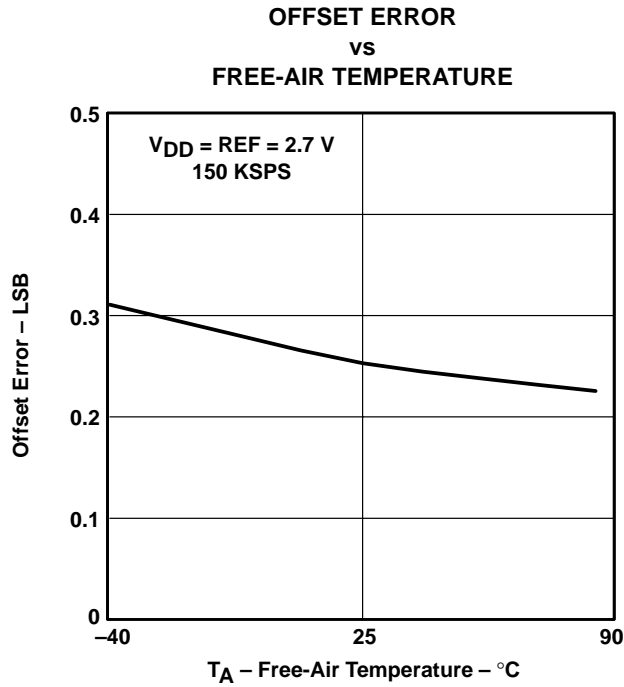

Figure 14

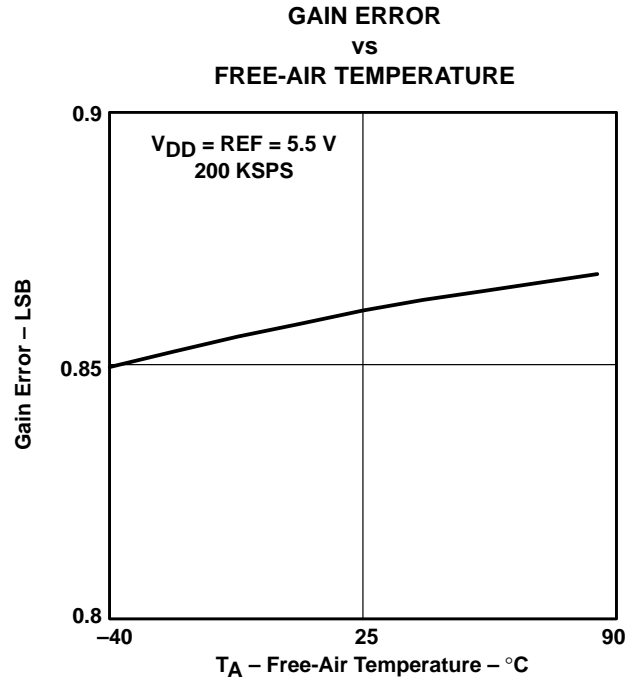

Figure 15

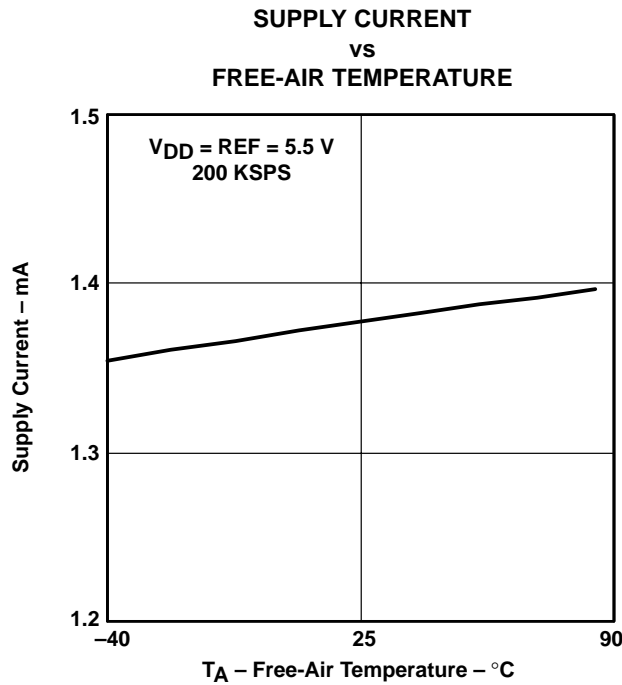

Figure 16

TYPICAL CHARACTERISTICS

INTEGRAL NONLINEARITY ERROR
vs
DIGITAL OUTPUT CODES

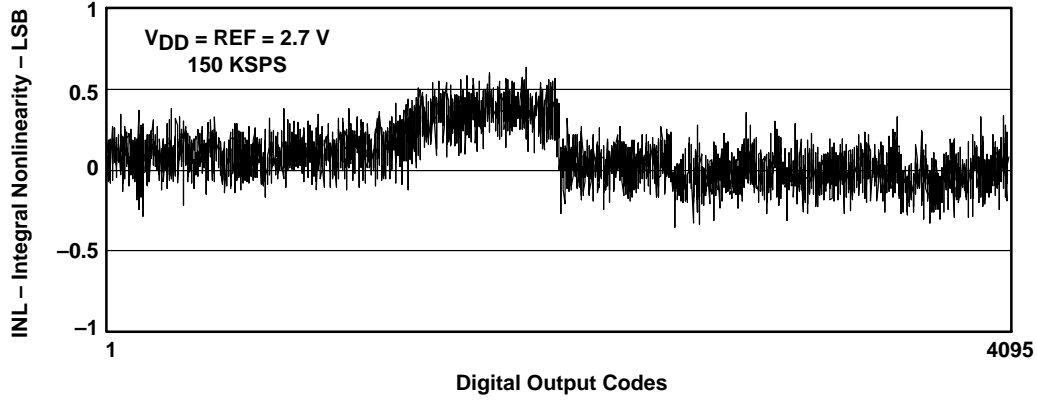

Figure 17

DIFFERENTIAL NONLINEARITY ERROR
vs
DIGITAL OUTPUT CODES

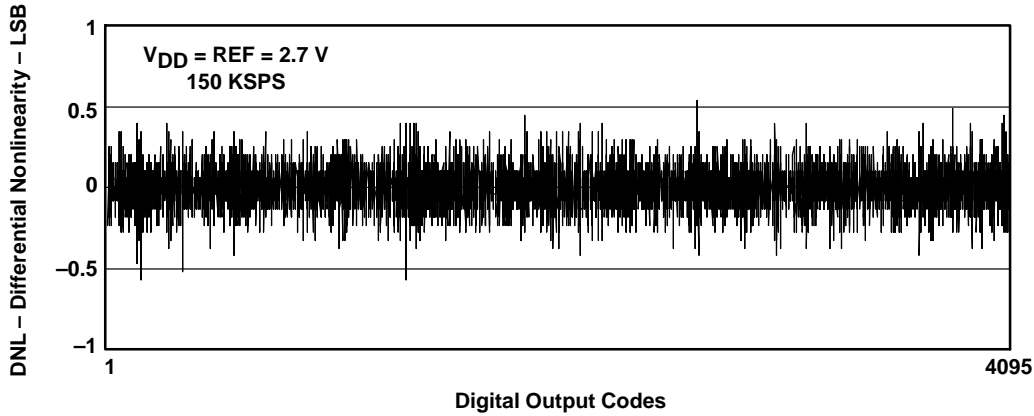

Figure 18

TYPICAL CHARACTERISTICS

INTEGRAL NONLINEARITY ERROR
vs
DIGITAL OUTPUT CODES

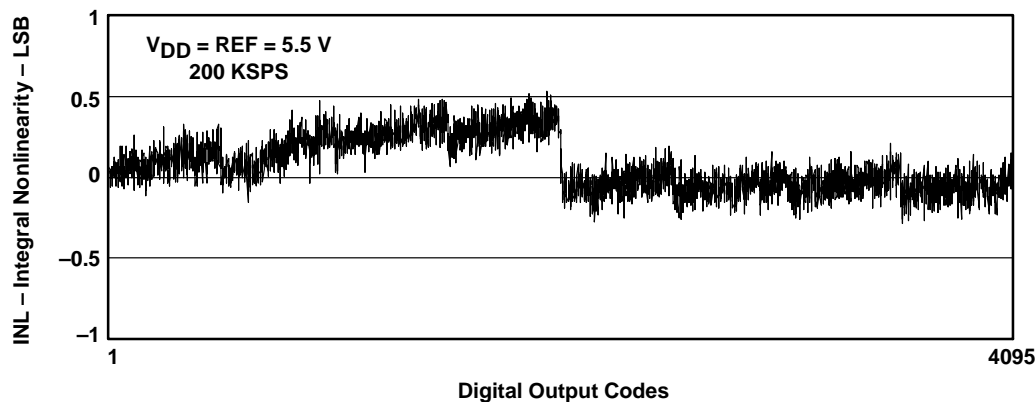

Figure 19

DIFFERENTIAL NONLINEARITY ERROR
vs
DIGITAL OUTPUT CODES

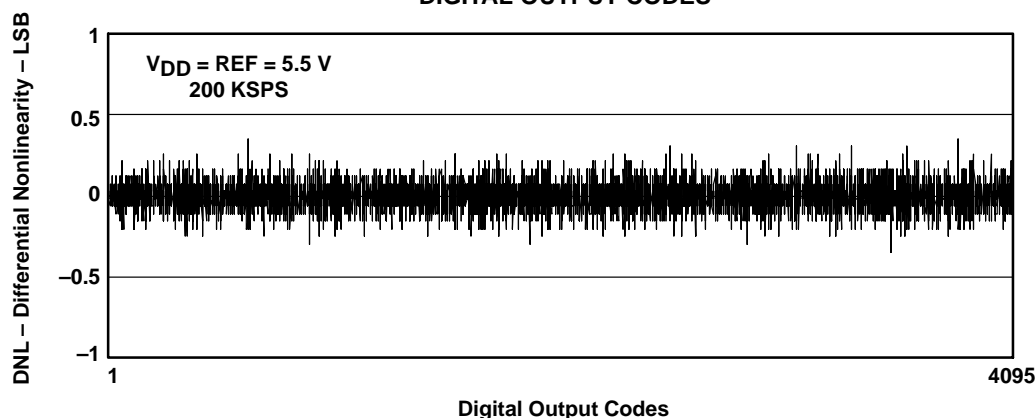

Figure 20

TYPICAL CHARACTERISTICS

2048 POINTS FAST FOURIER TRANSFORM (FFT)

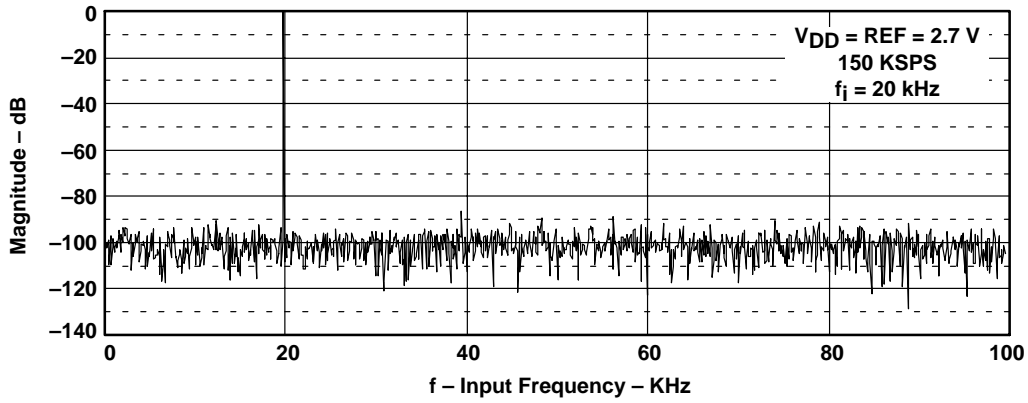

Figure 21

2048 POINTS FAST FOURIER TRANSFORM (FFT)

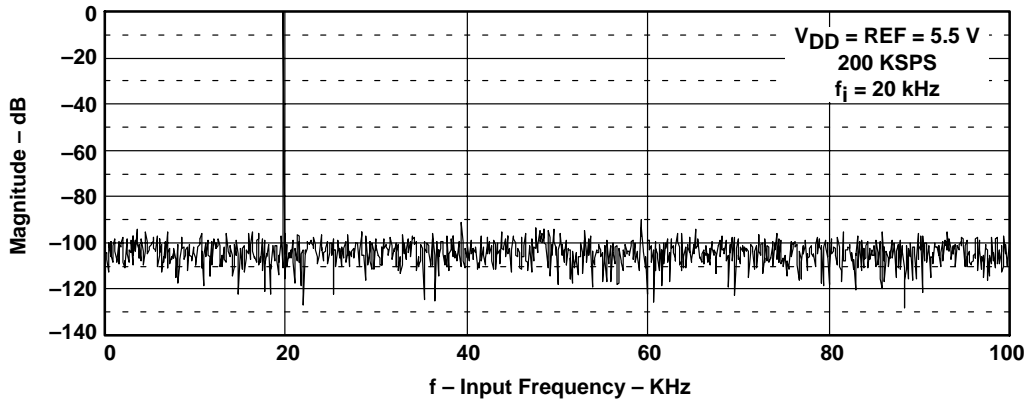

Figure 22

TYPICAL CHARACTERISTICS

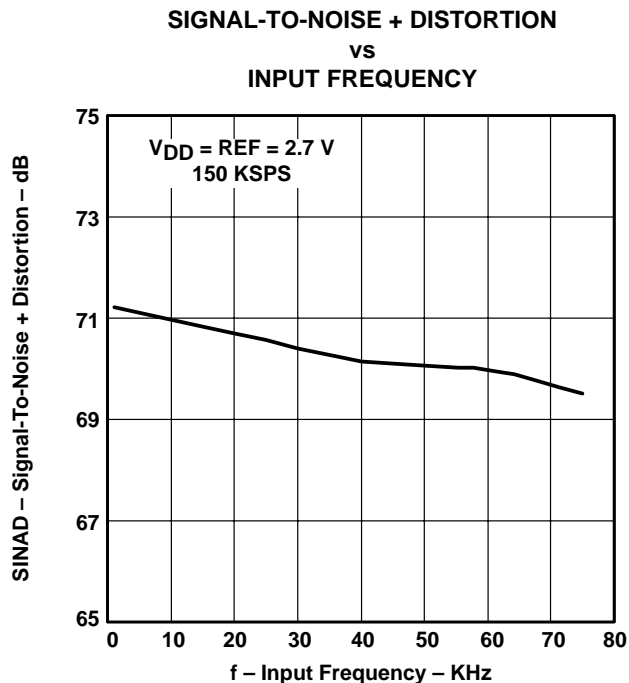

Figure 23

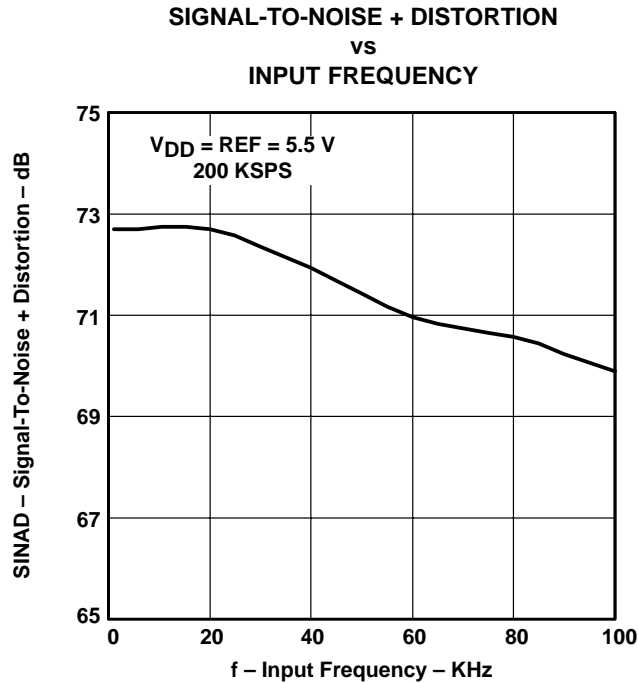

Figure 24

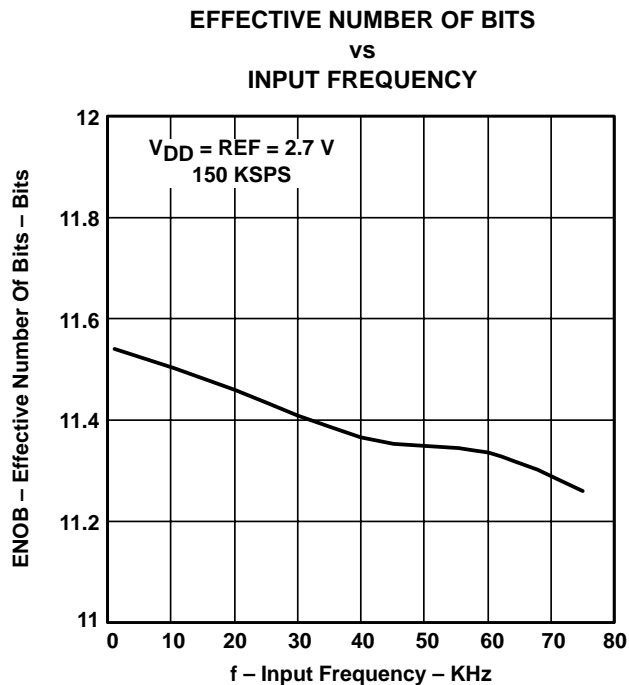

Figure 25

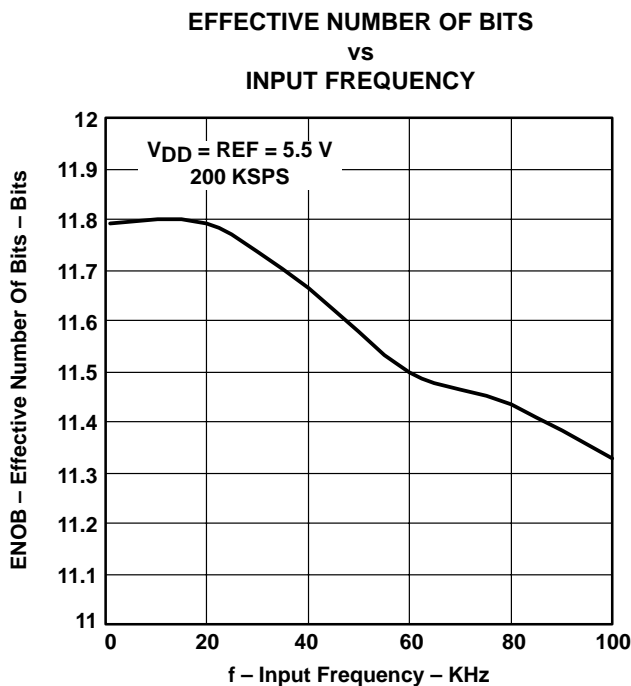

Figure 26

TYPICAL CHARACTERISTICS

**TOTAL HARMONIC DISTORTION
 vs
 INPUT FREQUENCY**

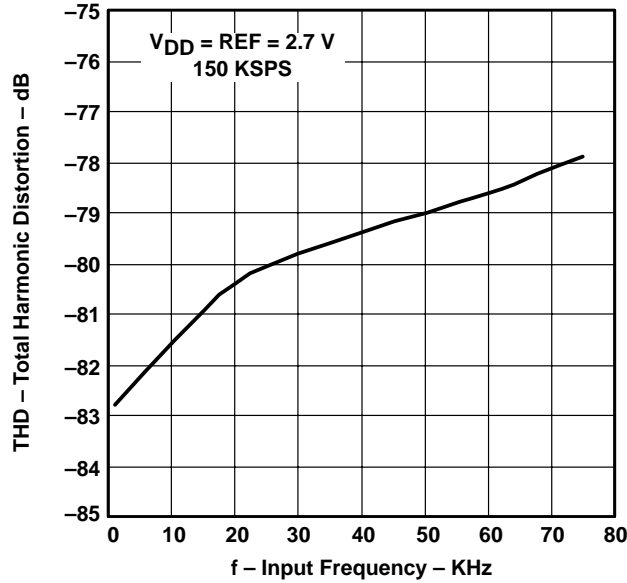

Figure 27

**TOTAL HARMONIC DISTORTION
 vs
 INPUT FREQUENCY**

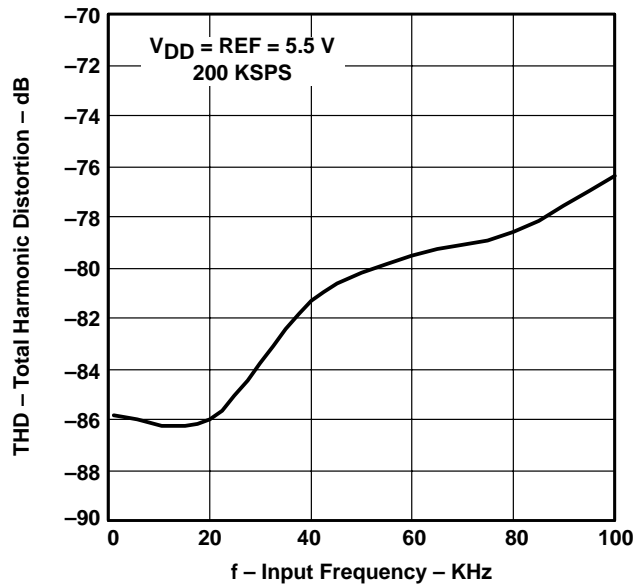
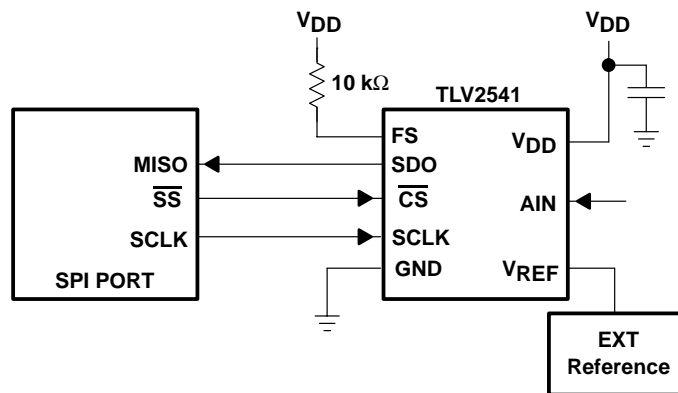
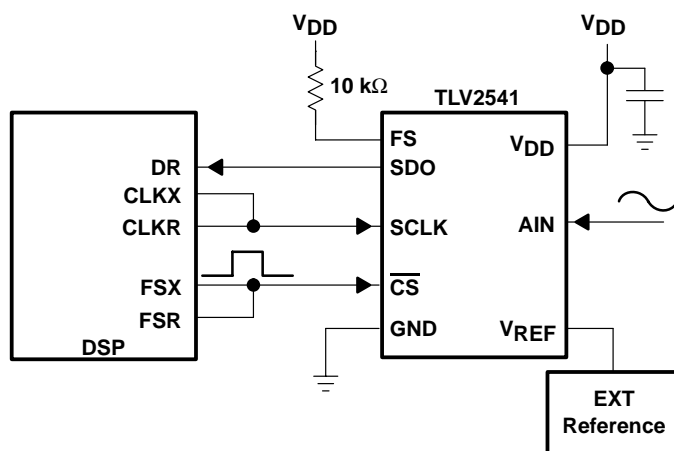

Figure 28

APPLICATION INFORMATION



(a)



(b)

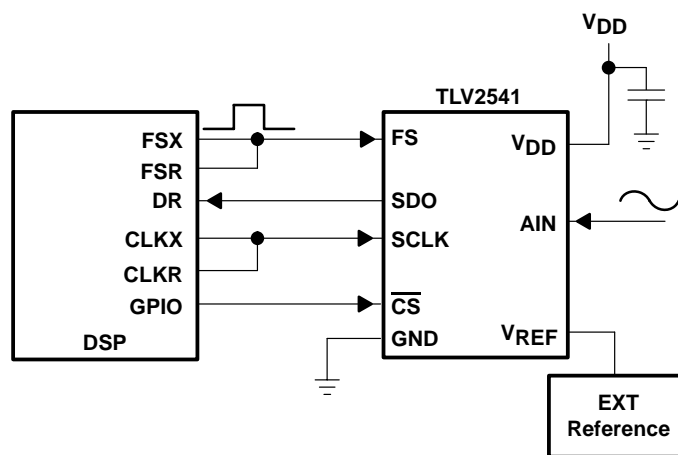

(c)

Figure 29. Typical TLV2541 Interface to a TMS320 DSP

APPLICATION INFORMATION

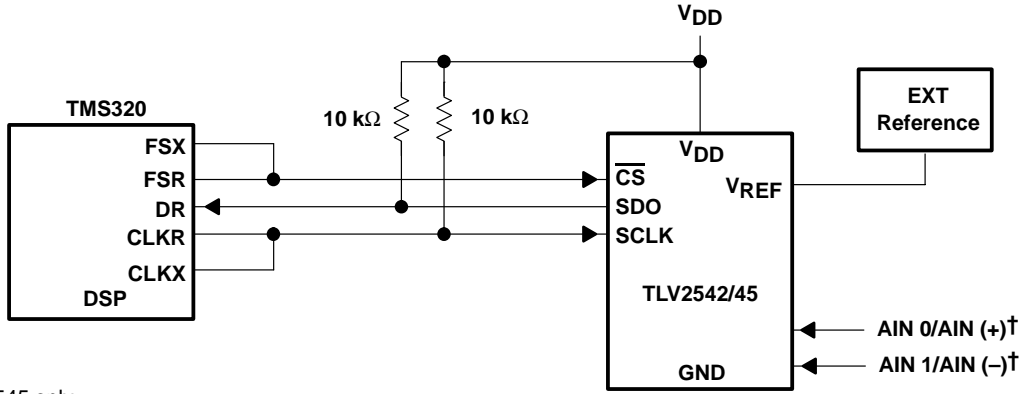

† For TLV2545 only

Figure 30. Typical TLV2542/45 Interface to a TMS320 DSP

IMPORTANT NOTICE

Texas Instruments Incorporated and its subsidiaries (TI) reserve the right to make corrections, modifications, enhancements, improvements, and other changes to its products and services at any time and to discontinue any product or service without notice. Customers should obtain the latest relevant information before placing orders and should verify that such information is current and complete. All products are sold subject to TI's terms and conditions of sale supplied at the time of order acknowledgment.

TI warrants performance of its hardware products to the specifications applicable at the time of sale in accordance with TI's standard warranty. Testing and other quality control techniques are used to the extent TI deems necessary to support this warranty. Except where mandated by government requirements, testing of all parameters of each product is not necessarily performed.

TI assumes no liability for applications assistance or customer product design. Customers are responsible for their products and applications using TI components. To minimize the risks associated with customer products and applications, customers should provide adequate design and operating safeguards.

TI does not warrant or represent that any license, either express or implied, is granted under any TI patent right, copyright, mask work right, or other TI intellectual property right relating to any combination, machine, or process in which TI products or services are used. Information published by TI regarding third-party products or services does not constitute a license from TI to use such products or services or a warranty or endorsement thereof. Use of such information may require a license from a third party under the patents or other intellectual property of the third party, or a license from TI under the patents or other intellectual property of TI.

Reproduction of information in TI data books or data sheets is permissible only if reproduction is without alteration and is accompanied by all associated warranties, conditions, limitations, and notices. Reproduction of this information with alteration is an unfair and deceptive business practice. TI is not responsible or liable for such altered documentation.

Resale of TI products or services with statements different from or beyond the parameters stated by TI for that product or service voids all express and any implied warranties for the associated TI product or service and is an unfair and deceptive business practice. TI is not responsible or liable for any such statements.

Following are URLs where you can obtain information on other Texas Instruments products and application solutions:

Products		Applications	
Amplifiers	amplifier.ti.com	Audio	www.ti.com/audio
Data Converters	dataconverter.ti.com	Automotive	www.ti.com/automotive
DSP	dsp.ti.com	Broadband	www.ti.com/broadband
Interface	interface.ti.com	Digital Control	www.ti.com/digitalcontrol
Logic	logic.ti.com	Military	www.ti.com/military
Power Mgmt	power.ti.com	Optical Networking	www.ti.com/opticalnetwork
Microcontrollers	microcontroller.ti.com	Security	www.ti.com/security
		Telephony	www.ti.com/telephony
		Video & Imaging	www.ti.com/video
		Wireless	www.ti.com/wireless

Mailing Address: Texas Instruments
Post Office Box 655303 Dallas, Texas 75265

Copyright © 2003, Texas Instruments Incorporated