

Constant-current driver

for small LCD panel back light

(Non-boost type)

BD1754HFN



- General Description

The multi-level brightness control LED works as a constant current driver in 64 steps, so that the driving current can be adjusted finely. BD1754HFN is best suited to turn on LEDs that require high-accuracy LED brightness control.

- Features

- 1) Current regulation for LED up to 4 parallels
- 2) Adjustable constant current 64 steps
- 3) High accurate and matching of each current channel (0.5% Typ)
- 4) Brightness control via a signal-line digital control interface (Uni-Port Interface Control = UPIC)
- 5) 2.9 mm x 3.0 mm HSON8 Small package

- Application

This driver is applicable for various fields such as mobile phones, portable game machines and etc.

● Absolute Maximum Ratings (Ta = 25 °C)

Parameter	Symbol	Limits	Unit
Maximum applied voltage	VMAX	7	V
Power dissipation	Pd	630 (*1)	mW
Operating temperature range	Topr	-30 ~ +85	°C
Storage temperature range	Tstg	-55 ~ +150	°C

(*1) This value is the measurement value when the driver is mounted on a glass epoxy board (70 mm x 70 mm x 1.6 mm).
When using the driver at Ta of 25 °C or higher, the power is dissipated by approx. 5.04 mW/°C.

● Recommended Operating Conditions (Ta = -30 °C to +85 °C)

Parameter	Symbol	Limits			Unit	Condition
		Min	Typ	Max		
Operating power supply voltage	Vin	2.7	3.6	5.5	V	
Driver pin voltage range	VDRV	0.2	-	Vin-1.4	V	When Current driver power on.

● Electrical Characteristics

(Unless otherwise specified, Ta = 25 °C and Vin = 3.6 V)

Parameter	Symbol	Limits			Parameter	Symbol
		Min	Typ	Max		
Quiescent current	Iq	-	0.1	1	µA	EN=0V
Circuit current	IDD	-	1.2	2.0	mA	Except LED current
[Current driver]						
Maximum current	ILED-max	29.76	32.0	34.24	mA	R _{ISSET} = 120kΩ
LED Current accuracy	ILED-diff	-	-	7.0	%	When current 16.5 mA setting R _{ISSET} = 120kΩ
LED Current matching	ILED-match	-	0.5	3.0*1	%	When current 16.5 mA setting R _{ISSET} = 120kΩ
[Logic controller]						
Low threshold voltage	VIL	-	-	0.4	V	
High threshold voltage	VIH	1.4	-	-	V	
'H' level input current	I _{IH}	-	0	2	µA	EN=Vin
'L' level input current	I _{IL}	-2	0	-	µA	EN=0V
EN 'H' time	THI	0.05	-	100	µsec	
EN 'L' time	TLO	0.3	-	100	µsec	
EN Off time-out	TOFF	1	-	-	msec	
VIN supply -> EN active time	TVINON	1	-	-	msec	
EN stand-by -> VBAT Off time	TVINOFF	0	-	-	msec	

*1) The following expression is used for calculation:

$$I_{LED-match} = \{(I_{max} - I_{min}) / (I_{max} + I_{min})\} \times 100$$

I_{max} = Current value in a channel with the maximum current value among all channels

I_{min} = Current value in a channel with the minimum current value among all channels

● Reference Data

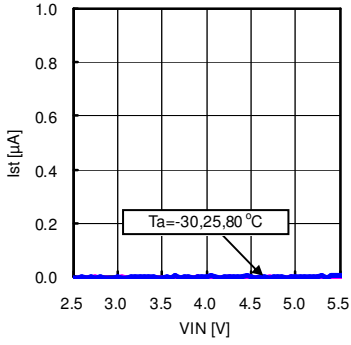

Fig. 1 Circuit current (stand-by)

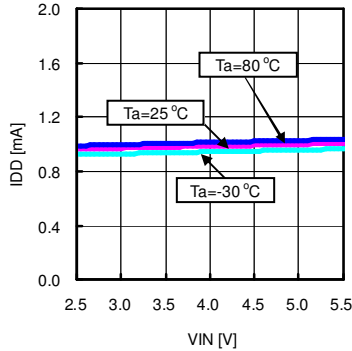

Fig. 2 Circuit current

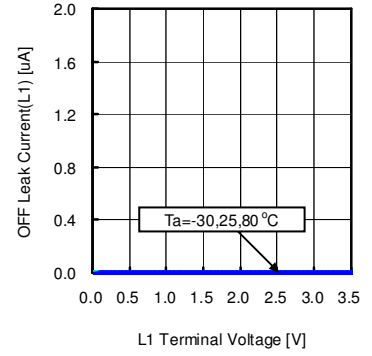

Fig. 3 LED off-leakage current

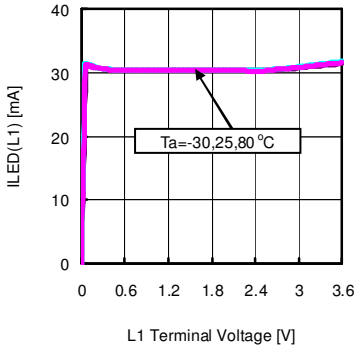

Fig. 4 LED output current vs. LED pin voltage
(Vin = 3.6 V, at 32 mA of LED current)

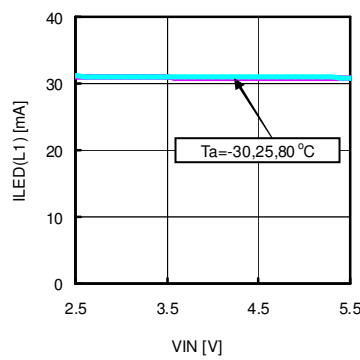

Fig. 5 LED output current vs. VIN
(Vin = 3.6 V, at 32 mA of LED current)

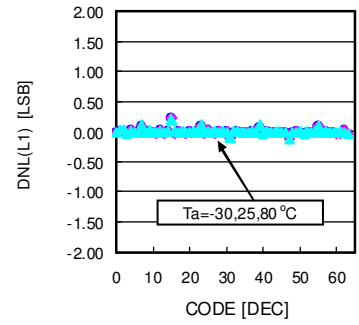

Fig. 6 LED current characteristics
(Vin = 3.6 V, differential linearity error)

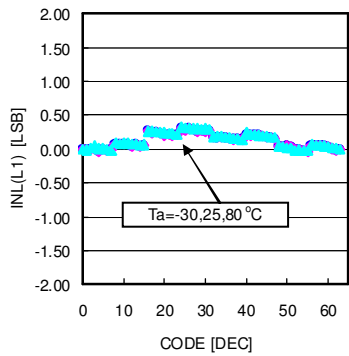

Fig. 7 LED current characteristics
(Vin = 3.6 V, integral linearity error)

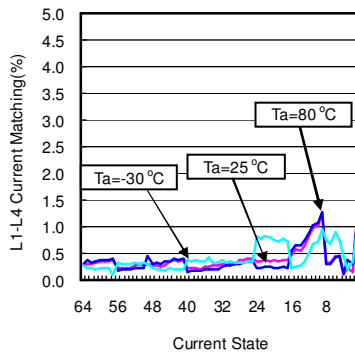

Fig. 8 LED current relative accuracy
(Vin = 3.6 V)

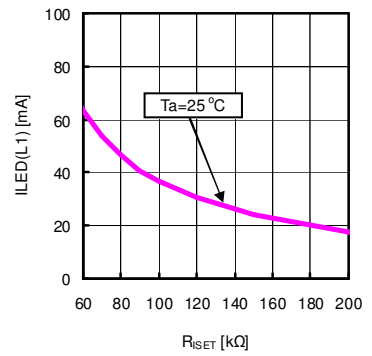

Fig. 9 LED current vs. R_{ISET}
(Vin = 3.6 V, at the maximum current setting)

● Block Diagram and Recommended Circuit Example

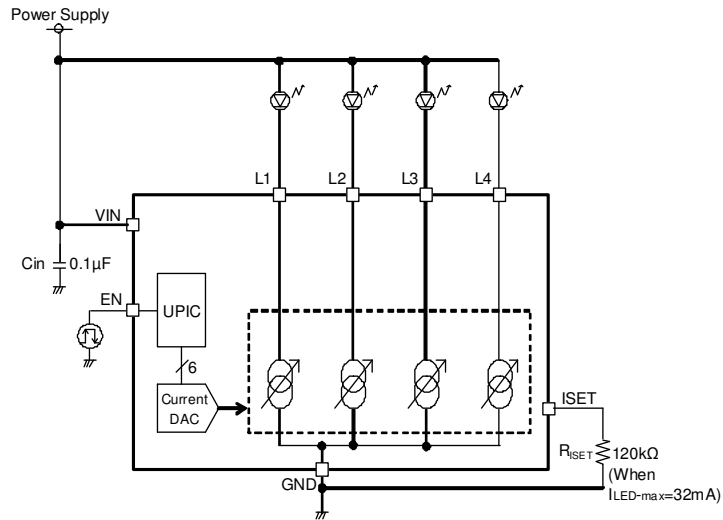

Fig.10 BD1754HFN Block Diagram and Recommended Circuit Example

● Terminals

No.	Pin Name	In/ Out	ESD Diode		Functions
			For Power	For GND	
1	EN	In	VIN	GND	LED enable and Brightness control signal
2	GND	-	VIN	-	Ground
3	ISET	Out	VIN	GND	Bias current
4	VIN	-	-	GND	Power supply voltage input
5	L1	Out	-	GND	Current sink for LED 1
6	L2	Out	-	GND	Current sink for LED 2
7	L3	Out	-	GND	Current sink for LED 3
8	L4	Out	-	GND	Current sink for LED 4

● Description of Operations

(1) UPIC (= Uni-Port Interface Control) interface

BD1754HFN has a single-line digital control interface (UPIC) that can control the power ON/OFF and LED current value through the EN pin only. The LED current decreases by one step depending on the number of rising edges. After the number of rising edge is reached to the minimum output current (64 rising edges), the next rising edge changes the output current to the maximum value at startup time. To maintain any output current, the EN pin must be kept at 'H' level. To power off, the EN pin must be kept at 'L' level for more than 1 msec.

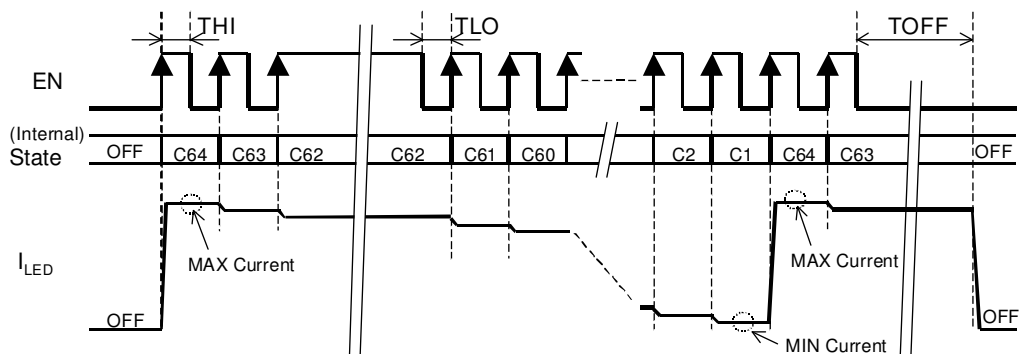

Fig. 11 Brightness Control Method

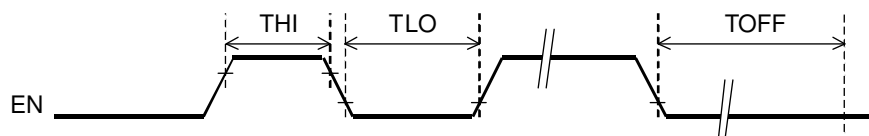

Fig. 12 UPIC Interface

By following sequence, UPIC can control current driver for MAX current and OFF state only.

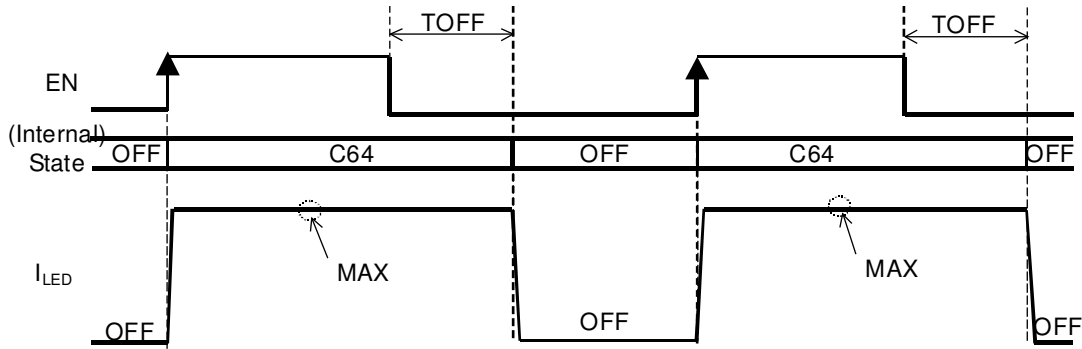

Fig. 13 UPIC Interface usage for MAX current or OFF only

(2) Current Driver

The MAX Current is determined by the ISET resistance and the following expression.

$$I_{LED-MAX} [mA] = 6.4 \times 600 [mV] / R_{ISET} [k\Omega]$$

The LED current state can be changed by the EN control signal. When the state is Cn, the output current (I_{LED}) can be obtained from the following expression (where, n indicates a state number).

$$I_{LED} [mA] = I_{LED-MAX} \times n / 64$$

The following table is the example of LED current, when ISET resistance is 120 [kΩ].

R_{ISET} : 120[kΩ]

State	Output current [mA]	State	Output current [mA]	State	Output current [mA]	State	Output current [mA]
C64	32.0	C48	24.0	C32	16.0	C16	8.0
C63	31.5	C47	23.5	C31	15.5	C15	7.5
C62	31.0	C46	23.0	C30	15.0	C14	7.0
C61	30.5	C45	22.5	C29	14.5	C13	6.5
C60	30.0	C44	22.0	C28	14.0	C12	6.0
C59	29.5	C43	21.5	C27	13.5	C11	5.5
C58	29.0	C42	21.0	C26	13.0	C10	5.0
C57	28.5	C41	20.5	C25	12.5	C9	4.5
C56	28.0	C40	20.0	C24	12.0	C8	4.0
C55	27.5	C39	19.5	C23	11.5	C7	3.5
C54	27.0	C38	19.0	C22	11.0	C6	3.0
C53	26.5	C37	18.5	C21	10.5	C5	2.5
C52	26.0	C36	18.0	C20	10.0	C4	2.0
C51	25.5	C35	17.5	C19	9.5	C3	1.5
C50	25.0	C34	17.0	C18	9.0	C2	1.0
C49	24.5	C33	16.5	C17	8.5	C1	0.5

When the state is C64 (the maximum value), the output current value can be changed on the ISET resistance value as below.

State : C64

ISET resistance value (kΩ)	Output current per channel (mA)	Total output current of the four channels (mA)
240	16.0	64.0
120	32.0	128.0
90	42.7	170.8
60	64.0	256.0

● Application Circuit Examples

(1) Circuit example when the power supply is separated

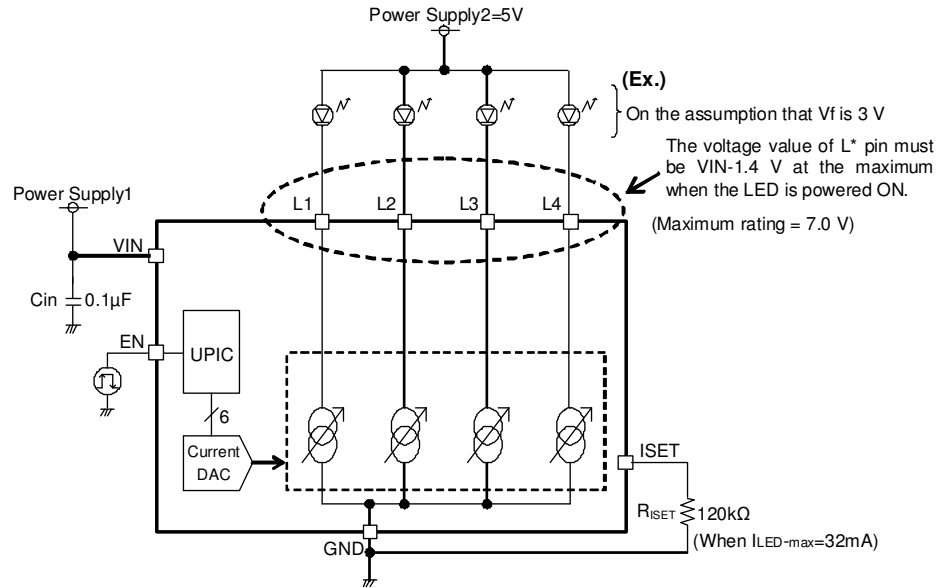

Fig.14 Circuit example when the power supply is separated

This figure shows a circuit example when the power supply for VIN and for LEDs is separated. Apply a voltage of V_f (threshold voltage value of a white LED) or higher to the LED.

In this time, it is necessary to note that, when the LED is powered ON, the voltage value of L^* pin (each pin of L1 to L4) must be $V_{IN}-1.4$ V at the maximum. If a voltage of higher than $V_{IN}-1.4$ V is applied to L^* pin, a desired current value cannot be obtained. Also, it is necessary to pay attention to the voltage application procedure at start-up. Be sure to power the current driver ON using the UPIC after applying power supply voltages to the VIN and the LED-anode pins. If the current driver is powered ON prior to applying power supply voltages to the LED, a rush current occurs in the LED.

Determine the resistance value with which the LED current value is maximized and then connect such resistor between the ISET and the GND pins. The power ON/OFF and the brightness of the LEDs are controlled through the EN pin in accordance with the UPIC format.

(2) Circuit example when using only two LEDs

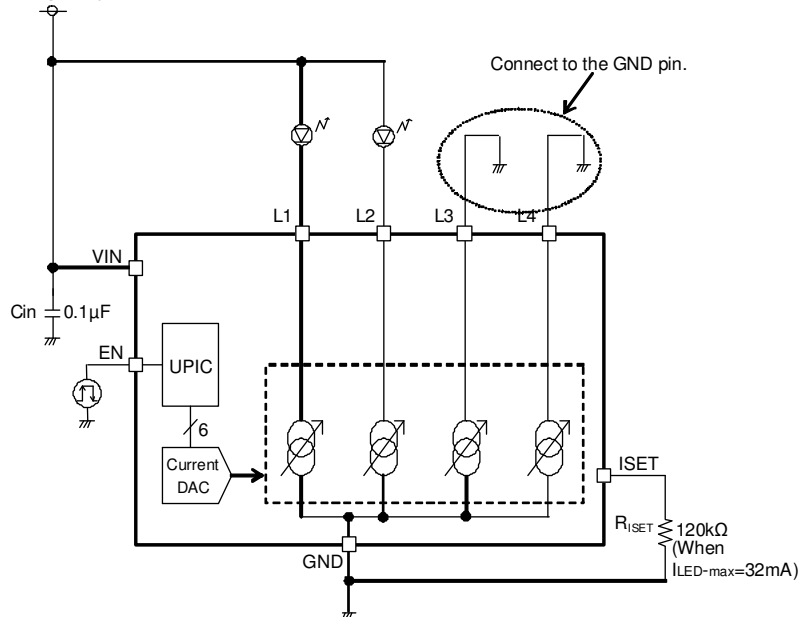

Fig.15 Circuit example when using only two LEDs

This figure shows a circuit example when both of the L3 and L4 LEDs are not used. Connect both of the unused L3 and L4 pins to the GND pin. Likewise, it is possible to make the L1 and/or the L2 pins unused, which allows the back lights to be used with the one or three LED(s) turned on. In all cases, connect the unused L^* pin to the GND pin.

Determine the resistance value with which the LED current value is maximized and then connect such resistor between the ISET and the GND pins. The power ON/OFF and the brightness of the LEDs are controlled through the EN pin in accordance with the UPIC format.

(3) Circuit example when the EN pin is powered on at all times

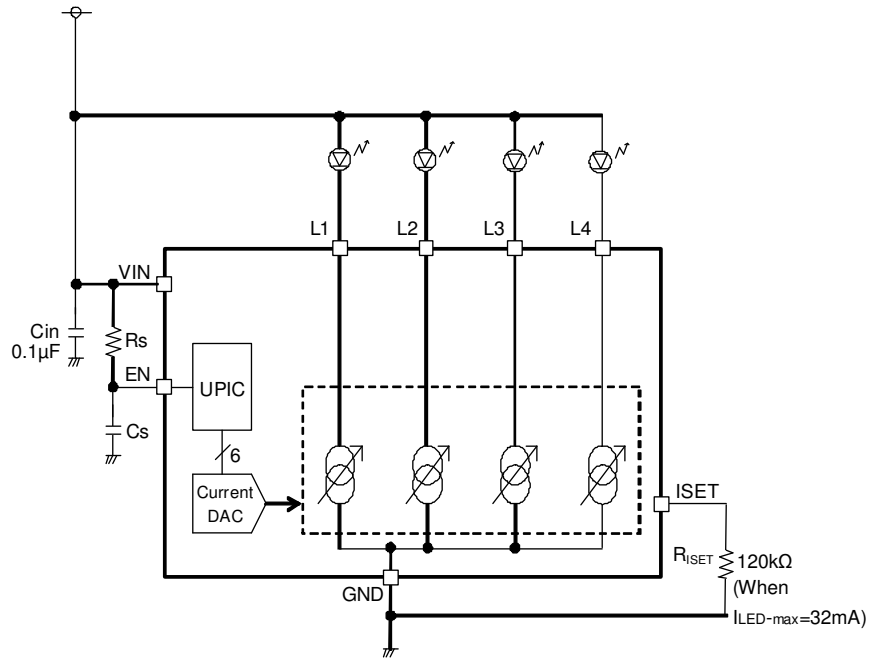

Fig.16 Circuit example when the EN pin is powered on at all times

This figure shows a circuit example when the EN pin is powered on at all times. To prevent a rush current from occurring in the driver, it is necessary to apply voltages to the VIN pin and the LEDs prior to powering the current driver ON. Mount an RC filter between the VIN and the EN pins to delay the EN pin rising against the power-supply voltage rising. Determine the resistance value with which the LED current value is maximized and then connect such resistor between the ISET and the GND pins.

(4) Circuit example when performing a PWM brightness control

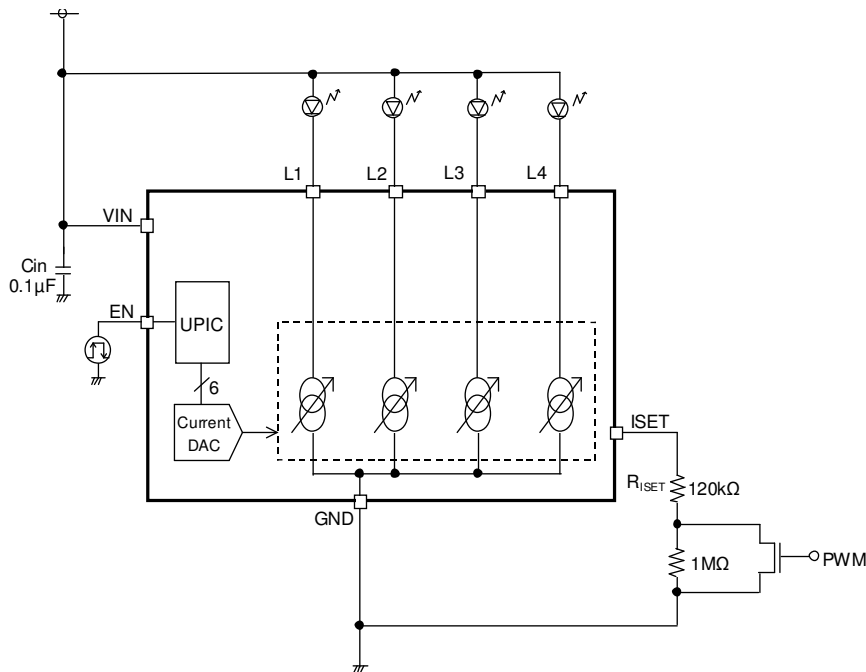

Fig.17 Circuit example when performing a PWM brightness control

This figure shows a circuit example when performing a PWM brightness control. Through switching the ISET resistance value by the PWM input signal, the LED current is outputted under a PWM mode. The EN signal is controlled by an applied voltage level. In the circuit example shown above, the LED current value is changed to 3.43 mA in 0 % of the PWM duty cycle, 17.72 mA in 50 % of that and 32 mA in 100 % of that.

(5) Circuit example when driving a large current with only one LED powered on.

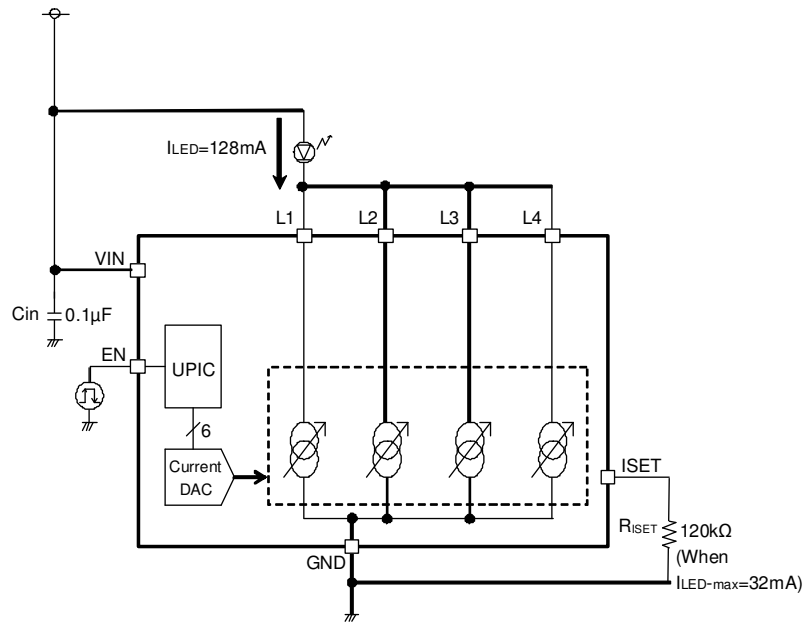

Fig.18 Circuit example when driving a large current with only one LED powered on.

This figure shows a circuit example when driving a large current through all the four channels with only one LED powered on. By shorting out all the LED driver pins, in the example of using 120 kΩ R_{ISET} , a current up to 128 mA ($32\text{ mA} \times 4$) can be driven. In this example, the brightness can be adjusted in 64 gradations with 2 mA step (0.5 mA step/channel \times 4 channels). For higher current values, using 60 kΩ R_{ISET} allows a current up to 256 mA to be driven into one of the LEDs. The power ON/OFF and the brightness of the LEDs are controlled through the EN pin in accordance with the UPIC format.

(6) Circuit example when making the eight LEDs available by connecting the two BD1754HFN drivers

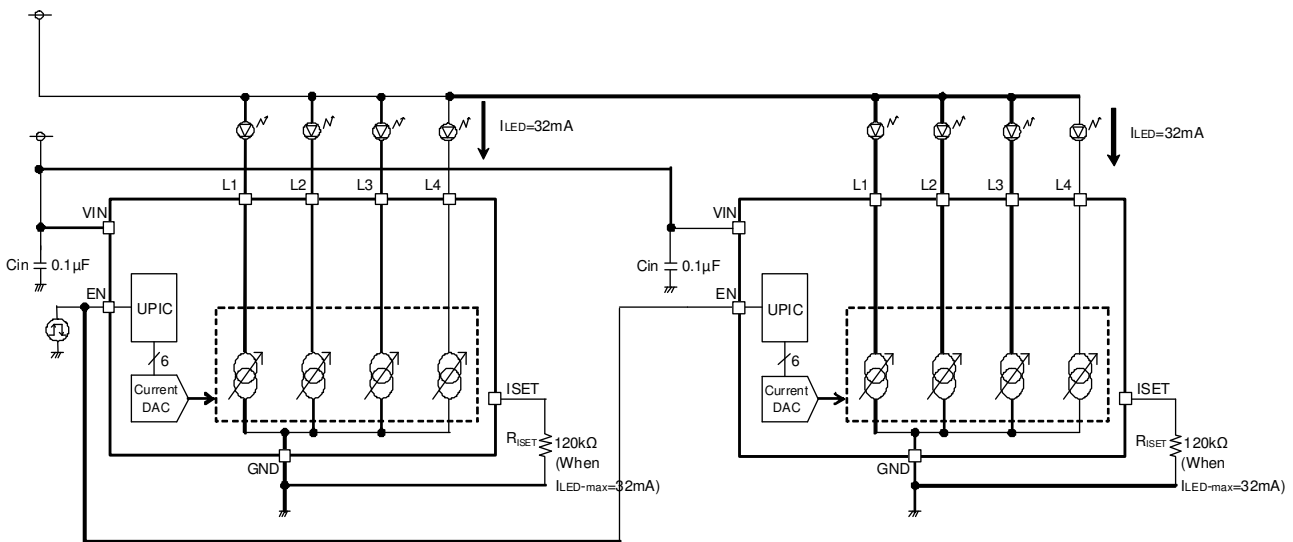

Fig.19 Circuit example when making the eight LEDs available by connecting the two BD1754HFN drivers

This figure shows a circuit example when making the eight LEDs available by connecting the two BD1754HFN drivers. By connecting the control signals to the EN pins in parallel, the eight LED channels can be controlled concurrently. This parallel connection can increase the number of the LED channels further as necessary (such as twelve, sixteen, or more). Determine the resistance value with which the LED current value is maximized and then connect such resistor between the ISET and the GND pins. The power ON/OFF and the brightness of the LEDs are controlled through the EN pin in accordance with the UPIC format.

(7) Circuit example when connecting the two LEDs to each of the channels in series

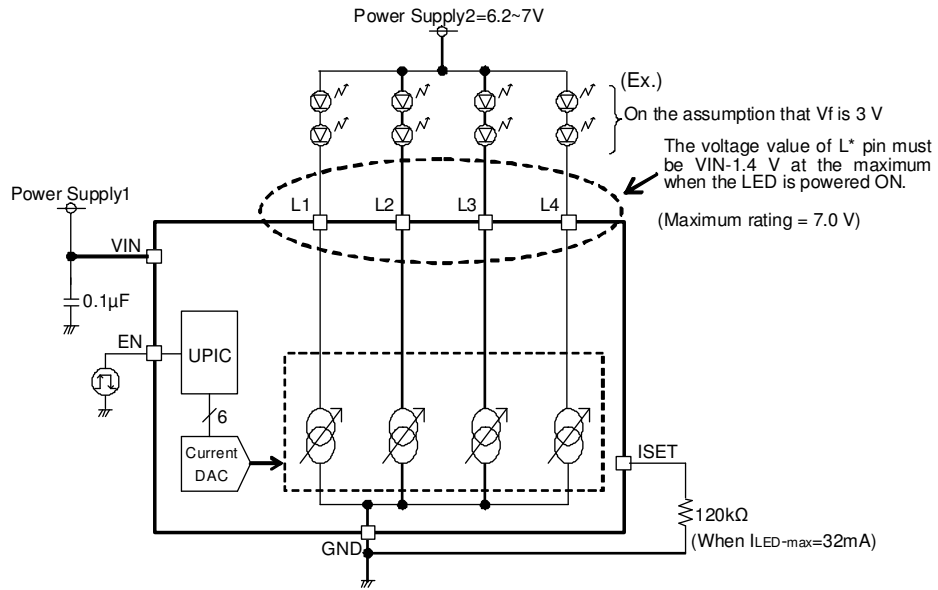

Fig.20 Circuit example when connecting the two LEDs to each of the channels in series

This figure shows a circuit example when making the 8(2 x 4) LEDs available by connecting the two LEDs to each of the channels in series. In this example, when V_f is set to approx. 3 V in order to ensure the voltage to the L1 to the L4 pin, it is necessary to apply a voltage of 6.2 V (3 V x 2 LEDs in series + 0.2 V of the minimum voltage value of the driver pin) or higher to the LED anode pin as its power supply voltage. Pay attention that the voltage should not exceed the 7.0-V maximum rating of the L1 to the L4 pin. Determine the resistance value with which the LED current value is maximized and then connect such resistor between the ISET and the GND pins. The power ON/OFF and the brightness of the LEDs are controlled through the EN pin in accordance with the UPIC format.

● Application Component Selection

<Capacitor>

Symbol	Recommended value	Recommended component	Manufacturer
C _{in}	0.1µF	GRM188B31H104KA92B	MURATA

<Resistor>

Symbol	Recommended value	Recommended component	Manufacturer
R _{ISET}	120kΩ	MCR10PZHZF1203	ROHM

● Recommended PCB Layout

Design PCB pattern to provide low impedance for the wiring to the power supply line. Also, provide a bypass condenser if needed.

Connect C_{in} input-bypass capacitor in close proximity between the VIN and GND pins. Connect the R_{ISET} resistor in close proximity to the ISET pin.

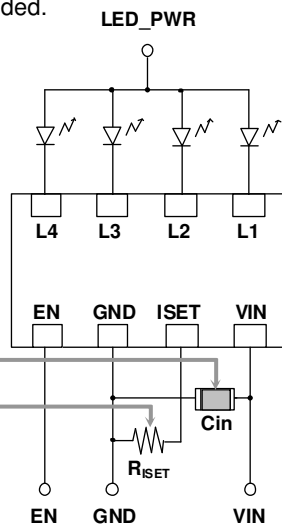

Fig. 21 Layout image of the application components (Top View)

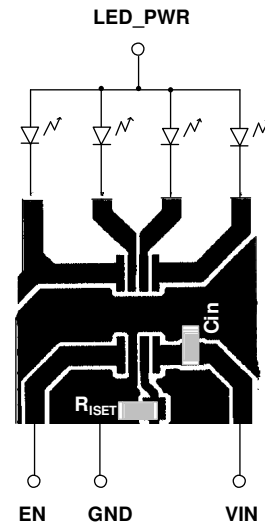

Fig. 22 Surface (Top View)

● Cautions on Use

(1) Absolute Maximum Ratings

An excess in the absolute maximum ratings, such as applied voltage, temperature range of operating conditions, can break down devices, thus making impossible to identify breaking mode such as a short circuit or an open circuit. If any special mode exceeding the absolute maximum ratings is assumed, consideration should be given to take physical safety measures including the use of fuses, etc.

(2) Recommended Operating Conditions

These conditions represent a range within which characteristics can be provided approximately as expected. The electrical characteristics are guaranteed under the conditions of each parameter. The voltage and temperature characteristics are also shown under the conditions in respect of electrical ones.

(3) Reverse connection of power supply connector

The reverse connection of power supply connector can break down ICs. Take protective measures against the breakdown due to the reverse connection, such as mounting an external diode between the power supply and the IC's power supply terminal.

(4) Power supply line

Design PCB pattern to provide low impedance for the wiring between the power supply and the GND lines. Furthermore, for all power supply terminals to ICs, mount a capacitor between the power supply and the GND terminal. At the same time, in order to use an electrolytic capacitor, thoroughly check to be sure that the characteristics of the capacitor to be used present no problem including the occurrence of capacity dropout at a low temperature, thus determining the constant.

(5) GND voltage

Make setting of the potential of the GND terminal so that it will be maintained at the minimum in any operating state. Furthermore, check to be sure that no terminal is operated at a potential lower than the GND voltage including an actual electric transient.

(6) Short circuit between terminals and erroneous mounting

In order to mount ICs on a set PCB, pay thorough attention to the direction and offset of the ICs. Erroneous mounting can break down the ICs. Furthermore, if a short circuit occurs due to foreign matters entering between terminals or between the terminal and the power supply or the GND terminal, the ICs can break down.

(7) Operation in strong electromagnetic field

Be noted that using ICs in the strong electromagnetic field can cause a malfunction.

(8) Inspection with set PCB

On the inspection with the set PCB, if a capacitor is connected to a low-impedance IC terminal, the IC can suffer stress. Therefore, be sure to discharge from the set PCB by each process. Furthermore, in order to mount or dismount the set PCB to/from the jig for the inspection process, be sure to turn OFF the power supply and then mount the set PCB to the jig. After the completion of the inspection, be sure to turn OFF the power supply and then dismount it from the jig. In addition, for protection against static electricity, establish a ground for the assembly process and pay thorough attention to the transportation and the storage of the set PCB.

(9) Input terminals

In terms of the construction of IC, parasitic elements are inevitably formed in relation to potential. The operation of the parasitic element can cause interference with circuit operation, thus resulting in a malfunction and then breakdown of the input terminal. Therefore, pay thorough attention not to handle the input terminals, such as to apply to the input terminals a voltage lower than that applied to the GND respectively, so that any parasitic element will operate. Furthermore, do not apply a voltage to the input terminals when no power supply voltage is applied to the IC. In addition, even if the power supply voltage is applied, apply to the input terminals a voltage lower than the power supply voltage or within the guaranteed value of electrical characteristics.

(10) Ground wiring pattern

If small-signal GND and large-current GND are provided, it will be recommended to separate the large-current GND pattern from the small-signal GND pattern and establish a single ground at the reference point of the set PCB so that resistance to the wiring pattern and voltage fluctuations due to a large current will cause no fluctuations in voltages of the small-signal GND. Pay attention not to cause fluctuations in the GND wiring pattern of external parts as well.

(11) Thermal design

Perform thermal design in which there are adequate margins by taking into account the permissible dissipation (Pd) in actual states of use.

ご注意

- 記載内容は2006年2月現在のものです。
- 記載内容は改良のためお断りなしに変更することがあります。ご使用の際には情報が最新のものであることをご確認下さい。
- 記載されております応用回路例やその定数などの情報につきましては、本製品の標準的な動作や使い方を説明するものです。従いまして、量産設計をされる場合には、外部諸条件を考慮していただきますようお願いいたします。
- ここに記載されております製品に関する応用回路例、情報、諸データは、あくまで一例を示すものであり、これらに関します第三者の工業所有権等の知的財産権、及びその他の権利に対して、権利侵害がないことの保証を示すものではありません。従いまして (1) 上記第三者の知的財産権の侵害の責任、又は、(2) これらの製品の使用により発生する責任につきましては弊社は、その責を負いかねますのでご了承ください。
- 本カタログに記載されている製品の販売に関し、その製品自体の使用、販売、その他の処分以外には弊社の所有または管理している工業所有権など知的財産権またはその他のあらゆる権利について明示的にも黙視的にも、その実施または利用を主に許諾するものではありません。
- 本品は、特定の機器・装置用として特別に設計された専用品とみなされるため、その機器・装置が外為法に定める規制貨物に該当するか否かを判断していただく必要があります。
- 本製品は「シリコン」を主材料として製造されております。
- 本製品は「耐放射線設計」はなされております。

本カタログに掲載されている製品は、一般的な電子機器（AV機器、OA機器、通信機器、家電製品、アミューズメント機器など）への使用を意図しています。極めて高度な信頼性が要求され、その製品の故障や誤動作が直接人命に関わるような機器・装置（医療機器、輸送機器、航空宇宙機、原子力制御、燃料制御、各種安全装置など）へのご使用を検討される際は、事前に弊社営業窓口までご相談願います。

エレクトロニクスで社会に貢献する

ROHM

ローム株式会社

本社/〒615-8585 京都市右京区西院溝崎町21
TEL(075)311-2121 FAX(075)315-0172
URL <http://www.rohm.co.jp/>

東日本営業本部

本部・横浜 〒222-8575 横浜市港北区新横浜2-4-8
TEL: (045)476-2290 FAX: (045)476-2295

西日本営業本部

本部・京都 〒600-8216 京都市下京区塩小路通烏丸西入東塩小路町579-32
TEL: (075)365-1077 FAX: (075)365-1079

<ビジネスセンター>

大宮 〒330-0854 埼玉県さいたま市大宮区桜木町1-10-16
シーノ大宮ノースウイング15階
TEL: (048)650-8521 FAX: (048)650-8525

八重洲 〒104-0028 東京都中央区八重洲2-1-1
TEL: (03)5203-0321 FAX: (03)5203-0300

品川 〒108-6110 東京都港区港南2-15-2
品川インターシティB棟10階
TEL: (03)5783-7310 FAX: (03)5783-7315

横浜 〒222-8575 横浜市港北区新横浜2-4-8
TEL: (045)476-2290 FAX: (045)476-2295

名古屋

〒450-0002 名古屋市中村区名駅3-28-12 大名古屋ビル10階
TEL: (052)581-8521 FAX: (052)561-2173

京都

〒600-8216 京都市下京区塩小路通烏丸西入東塩小路町579-32
TEL: (075)365-1077 FAX: (075)365-1079

新大阪

〒532-0003 大阪府大阪市淀川区宮原3-5-36
新大阪MTビル2号館6階

TEL: (06)6396-8567 FAX: (06)6396-8576

神戸

〒650-0001 兵庫県神戸市中央区加納町4-4-17
ニッセイ三宮ビル12階
TEL: (078)927-8510 FAX: (078)327-8512

アジア営業本部

本部・京都 〒600-8216 京都市下京区塩小路通烏丸西入東塩小路町579-32
TEL: (075)365-1216 FAX: (075)365-1226

欧米営業本部

本部・京都 〒600-8216 京都市下京区塩小路通烏丸西入東塩小路町579-32
TEL: (075)365-1218 FAX: (075)365-1228

カタログ No.05T931A 06.2 ROHM©1600 TSU