

THIS DRAWING IS UNPUBLISHED. RELEASED FOR PUBLICATION, 19 .
 © COPYRIGHT 19 BY AMP INCORPORATED. ALL INTERNATIONAL RIGHTS RESERVED.

LOC	DIST	P	F	REVISIONS				
G	14			ZONE	LTR	DESCRIPTION	DATE	APPD
					L	REV / 0720-0380-94	6/1/94	ME

AMP WIRE RANGE	Listed FILE E13288	LR7189 Certified
16-14 AWG SOLID OR STRANDED	16-14 AWG SOLID OR STRANDED	16-14 AWG SOLID OR STRANDED

METRIC
 DIMENSIONS LISTED IN mm [INCHES]

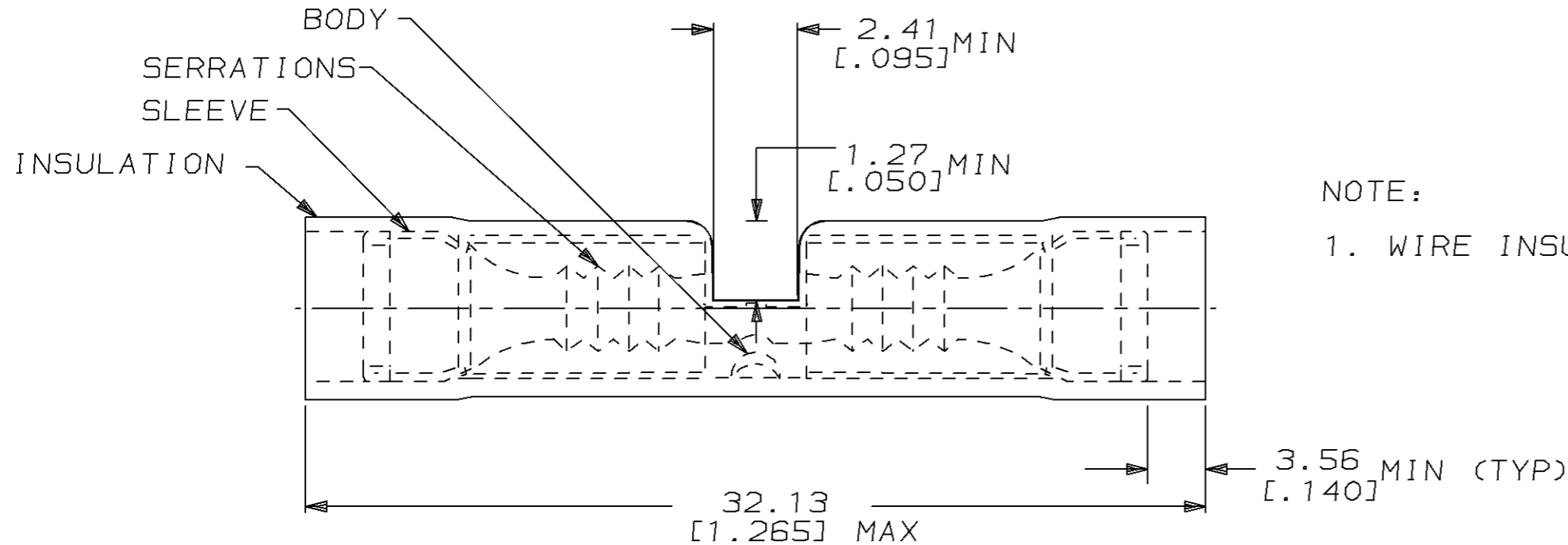

NOTE:
 1. WIRE INSULATION DIA 2.67 [.105] TO 3.81 [.150]

-	100	LOOSE PIECE, BOX	8-320562-5
-	5	LOOSE PIECE, BLS	8-320562-4
-	50	LOOSE PIECE, BOX	8-320562-2
M7928/5-4 CLASS 2	2500	ON TAPE	2-320562-3
M7928/5-4 CLASS 1 & 2	50	LOOSE PIECE	320562
MILITARY PART NUMBER & CLASS PER MIL-T-7928	QTY	PACKAGE TYPE	PART NO

AMP INCORPORATED
CUSTOMER SERVICE SYSTEMS

FOR ADDITIONAL PRODUCT INFORMATION OR COPIES OF DRAWINGS AND TECHNICAL DOCUMENTS	PRODUCT INFORMATION CENTER 1-800-522-6752
FOR APPLICATION TOOLING INFORMATION	TOOLING ASSISTANCE CENTER 1-800-722-1111
FOR ORDER ENTRY	1-800-526-5142

MAX RECOMMENDED OPERATING TEMPERATURE:
 105°C

VOLTAGE RATING:
 600V MAX
 1000 V MAX (FIXTURE OR SIGN)

CIRCULAR MIL AREA:
 1.04-2.62 mm² [2,050-5,180]

SOLID OR STRANDED

DO NOT SCALE PRINT, UNLESS SPECIFIED
 DIMENSIONS IN mm [INCHES]
 TOLERANCES ON:
 2 PLC DEC ± 0.20 [.008]
 3 PLC DEC ± -
 ANGLES ± -

MATERIAL:
 COPPER PER ASTM B-152
 NYLON, COLOR: BLUE

FINISH:
 TIN PLATE
 PER MIL-T-10727

AMP AMP Incorporated
 Harrisburg, PA 17105-3608

NAME:
 SPLICE, BUTT, P.I.D.G.,
 WIRE SIZE: 16-14 AWG

SIZE	CAGE CODE	DRAWING NO
B	00779	C-320562
SCALE	NTS	SHEET
		1 OF 1