

NOTES:  
 1. WHEN MACHINE OR I PLATES MODIFICATIONS ARE REQUIRED,  
 USE THE CENTER OF THE BOX TO DIMENSION.

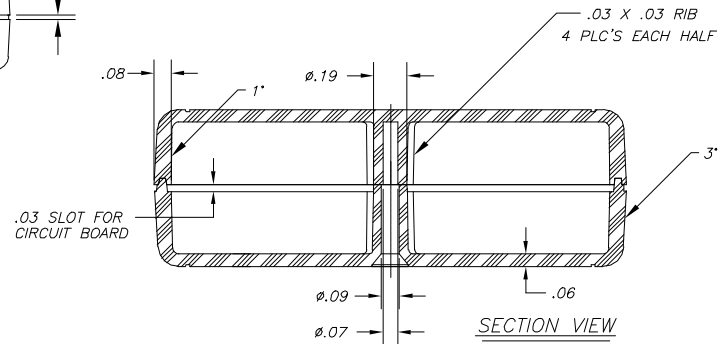
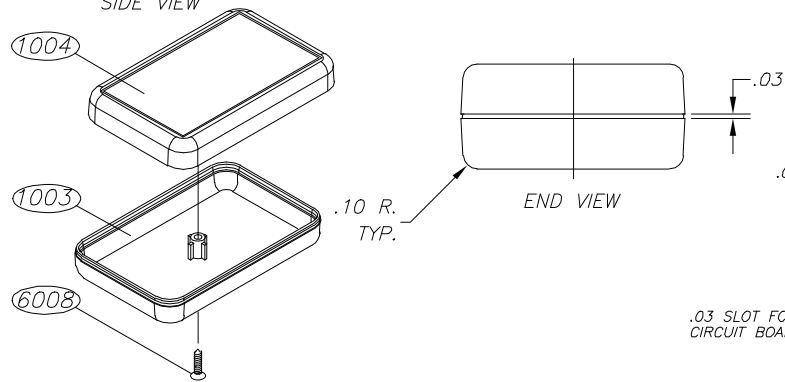
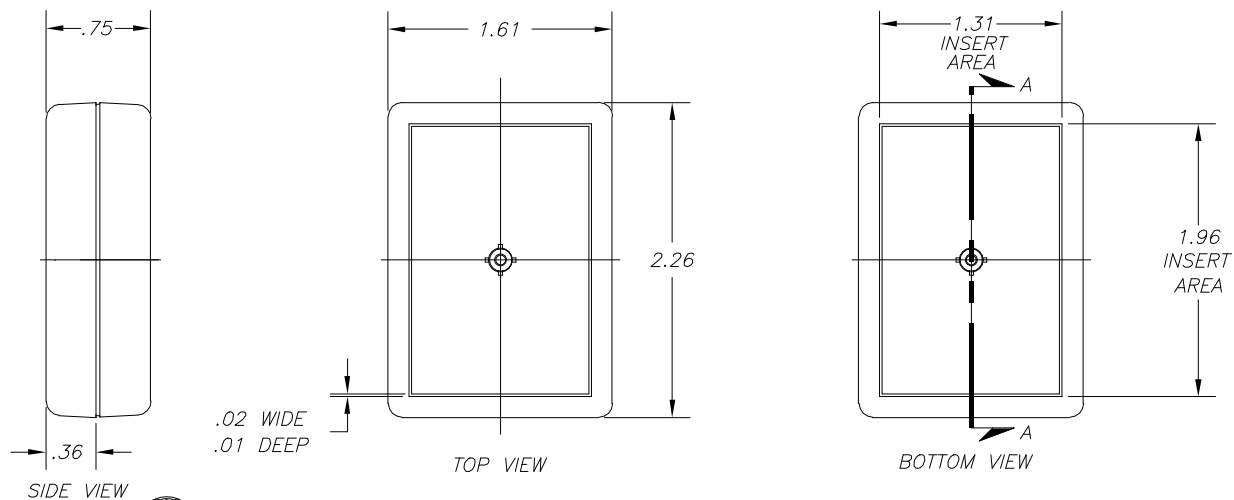

10-13-98 ALL DIMENSIONS  $\pm .010$

PART NO.	DESCRIPTION	ACCESSORIES	
1004	PLASTIC TOP	PART NO.	DESCRIPTION
1003	PLASTIC BOTTOM	55	KEY HOLDER
6008	SCREW	1030	POCKET CLIP