

# AC 3E



## SIZE :

80x80x38mm (3.15"x3.15"x1.50")

## CONSTRUCTION :

- All metal
- Die-cast aluminum housing
- Metal impeller
- Shaded pole motor
- Impedance protected
- Leader wire available

## OPERATING TEMPERATURE :

Ball bearing - 30°C to +75°C  
Sleeve bearing - 10°C to +70°C

## WEIGHT :

420 grams

## Specifications

Specifications are subject to change without notice

MODEL NO.	BEARING	RATED VOLTAGE	FREQUENCY	MAX. RATED CURRENT	MAX. INPUT POWER	SPEED	MAX. AIR FLOW		MAX. AIR PRESSURE		NOISE dB-A
		VAC	Hz	mA	W	R.P.M.	m <sup>3</sup> /min	CFM	mmH <sub>2</sub> O	IN H <sub>2</sub> O	
3E-115B-20	Ball	115	50/60	120/110	10/9	1750/2000	0.51/0.59	18/21	1.95/2.35	0.08/0.09	23/26
3E-115S-20	Sleeve										
3E-230B-20	Ball	230	50/60	75/70	12/11	1750/2000	0.51/0.59	18/21	1.95/2.35	0.08/0.09	23/26
3E-230S-20	Sleeve										
3E-115B-25	Ball	115	50/60	130/120	10/9	2150/2500	0.62/0.74	22/26	2.99/3.43	0.09/0.13	27/31
3E-115S-25	Sleeve										
3E-230B-25	Ball	230	50/60	85/75	13/12	2150/2500	0.62/0.74	22/26	2.99/3.43	0.09/0.13	27/31
3E-230S-25	Sleeve										
3E-115B-28	Ball	115	50/60	130/120	11/10	2400/2800	0.71/0.82	25/29	3.73/4.50	0.15/0.18	30/37
3E-115S-28	Sleeve										
3E-230B-28	Ball	230	50/60	85/75	13/12	2400/2800	0.71/0.82	25/29	3.73/4.50	0.15/0.18	30/37
3E-230S-28	Sleeve										
3E-115B	Ball	115	50/60	140/130	11/10	2700/3100	0.74/0.91	26/32	2.90/3.40	0.11/0.13	31/34
3E-115S	Sleeve										
3E-230B	Ball	230	50/60	85/75	13/12	2700/3100	0.74/0.91	26/32	2.90/3.40	0.11/0.13	31/34
3E-230S	Sleeve										
3E-DVB	Ball	230/115	50/60	80/150	13/13	2700/3000	0.79/0.91	26/32	2.90/3.40	0.11/0.13	33/38
3E-DVS	Sleeve										

## Dimensions (mm)

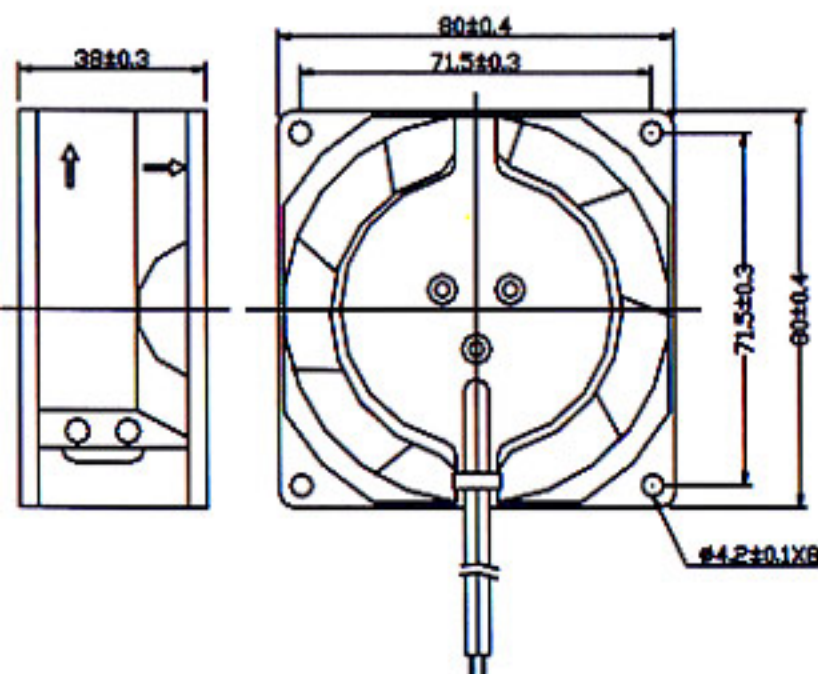

## Performance Curve

