

Customer :

No. SW063790A

ALPS ELECTRIC EUROPA GMBH

Date : 2006- 03- 20

Attention :

Your ref. No. :

Your Part No. : ALPS ELECTRIC EUROPE

SPECIFICATION

ALPS' ;

MODEL : SSSS210810

Spec. No. : SSSS2-S-801

Sample No. : F3026236M

RECEIPT STATUS

RECEIVED

By Date

Signature

Name

Title

ALPS[®]

ALPS ELECTRIC CO., LTD.

DSG' D

S. Takahashi

APP' D

T. Tomita

ENG. DEPT. DIVISION

Sales

Head Office

1-7, Yukigaya-otsuka-cho, Ota-ku, Tokyo. 145-8501 Japan

Phone. +81(3)3726-1211

Q1003#03A(EA)

DOCUMENT No. SSSS2-S-801	TITLE 製品仕様書	PRODUCT SPECIFICATIONS	PAGE 1/5
BACKGROUND			SSSS212 (S)

1. General 一般事項

- 1.1 Application 適用範囲 This specification is applied to low current circuit (Secondary circuit) slide switch used for electronic equipment. この仕様書は主として電子機器に用いる低電流回路用(2次側回路用)スライドスイッチに適用する。
- 1.2 Operating temperature range 使用温度範囲: -40 ~ 85°C
- 1.3 Storage temperature range 保存温度範囲: -40 ~ 85°C ▲
- 1.4 Test conditions 試験状態 Unless otherwise specified, the atmospheric conditions for making measurements and tests are as follows. 試験及び測定は特に規定がない限り以下の標準状態のもとで行う。
 Ambient temperature 温度: 5~35°C
 Relative humidity 相対湿度: 25~85%
 Air pressure 気圧: 86~106kPa(860~1060mbar) ▲
 Should any doubt arise in judgement, tests shall be conducted at the following conditions. ただし、判定に疑義を生じた場合は以下の基準状態で行う。
 Ambient temperature 温度: 20±2°C
 Relative humidity 相対湿度: 60~70%
 Air pressure 気圧: 86~106kPa(860~1060mbar) ▲

2. Appearance, construction and dimensions 外観、構造、寸法

- 2.1 Appearance 外観 Switch shall have good finishing, and no rust, crack or plating failures. 各部の仕上げは良好で、機能上有害な錆、傷、割れ、めっき不良及び剥離等があつてはならない。
- 2.2 Construction and dimensions 構造、寸法 Refer to individual product drawing. 個別製品図による。

3. Rating 定格

Maximum 最大定格	6 V DC 0.3 A (Resistive load)(抵抗負荷)
	12 V DC 0.1 A (Resistive load)(抵抗負荷)
	30 V DC 0.1 A (Resistive load)(抵抗負荷)
Minimum 最小定格	1 V DC 10 μA (Resistive load)(抵抗負荷)



4. Electrical specification 電気的性能

Items 項目	Test conditions 試験条件	Criteria 判定基準
4.1 Contact resistance 接触抵抗	Shall be measured at 1 kHz±200 Hz (20 mV MAX, 50 mA MAX) or 1 A, 5 V DC by voltage drop method. 1 kHz±200 Hz、電圧 20 mV 以下、電流 50 mA 以下による方法。 または DC 5V, 1A の電圧降下法で測定する。	70 mΩ MAX
4.2 Insulation resistance 絶縁抵抗	Test voltage: 500 V DC, measured after 1 min ± 5 s Applied position: Between all terminals Between terminals and ground(frame) DC 500 V の電圧を 1分±5秒間端子相互間、端子フレーム間に印加し、測定する。	100 MΩ MIN
4.3 Voltage proof 耐電圧	Test voltage: 500 V AC (50~60Hz, cut-off current 2 mA) Duration: 1 min Applied position: Between all terminals Between terminals and ground(frame) AC 500 V (50~60Hz、感度電流 2 mA) の電圧を 1分間端子相互間、端子フレーム間に印加する。	No dielectric breakdown shall occur. 絶縁破壊のないこと。
4.4 Changeover timing 切換タイミング		Refer to individual product drawing. 個別製品図による。

5. Mechanical specification 機械的性能

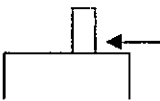
Items 項目	Test conditions 試験条件	Criteria 判定基準
5.1 Operating force 作動力	A static load shall be applied to the root of actuator in operating direction. 操作部の根元に作動方向へ静荷重を加えて測定する。 	Refer to individual product drawing. 個別製品図による。
5.2 Robustness of terminal 端子強度 ▲	A static load of 3 N(300gf) shall be applied to the tip of terminal in a desired direction for 1 min. The test shall be done once per terminal. 端子先端の一方へ 3 N(300gf) の静荷重を1分間加える。 ただし、回数は1端子当たり1回とする。	Shall be free from terminal looseness, damage and breakage of terminal holding portion. Terminals may be bent after test. Electrical performance requirement specified in item 4 shall be satisfied. 端子の脱落、破損及び端子保持部の破損のないこと。ただし、端子の曲がりは差し支えないものとする。また、試験後 4項の電気的性能を満足すること。

						1,2	▲ 6	得意先要求	Oct.24,2001	Y.T	Y.T	H.K		APPD.	CHKD.	DSGD.
							▲ 1	得意先要求	Feb.12,'98	H.O	IM	H.K				
5	▲ 1	得意先要求	July 30,2003	F.Y	F.Y	H.K		▲ 4	得意先要求	Oct.13,'97	H.O	IM	H.K	Oct.13,'97	Oct.13,'97	Oct.13,'97
5	▲ 1	No.211076による	Feb.14,2003	KJ	KJ	F.Y		INITIAL DESIGN	SSSS2123A	June07,'93	M.K	S.T	M.Y	H.	I.	H
PAGE	SYMB	BACKGROUND	DATE	APPD	CHKD	DSGD	PAGE	SYMB	BACKGROUND	DATE	APPD	CHKD	DSGD	Oba	Mikami	Kamada

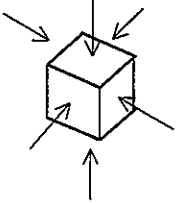
DOCUMENT No. SSSS2-S-801	TITLE PRODUCT SPECIFICATIONS 製品仕様書	PAGE 2/5
Items 項目	Test conditions 試験条件	Criteria 判定基準
5.3 Robustness of actuator 操作部強度	<p>A static load of 20 N (20 N) shall be applied in the operating direction of actuator for 15 s. 操作部の作動方向に 20 N (20 N) の静荷重を15秒間加える。</p> <p>A static load of 10 N (10 N) shall be applied in the pull direction of actuator for 15 s. 操作部の引張方向に 10 N (10 N) の静荷重を15秒間加える。</p> <p>A static load of 10 N (10 N) shall be applied in the perpendicular direction of operation at the tip of actuator for 15 s. 操作部の先端に作動方向と直角に 10 N (10 N) の静荷重を15秒間加える。</p>	Shall be free from pronounced wobble, deformation and mechanical abnormalities. 著しいガタ及び曲がりのないこと。 また、機械的に異常のないこと。
5.4 Wobble of actuator 操作部の振れ	Run-out(P-P) shall be measured by applying a static load of 1 N (1 N) in the perpendicular direction of operation at the tip of actuator. 操作部の先端に作動方向と直角に 1 N (1 N) の静荷重を加え、振れ幅(最大値)を測定する。	P-P: <u>1</u> mm MAX
5.5 Vibration 耐振性	<p>Switch shall be secured to a testing machine by a normal mounting device and method. Switch shall be measured after following test. スイッチを正規の取付用具、取付方法で試験機に固定し、下記条件で試験を行い、試験後測定する。</p> <p>(1)Vibration frequency range 振動数範囲: $10\sim 55\text{ Hz}$ (2)Total amplitude 全振幅: 1.5 mm (3)Sweep ratio 掃引の割合: $10\sim 55\sim 10\text{ Hz}$ Approx. 1 min 約1分 (4)Method of changing the sweep vibration frequency: Logarithmic or linear 掃引振動数の変化方法 対数又は直線近似 (5)Direction of vibration: Three perpendicular directions including actuator 振動の方向 操作部を含む垂直3方向 (6)Duration 振動時間: 2 h each (6 h in total) 各2時間(計6時間)</p>	<p>Contact resistance 接触抵抗 (Item 4.1): $70\text{ m}\Omega$ MAX Insulation resistance 絶縁抵抗 (Item 4.2): $100\text{ M}\Omega$ MIN Voltage proof 耐電圧 (Item 4.3): Apply 500 V AC for 1 min. No dielectric breakdown shall occur. 絶縁破壊のないこと。 Operating force 作動力 (Item 5.1): Within specified value. 規格値内とする。 Shall be free from mechanical abnormalities. 機械的に異常がないこと。</p>
5.6 Shock 耐衝撃性	<p>Switch shall be measured after following test. 下記条件で試験を行い、試験後測定する。</p> <p>(1)Mounting method 取付方法: Normal mounting method 正規の方法で取り付ける。 (2)Acceleration 加速度: 490 m/s^2 (500) Δ (3)Duration 作用時間: 11 ms (4)Test direction 試験方向: 6 directions 6面 (5)Number of shocks 試験回数: 3 times per direction (18 times in total) 各方向各3回(計18回)</p> 	<p>Contact resistance 接触抵抗 (Item 4.1): $70\text{ m}\Omega$ MAX Insulation resistance 絶縁抵抗 (Item 4.2): $100\text{ M}\Omega$ MIN Voltage proof 耐電圧 (Item 4.3): Apply 500 V AC for 1 min. No dielectric breakdown shall occur. 絶縁破壊のないこと。 Operating force 作動力 (Item 5.1): Within specified value. 規格値内とする。 Shall be free from mechanical abnormalities. 機械的に異常がないこと。</p>
5.7 Solderability はんだ付け性	<p>Switch shall be checked after following test. 下記条件で試験を行い、試験後確認する。</p> <p>(1)Solder はんだ: H63A (JIS Z 3282) (2)Flux フラックス: Rosin flux (JIS K 5902) having a nominal composition of 25% solids by mass of water white rosin in 2-propanol (JIS K 8839) solution. ロジン (JIS K 5902) の2-プロパノール (JIS K 8839) 溶液とし、濃度は質量比ロジン約25%とする。 (3)Soldering temperature はんだ温度: $230\pm 5\text{ }^\circ\text{C}$ Immersing time 浸漬時間: $3\pm 0.5\text{ s}$ Flux immersing time shall be $5\sim 10\text{ s}$ in normal room temperature. ただし、フラックス浸漬は常温で $5\sim 10\text{ s}$ とする。 (4)Immersion depth: Immersion depth shall be at copper plating portion for 浸漬深さ P.C.B. terminal after mounting. Thickness of P.C.B.: 1.6 mm Immersion depth shall be at wiring portion of lead wire for lead wire terminal. プリント基板用端子はプリント基板(t1.6)実装後、銅箔面まで浸漬。リード配線用端子は端子のリード線からげ部を浸漬。</p>	<p>More than <u>90</u> % of immersed part shall be covered with solder. If frame is made of tin-plate, cutting section shall not be applied. 浸漬した部分の <u>90</u> % 以上がはんだで覆われていること。 ただし、ぶりき拵の場合は、破断面は適用しない。</p>

DOCUMENT No. SSSS2-S-801	TITLE PRODUCT SPECIFICATIONS 製品仕様書	PAGE 3/5
-----------------------------	--	-------------

Items 項目	Test conditions 試験条件	Criteria 判定基準									
5.8 Resistance to soldering heat はんだ耐熱性	<p>Switch shall be measured after following test. 下記条件で試験を行い、試験後確認する。</p> <p>(1) Solder はんだ: H63A(JIS Z 3282), RH60(JIS Z 3283)</p> <p>(2) Flux フラックス: Rosin flux (JIS K 5902) having a nominal composition of (JIS K 8839) solution. ロジン(JIS K 5902)の2-プロパノール(JIS K 8839)溶液とし、濃度は質量比ロジン約25%とする。</p> <p>(3) Temperature and immersing time 温度と浸漬時間</p> <table border="1"> <thead> <tr> <th></th> <th>Temperature 温度(°C)</th> <th>Time 時間(s)</th> </tr> </thead> <tbody> <tr> <td>Dip soldering デイップはんだ</td> <td>260 ± 5</td> <td>5₋₁</td> </tr> <tr> <td>Manual soldering 手はんだ</td> <td>350 ± 10</td> <td>4 MAX</td> </tr> </tbody> </table> <p>(4) Immersion depth: Immersion depth shall be at copper plating portion for 浸漬深さ P.C.B. terminal after mounting. Thickness of P.C.B.(Single sided copper clad phenolic resin P.C.B.): 1.6 mm プリント基板用端子はプリント基板(片面銅張りフェノール樹脂積層板 t1.6)実装後、銅箔面まで浸漬。</p>		Temperature 温度(°C)	Time 時間(s)	Dip soldering デイップはんだ	260 ± 5	5 ₋₁	Manual soldering 手はんだ	350 ± 10	4 MAX	<p>No abnormalities shall be observed in appearance and operation. The electrical performance requirements specified in item 4 shall be satisfied. Soldering condition of each P.C.board thickness shall be according to paragraph 6 of precaution in use. 外觀に著しい変形のないこと。 また、動作に異常がなく、4項の電気的性能を満足すること。 各プリント基板、板厚ごとの半田付条件は、使用上の注意 6項による。</p>
	Temperature 温度(°C)	Time 時間(s)									
Dip soldering デイップはんだ	260 ± 5	5 ₋₁									
Manual soldering 手はんだ	350 ± 10	4 MAX									

7. Durability 耐久性能

Items 項目	Test conditions 試験条件	Criteria 判定基準								
6.1 Operating life without load 無負荷寿命	<p>Switch shall be operated 15,000 cycles at 15~20 cycles/min without load. 無負荷にて15,000サイクル(動作速度15~20サイクル/分)連続動作を行う。</p>	<p>Contact resistance 接触抵抗 (Item 4.1): 100 mΩ MAX</p> <p>Insulation resistance.Measured at DC 100V. 絶縁抵抗 DC 100V : 10 MΩ MIN</p> <p>Voltage proof 耐電圧 (Item 4.3): Apply 100 V AC for 1 min. No dielectric breakdown shall occur. 絶縁破壊のないこと。</p> <p>Operating force 作動力 (Item 5.1): Within $\pm 10\%$ of specified value. 規格値の $\pm 10\%$ 以内。</p> <p>No abnormalities shall be recognized in appearance and construction. 外觀、構造に異常がないこと。</p>								
6.2 Operating life with load 負荷寿命	<p>Switch shall be operated at 15~20 cycles/min with condition as following table. 下記表にて(動作速度15~20サイクル/分)連続動作を行う。</p> <table border="1"> <thead> <tr> <th>Load 負荷</th> <th>Cycles</th> </tr> </thead> <tbody> <tr> <td>6 V DC 0.3 A (Resistive load 抵抗負荷)</td> <td>15,000</td> </tr> <tr> <td>12 V DC 0.1 A (Resistive load 抵抗負荷)</td> <td>15,000</td> </tr> <tr> <td>30 V DC 0.1 A (Resistive load 抵抗負荷)</td> <td>10,000</td> </tr> </tbody> </table>	Load 負荷	Cycles	6 V DC 0.3 A (Resistive load 抵抗負荷)	15,000	12 V DC 0.1 A (Resistive load 抵抗負荷)	15,000	30 V DC 0.1 A (Resistive load 抵抗負荷)	10,000	<p>Contact resistance 接触抵抗 (Item 4.1): 130 mΩ MAX</p> <p>Insulation resistance.Measured at DC 100V. 絶縁抵抗 DC 100V : 10 MΩ MIN</p> <p>Voltage proof 耐電圧 (Item 4.3): Apply 100 V AC for 1 min. No dielectric breakdown shall occur. 絶縁破壊のないこと。</p> <p>Operating force 作動力 (Item 5.1): Within $\pm 10\%$ of specified value. 規格値の $\pm 10\%$ 以内。</p> <p>No abnormalities shall be recognized in appearance and construction. 外觀、構造に異常がないこと。</p>
Load 負荷	Cycles									
6 V DC 0.3 A (Resistive load 抵抗負荷)	15,000									
12 V DC 0.1 A (Resistive load 抵抗負荷)	15,000									
30 V DC 0.1 A (Resistive load 抵抗負荷)	10,000									

7.Environmental test 耐環境性

Items 項目	Test conditions 試験条件	Criteria 判定基準
7.1 Cold 耐寒性	<p>After testing at -40±2°C for 500h, the switch shall be allowed to stand under normal room temperature and humidity conditions for 1 h, and then measurement shall be made within 1 h. Water drops shall be removed. -40±2°Cにて500時間試験後、常温常湿中に1時間放置し1時間以内に測定する。ただし、水滴は取り除く。</p>	<p>Contact resistance 接触抵抗 (Item 4.1): 100 mΩ MAX</p> <p>Insulation resistance 絶縁抵抗 (Item 4.2): 10 MΩ MIN</p> <p>Voltage proof 耐電圧 (Item 4.3): Apply 500 V AC for 1 min. No dielectric breakdown shall occur. 絶縁破壊のないこと。</p> <p>Operating force 作動力 (Item 5.1): Within $\pm 10\%$ of specified value. 規格値の $\pm 10\%$ 以内。</p> <p>No abnormalities shall be recognized in appearance and construction. 外觀、構造に異常がないこと。</p>



DOCUMENT No. SSSS2-S-801		TITLE PRODUCT SPECIFICATIONS 製品仕様書		PAGE 4/5
Items 項目	Test conditions 試験条件	Criteria 判定基準		
7.2 Dry heat 耐熱性	<p>After testing at $85 \pm 2^\circ\text{C}$ for 500h, the switch shall be allowed to stand under normal room temperature and humidity conditions for 1 h, and then measurement shall be made within 1 h. $85 \pm 2^\circ\text{C}$にて500時間試験後、常温常湿中に1時間放置し1時間以内に測定する。</p> <p>△ After testing at $90 \pm 2^\circ\text{C}$ for 96 h, the switch shall be allowed to stand under normal room temperature and humidity conditions for 1 h, and then measurement shall be made within 1 h. $90 \pm 2^\circ\text{C}$にて96時間試験後、常温常湿中に1時間放置し1時間以内に測定する。</p>	<p>Contact resistance 接触抵抗 (Item 4.1): $100 \text{ m}\Omega$ MAX</p> <p>Insulation resistance 絶縁抵抗 (Item 4.2): $10 \text{ M}\Omega$ MIN</p> <p>Voltage proof 耐電圧 (Item 4.3): Apply 500 V AC for 1 min. No dielectric breakdown shall occur. 絶縁破壊のないこと。</p> <p>Operating force 作動力 (Item 5.1): Within $\begin{matrix} +10 \\ -30 \end{matrix}$ % of specified value. 規格値の $\begin{matrix} +10 \\ -30 \end{matrix}$ % 以内。</p> <p>No abnormalities shall be recognized in appearance and construction. 外観、構造に異常がないこと。</p>		
7.3 Damp heat 耐湿性	<p>After testing at $60 \pm 2^\circ\text{C}$ and $90 \sim 95\% \text{RH}$ for 500h, the switch shall be allowed to stand under normal room temperature and humidity conditions for 1 h, and then measurement shall be made within 1 h. Water drops shall be removed. $60 \pm 2^\circ\text{C}$、相対湿度 $90 \sim 95\%$にて500時間試験後、常温常湿中に1時間放置し1時間以内に測定する。ただし、水滴は取り除く。</p>	<p>Contact resistance 接触抵抗 (Item 4.1): $100 \text{ m}\Omega$ MAX</p> <p>Insulation resistance 絶縁抵抗 (Item 4.2): $10 \text{ M}\Omega$ MIN</p> <p>Voltage proof 耐電圧 (Item 4.3): Apply 100 V AC for 1 min. No dielectric breakdown shall occur. 絶縁破壊のないこと。</p> <p>Operating force 作動力 (Item 5.1): Within $\begin{matrix} +10 \\ -30 \end{matrix}$ % of specified value. 規格値の $\begin{matrix} +10 \\ -30 \end{matrix}$ % 以内。</p> <p>No abnormalities shall be recognized in appearance and construction. 外観、構造に異常がないこと。</p>		
7.4 Salt mist 塩水噴霧	<p>Switch shall be checked after following test. 下記条件で試験を行い、試験後確認する。 (1) Temperature 温度: $35 \pm 2^\circ\text{C}$ (2) Salt solution 塩水濃度: $5 \pm 1\%$ (Solids by mass) (質量比) (3) Duration 試験時間: $24 \pm 1 \text{ h}$ After the test, salt deposit shall be removed in running water. 試験後試料に付着した塩堆積物を流水で落とす。</p>	<p>No remarkable corrosion shall be recognized in metal part. 機能上有害な著しいさびがないこと。</p>		
7.5 Change of temperature 温度サイクル	<p>After 5 cycles of following conditions, the switch shall be allowed to stand under normal room temperature and humidity conditions for 1 h, and measurement shall be made within 1 h after that. Water drops shall be removed. 下記条件で5サイクル試験後、常温常湿中に1時間放置し1時間以内に測定する。ただし、水滴は取り除く。</p>	<p>Contact resistance 接触抵抗 (Item 4.1): $100 \text{ m}\Omega$ MAX</p> <p>Insulation resistance 絶縁抵抗 (Item 4.2): $10 \text{ M}\Omega$ MIN</p> <p>Voltage proof 耐電圧 (Item 4.3): Apply 100 V AC for 1 min. No dielectric breakdown shall occur. 絶縁破壊のないこと。</p> <p>Operating force 作動力 (Item 5.1): Within $\begin{matrix} +10 \\ -30 \end{matrix}$ % of specified value. 規格値の $\begin{matrix} +10 \\ -30 \end{matrix}$ % 以内。</p> <p>No abnormalities shall be recognized in appearance and construction. 外観、構造に異常がないこと。</p>		
7.6 Damp heat with load (Resistance to silver migration) 耐湿負荷 (耐銀マイグレーション特性)	<p>DC voltage 1.5 times as much as rated voltage shall be applied continuously between adjacent terminals at $60 \pm 2^\circ\text{C}$ and $90 \sim 95\% \text{RH}$. After 500 h testing, switch shall be allowed to stand under normal room temperature and humidity conditions for 1 h, and measurement shall be made within 1 h after that. Water drops shall be removed. $60 \pm 2^\circ\text{C}$、相対湿度 $90 \sim 95\%$にて隣接端子間に定格電圧の1.5倍の直流電圧を連続印加し、500時間試験後、常温常湿中に1時間放置し1時間以内に測定する。ただし、水滴は取り除く。</p>	<p>Insulation resistance 絶縁抵抗 (50V DC): $10 \text{ M}\Omega$ MIN</p> <p>Voltage proof 耐電圧: Apply 100 V AC for 1 min. No dielectric breakdown shall occur. AC 100 V、1分間印加。 絶縁破壊のないこと。</p>		

DOCUMENT No. SSSS2-S-801		TITLE PRODUCT SPECIFICATIONS 製品仕様書		PAGE 5/5																								
Items 項目	Test conditions 試験条件	Criteria 判定基準																										
7.7 △ Resistance to sulfuration 耐硫化水素ガス	After following testing, the switch shall be allowed to stand under normal room temperature and humidity conditions for 1 h, and measurement shall be made after that. 下記条件で試験後、常温常湿中に1時間放置し測定する。 Temperature 温度: 40±2 °C Humidity 湿度: 75±5 %RH Density 濃度: H ₂ S gas 1±0.2 ppm Duration 試験時間: 240 h	Contact resistance 接触抵抗 (Item 4.1): 500 mΩ MAX Insulation resistance 絶縁抵抗 (Item 4.2): 10 MΩ MIN Voltage proof 耐電圧 (Item 4.3): Apply 250 V AC for 1 min. No dielectric breakdown shall occur. 絶縁破壊のないこと。 Operating force 作動力 (Item 5.1): Within $\begin{matrix} +10 \\ -30 \end{matrix}$ % of specified value. 規格値の $\begin{matrix} +10 \\ -30 \end{matrix}$ % 以内。 No abnormalities shall be recognized in appearance and construction. 外観、構造に異常がないこと。																										
【Precaution in use】 ご使用上の注意																												
<p>1. Note that if the load is applied to the terminals during soldering they might suffer deformation and defects in electrical performance. 端子をはんだ付けされる場合、端子に荷重が加わりますと条件によりガタ、変形及び電気的特性劣化のおそれがありますのでご注意ください。</p> <p>2. Use of water-soluble soldering flux shall be avoided because it may cause corrosion of the switch. はんだ付けの際、水溶性フラックスはスイッチを腐食させるおそれがありますのでご使用はお避け下さい。</p> <p>3. Excessive operating force over specified value shall be avoided to the actuator because it is small and weak. 操作部は小さいため強度が弱くなっておりますので、操作部に規格値以上の力が加わらないようにご配慮下さい。</p> <p>↓ Designing printed pattern and parts layout shall be considered because the characteristics may change due to warp of P.C.B. 基板のソリによって特性が変化する場合がありますので、パターン設計・レイアウトについては十分考慮願います。</p> <p>5. When soldering, slide should be at the P position in product drawing. はんだ付けの際、スライドのつまみを製品図と同位置に移動させてはんだ付け下さい。</p> <p>6. For series SSSS212, operation may be heavy if the switch is used with a case fixed or 2 pos in a line. When 2 pcs of switches are used in a line, please detach them 1 mm at least. SSSS212は、セットに取り付ける際、ケースを固定、もしくは2個重ねて(並べて)使用しますと、動作が渋く(重く)なりますのでご注意ください。</p> <p>7. For series SSSS212, knob horizontal type, soldering flux might be flowed in the switch in case of auto-dip soldering. Therefore manual soldering shall be available. SSSS212ツマミ横だしタイプは、スイッチ構造上AUTO-DIPされますと、スイッチ内部にフラックスが流入する場合があります。ご使用の際は手半田で行う様ご配慮下さい。</p> <p>8. Unstable contact may occur if the switch is used lower than DC 1V or 10 μA. Please consult us for special applications. 電圧DC1V以下または電流10 μA以下で使用しますと、接触不安定となることがあります。このような用途に使用される場合は別途ご相談下さい。</p> <p>9. This switch is designed and manufactured to be used for general electronic equipment such as audio-visual equipment, home electronics, information and communication related equipment. If you intend to use the switch for sophisticated equipment requiring more safety and reliability, such as life support, space and aviation, disaster prevention or security related equipment, please feel free to contact us about suitability. 本製品はオーディオ機器、映像機器、家電機器、情報機器、通信機器などの一般電子機器用に設計・製造したものです。生命維持装置、宇宙・航空機器、防災・防犯機器などの高度の安全性や信頼性が求められる用途に使用される場合は、貴社にて適合性の確認を頂くか、当社へご相談下さい。</p> <p>10. In case of storing this switch for a long period (longer than six months after delivery), it must be sealed in a plastic bag and stored in a cool and dark place in order to prevent the solderability of the terminal surface from deteriorating due to film to be formed on it. 長期保管の場合(納入後6ヶ月程度以上)は、端子表面の皮膜形成によるはんだ付け性の劣化等を防ぐため、製品をビニル袋等で密封し、直射日光の当たらない冷暗所に保管して下さい。</p> <p>11. The soldering condition of series SSSS shall be as follows. The deformation or defects in electrical performance might be occurred if time or temperature exceed this specification. SSSS2の半田条件は、下記の仕様をお願いします。時間又は温度が当規格よりオーバーされますと変形及び電気的特性劣化のおそれがありますのでご注意ください。</p> <p>△ 12. This switch is lower detent feeling shall be confirm that after operating life test. 動作寿命試験後に節度感が少なくなる場合がありますので事前評価での確認をお願いします。</p> <p>△ Dip soldering ティップの場合 ・Temperature 温度 : 260±5°C ・Time 時間 : 5$\begin{matrix} 0 \\ -1 \end{matrix}$ S △ Pre-heating condition プリヒート条件 Temperature (At the upside surface of P.C.B.) 温度(プリント基板の上面) : 120°C MAX Time 時間 : 60 S</p>																												
<table border="1"> <thead> <tr> <th>Temperature of soldering iron tip こて先温度(°C)</th> <th>260±10</th> <th>300±10</th> <th>350±10</th> </tr> </thead> <tbody> <tr> <td>Thickness of P.C.board プリント基板厚(mm)</td> <td></td> <td></td> <td></td> </tr> <tr> <td>0.8</td> <td>5</td> <td>5</td> <td>3</td> </tr> <tr> <td>1.0</td> <td>5</td> <td>5</td> <td>3</td> </tr> <tr> <td>1.2</td> <td>5</td> <td>5</td> <td>4</td> </tr> <tr> <td>1.6</td> <td>5</td> <td>5</td> <td>4</td> </tr> </tbody> </table>					Temperature of soldering iron tip こて先温度(°C)	260±10	300±10	350±10	Thickness of P.C.board プリント基板厚(mm)				0.8	5	5	3	1.0	5	5	3	1.2	5	5	4	1.6	5	5	4
Temperature of soldering iron tip こて先温度(°C)	260±10	300±10	350±10																									
Thickness of P.C.board プリント基板厚(mm)																												
0.8	5	5	3																									
1.0	5	5	3																									
1.2	5	5	4																									
1.6	5	5	4																									
* Abnormal pressure shall not be applied to the terminal. 但し端子に異常加圧のないこと。																												
Notes 注) (1) P.C.board shall be single sided copper clad P.W.B. プリント基板については、片面銅張フェノール樹脂積層板とする。 (2) This test shall be performed up to twice. After first test, temperature shall be back to normal. 本試験は2回までとし、1回目試験後は一旦常温に戻すこととする。																												

背
BACK GROUND
SI 単位化

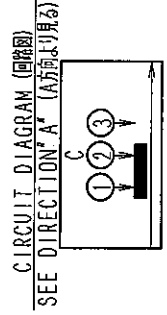
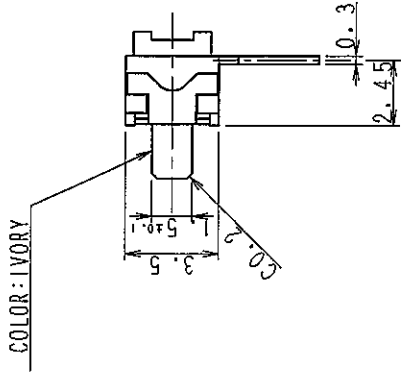
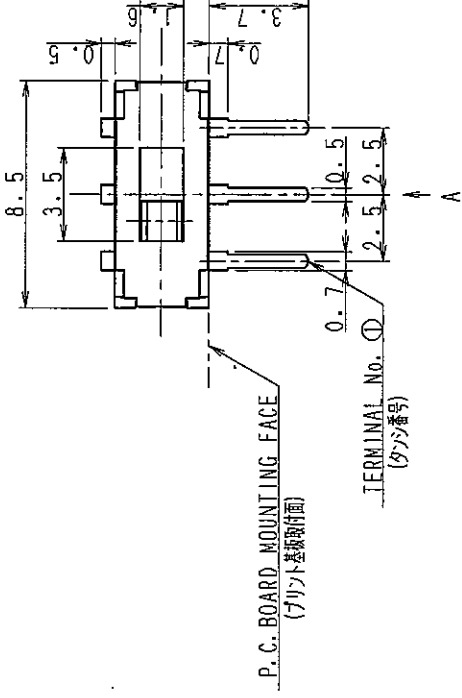
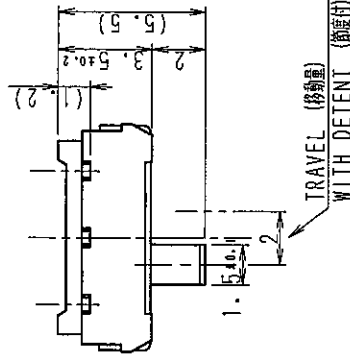

2. OPERATING FORCE: 2 ± 1.5 N ± 20% ± 1.5 mm (移動力)
 (MEASURE AT THE BOTTOM OF KNOB)
 (取ツマミ底部にて測定する)
1. CHANGE OVER TIMING OF CONTACTS: NONSHORTING
 (接点の切換タイミング: ノンショートング)

TOLERANCES UNLESS OTHERWISE SPEC.		ALPS ELECTRIC CO., LTD.	
BASIC DIMENSIONS	TOLERANCES	UNIT	SCALE
UP TO 4	±0.2	mm	%
OVER 4 UP TO 16	±0.3	mm	
OVER 16 UP TO 83	±0.4	mm	
ABOVE 83 TO 250	±0.5	mm	
ABOVE 250	±0.7	mm	
ANGULAR DIMENSIONS	±3°		

MODEL NO. (機種)	SSSS210810
TITLE	PRODUCT DRAWING (製品図)
DOCUMENT NO.	SSSS210810.AE11.003
APPD.	Yoshizawa Kise
CHKD.	Kishi
DSGD.	M.
DATE	2 Sep. 5 '02
ZONE	K1
APPD. CHKD. DSGD.	M. G. H.