

DATE	DRAWN	CHKD	SCALE	DRAWING NUMBER
14 MAR 94	BMC		1:1	J-19-14

REV.	DATE	BY-CHKD	REVISIONS	ITEM	COMPONENT	PART No.	MATERIAL	FINISH
A	11 APR 94	BMC	INCREASED DOOR THICKNESS	ASSEMBLY		19-14-10		
B	05 MAY 94	BMC	PRN: 19-92					
C	04 JAN 95	JGK	PRN: 19-113		HANDLE		DIE CAST ZINC	SEE NOTE "B"
D	05 MAY 95	MMM	PRN: 19-122		SHAFT		BRASS	SEE NOTE "C"
E	09 OCT 96	SWD	PRN: S-93-23		PIN		303 STAINLESS STEEL	SEE NOTE "A"
F	02 JAN 2002	DLH	PRN: P2002-0764		BUSHING		SBR RUBBER	BLACK

INSTALLATION INSTRUCTIONS:

- PREPARE A SHAPED HOLE IN DOOR OR OUTER PANEL AND A ROUND HOLE IN THE FRAME.
- WITH HANDLE IN OPEN POSITION INSERT SHAFT THROUGH HOLE IN DOOR, THEN PASS BUSHING OVER SHAFT AND SECURE WITH NYLON NUT.
- ADJUST NYLON NUT TO PROVIDE A SATISFACTORY HOLD IN, OR BEHIND FRAME HOLE WITH MODERATE LOCKING FORCE.

NOTE A: BLACK OXIDE COATING.
 NOTE B: BLACK POWDER COATING.
 NOTE C: ZINC PLATE, BLACK CHROMATE

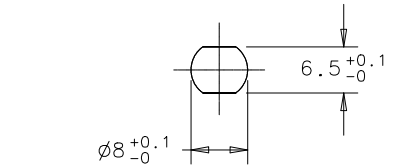

PANEL PREPARATION FOR DOOR OR OUTER PANEL.

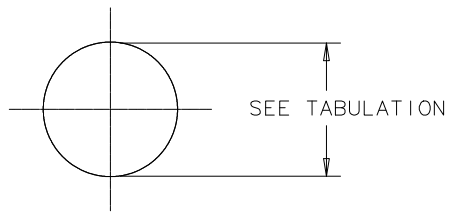

PANEL PREPARATION FOR FRAME

RECOMMENDED FRAME HOLE DIAMETERS

FRAME THICKNESS	HOLE DIAMETER
1.2 TO 3.2	19 ^{+0.5} / _{-0.0}
3.2 TO 4.8	19.5 ^{+0.5} / _{-0.0}
4.8 TO 6.4	20 ^{+0.5} / _{-0.0}
6.4 AND UP	20.5 ^{+0.5} / _{-0.0}

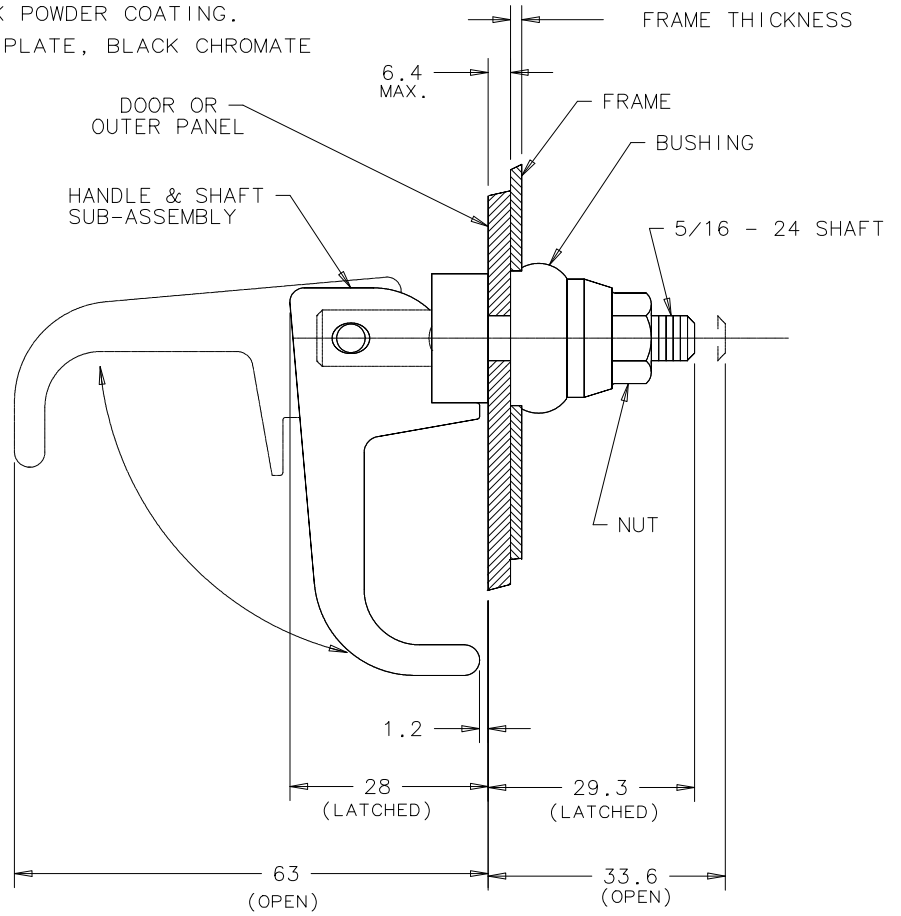
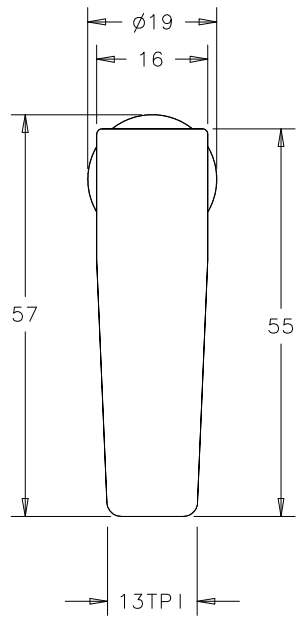

FORMAT A 3/88

PROPRIETARY ITEM - EXCEPT FOR USES EXPRESSLY GRANTED IN WRITING INFORMATION DISCLOSED HEREON IS CONFIDENTIAL AND ALL RIGHTS PATENT AND OTHERWISE ARE RESERVED BY SOUTHCO, INC.

SHIPPED UNASSEMBLED, ONE UNIT PER BAG.

DRAWING NUMBER
J-19-14