

THIS DRAWING IS UNPUBLISHED.
VERTRAULICHE UNVERÖFFENTLICHTE ZEICHNUNG

RELEASED FOR PUBLICATION
FREI FUER VERÖFFENTLICHUNG

MATED WITH:
PASSEND ZU:

LOC
AI

DIST
-

REVISIONS
ÄNDERUNGEN

BY AMP INCORPORATED.

ALL RIGHTS RESERVED.
ALLE RECHTE VORBEHALTEN

HG-Q8

PROJEKT NR.:
800-16

P

LTR

A2

DESCRIPTION
DIMENSION ADDED ECR-05-017240

DATE
05.10.04

DWN
SM

APVD
St

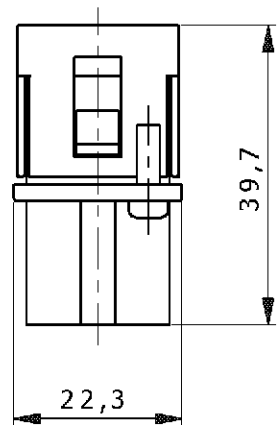
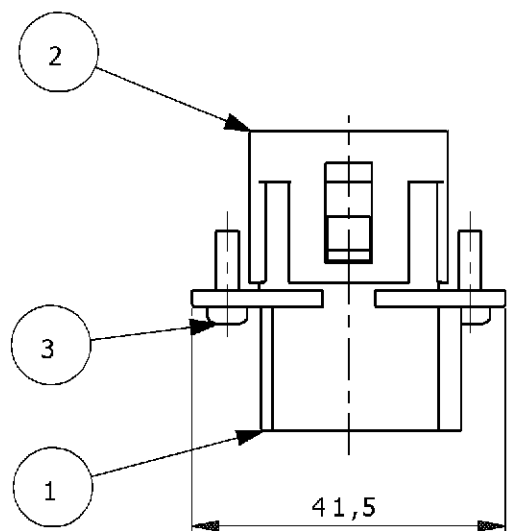

Contact arrangement
view from termination side

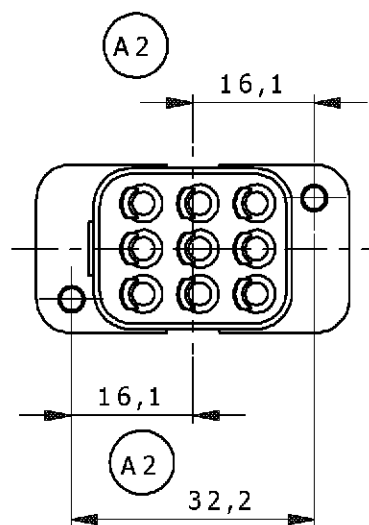
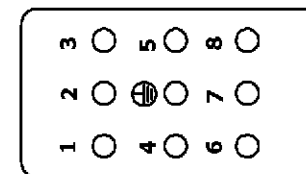

0-1 as shown

QTY.	PART-NO.	DESCRIPTION	MATERIAL	SURFACE	NOTE	ITEM
2	0-1110916-2	Screw for plastics / Schraube für Kunststoff	Steel / Stahl	Zinc plated	EJOT DELTA PT 3x10-Z	3
1	0-1245272-1	Cover / Deckel	Crastin	Light Grey		2
1	0-1245273-1	Female Insert / Buchseneinsatz	Lexan	Light Grey		1

PARTS LIST

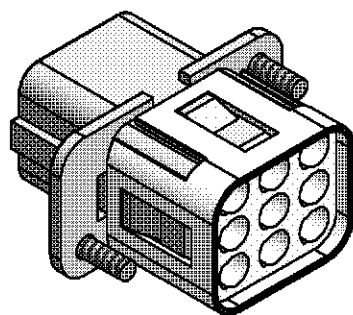

THIS DRAWING IS A CONTROLLED DOCUMENT FOR AMP INCORPORATED. IT IS SUBJECT TO CHANGE AND THE CONTROLLING ENGINEERING ORGANIZATION SHOULD BE CONTACTED FOR THE LATEST REVISION. DIESES ZEICHNUNGSDOKUMENT WIRD DURCH AMP INCORPORATED KONTROLLIERT. ÄNDERUNGEN, DIE DEM TECHNISCHEN FORTSCHRITT DIENEN, SIND VORBEHALTEN. DEN JEWELIS LETZTGÜLTIGEN ÄNDERUNGSSTAND ERFAHREN SIE AUF ANFRAGE.		DWN M. Schweiger 06.10.2004 CHK M. Schweiger 05.10.2004 APVD T. Schnurpfeil 05.10.2004		Tyco / Electronics AMP GmbH D - 53819 Neunkirchen	
DIMENSIONS: DIMENSIONEN: mm		TOLERANCES UNLESS OTHERWISE SPECIFIED: ALLGEMEIN TOLERANZEN n. ISO 8015 n. ISO 2768 - mH -E n. DIN 16901 - 140		NAME Female insert Buchseneinsatz HG-Q8.Bu.C	
		PRODUCT SPEC 108-74XXX APPLICATION SPEC 114-74XXX		SIZE A3 CAGE CODE 00779 DRAWING NO ZEICHNUNGS-NR. 1103071	
MATERIAL		FINISH / OBERFLÄCHE / FARBE		RESTRICTED TO NUR FUER	
WEIGHT GEWICHT 0,015 KG				SCALE MASSSTAB 1:1	
CUSTOMER DRAWING /KUNDENZEICHNUNG				SHEET BLATT 1 OF VON 1 REV A2	