

# Distinctive Characteristics

Sealing at front and back panel meets IP67 and IP60 of IEC60529 Standards. (Contact factory for further details regarding operating environment.)

Single unit construction of bushing and case gives added protection from environmental elements.

Antijamming design protects contacts from damage due to excessive downward force on the toggle.

Specially designed contact mechanism for breaking light contact welds.

Minimal contact bounce achieved with designed interlocked switching mechanism.

Heat resistant resin used for outer housing meets UL94V-0 flammability standard and provides high arc and tracking resistance.

Epoxy sealed base covered by outer case doubles protection from dust and water (not operable under water or oil).

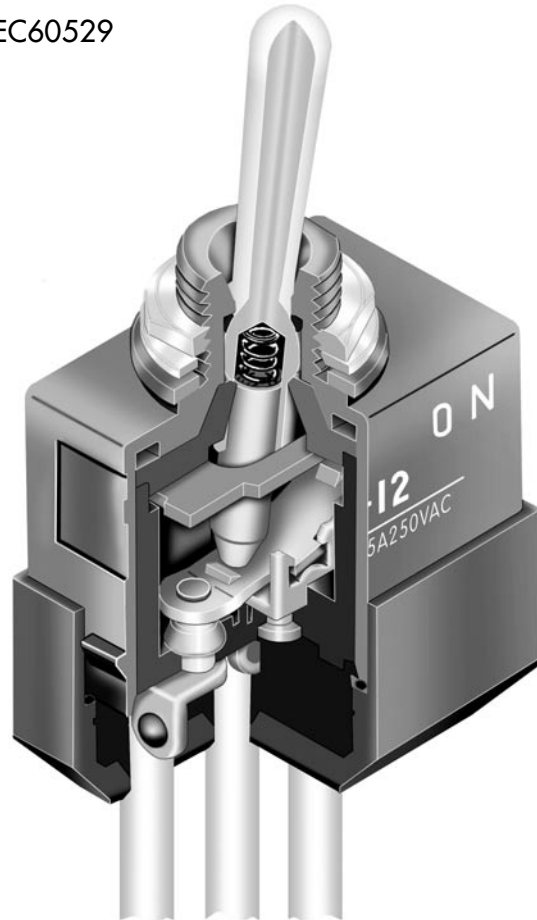

Actual Size

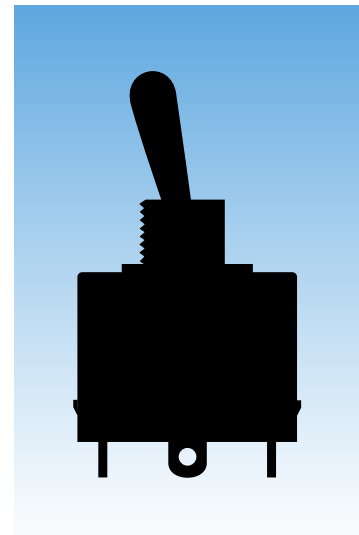

## General Specifications

### Electrical Capacity (Resistive Load)

**Power Level:** 10A @ 125V AC or 6A @ 250V AC or 10A @ 30V DC

### Other Ratings

**Contact Resistance:** 10 milliohms maximum for solder lug & screw terminal models;  
30 milliohms maximum for wire lead terminal models

**Insulation Resistance:** 200 megohms minimum @ 500V DC

**Dielectric Strength:** 1,500V AC minimum for 1 minute minimum

**Mechanical Life:** 50,000 operations minimum for On-None-Off, On-None-On, & On-Off-On models  
30,000 operations minimum for all other models

**Electrical Life:** 15,000 operations minimum

**Angle of Throw:** 24°

### Materials & Finishes

**Toggle:** Brass with chrome plating

**Bushing & Outer Case:** Fiberglass reinforced polyamide (UL94V-0)

**Inner Case:** Melamine

**Inner Sealing Ring:** Nitrile butadiene rubber for On-None-Off, On-None-On, & On-Off-On models;  
silicone rubber for all other models

**Outer Sealing Ring:** Natural rubber

**Movable Contactor:** Copper with silver plating

**Movable Contacts:** Silver alloy plus copper with silver plating

**Stationary Contacts:** Silver alloy plus copper with silver plating

**Terminals:** Copper with tin plating for solder lug & wire lead; brass with silver plating for screw lug

**Wire Lead Covers:** Heat resistant polyvinyl chloride (Leads are AWG 16)

### Environmental Data

**Operating Temp Range:** -30°C through +70°C (-22°F through +158°F)

**Humidity:** 90 ~ 95% humidity for 96 hours @ 40°C (104°F)

**Vibration:** 10 ~ 55Hz with peak-to-peak amplitude of 1.5mm traversing the frequency range  
& returning in 1 minute; 3 right angled directions for 2 hours

**Shock:** 50G (490m/s<sup>2</sup>) acceleration (tested in 6 right angled directions, with 5 shocks in each direction)

**Front Panel Seal:** IP67 of IEC60529, dust tight & water protected during temporary immersion for all models;  
optional toggle boot AT401 for additional protection (details at end of WT section)

**Behind Panel Seal:** IP60 of IEC60529, dust tight but not water protected  
for solder lug & screw terminal models  
IP67 of IEC60529, dust tight & water protected during temporary immersion  
for wire lead models

### Installation

**Soldering Time & Temp:** Manual Soldering: See Profile A in Supplement section.

**Mounting Torque:** 1.47Nm (13 lb•in)

### Standards & Certifications

**Flammability Standards:** UL94V-0 outer case

**Wiring Material Standards:** UL AWM 1015 Recognized at Flammability VW-1;  
Temperature Range -20°C ~ +105°C; Maximum Load 600V; AWG 16.  
CSA TEW 105 Certified at Temperature Range -20°C ~ +105°C;  
Maximum Load 600V

## TYPICAL SWITCH ORDERING EXAMPLE

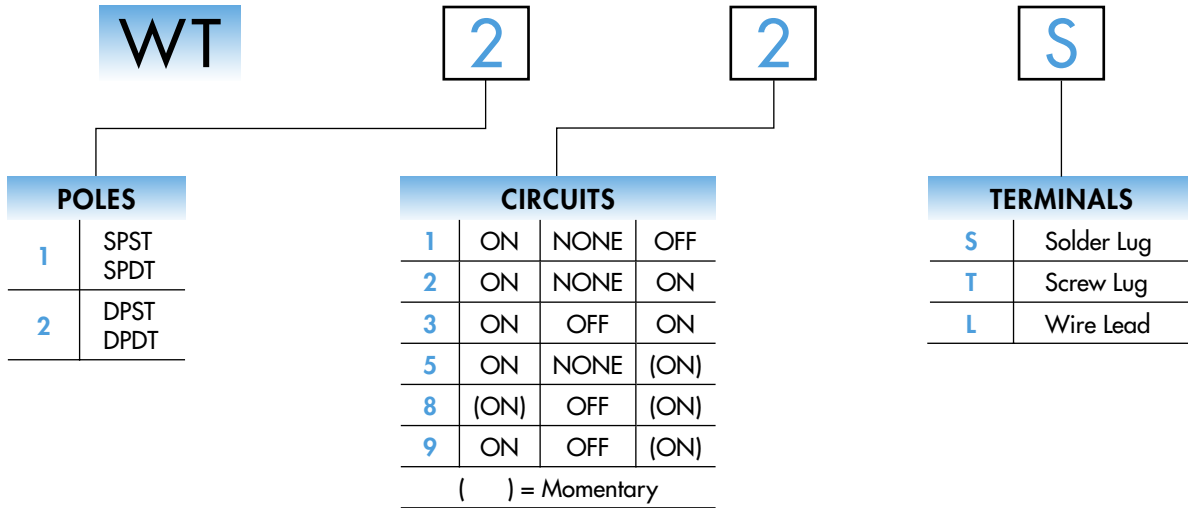

### DESCRIPTION FOR TYPICAL ORDERING EXAMPLE

#### WT22S

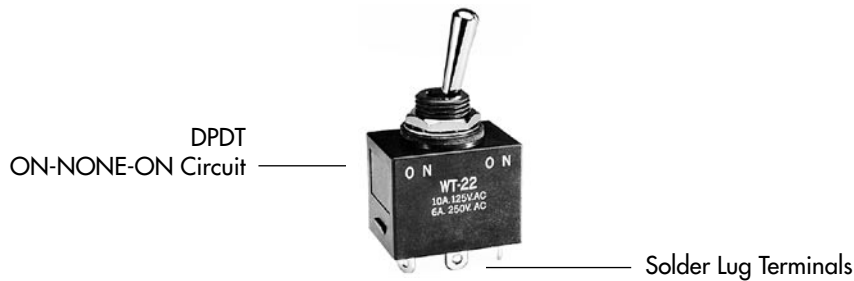

## POLES & CIRCUITS

Pole	Model	Toggle Position ( ) = Momentary			Connected Terminals			Throw & Schematics
		Down <small>Flat</small>	Center	Up	Down <small>Flat</small>	Center	Up	
SP	WT11	ON	NONE	OFF	1a-1b	OPEN	OPEN	Note: Terminal numbers are not actually on wire lead models. 
SP	WT12 WT13 WT15 WT18 WT19	ON ON ON (ON) ON	NONE OFF NONE OFF OFF	ON ON (ON) (ON) (ON)	1-1b	OPEN	1-1a	
DP	WT21	ON	NONE	OFF	1a-1b 2a-2b	OPEN	OPEN	
DP	WT22 WT23 WT25 WT28 WT29	ON ON ON (ON) ON	NONE OFF NONE OFF OFF	ON ON (ON) (ON) (ON)	1-1b 2-2b	OPEN	1-1a 2-2a	

## TYPICAL SWITCH DIMENSIONS

### Single Throw • Solder Lug

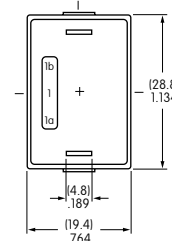
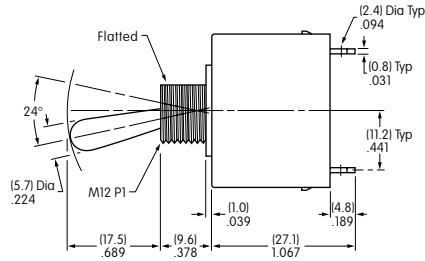
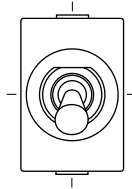

Single Pole

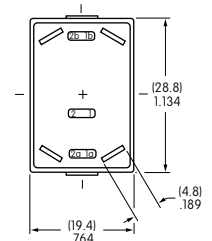

Double Pole

WT11S

### Double Throw • Solder Lug

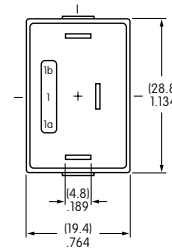
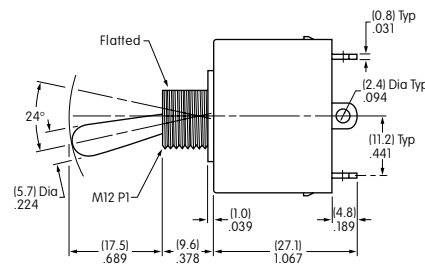
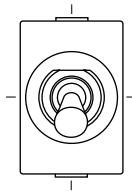

Single Pole

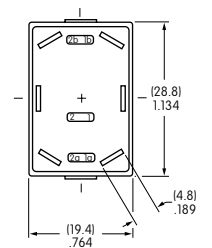

Double Pole

WT22S

### Single Throw • Screw Lug

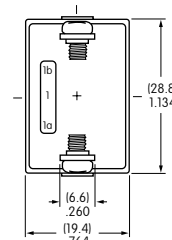
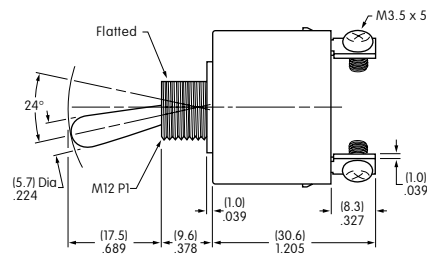
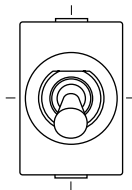

Single Pole

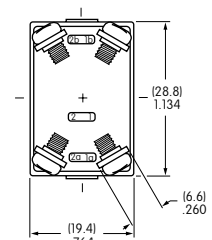

Double Pole

WT21T

## TYPICAL SWITCH DIMENSIONS

### Double Throw • Screw Lug



WT22T

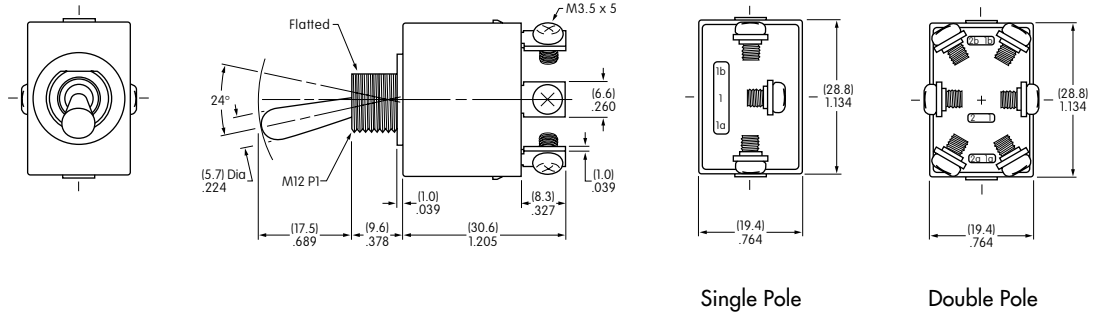

### Single & Double Pole • Wire Lead



WT22L

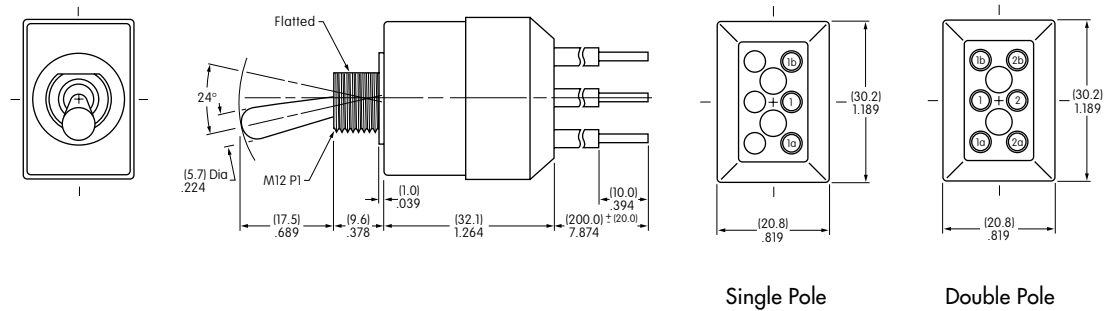

## STANDARD WIRE COLOR SCHEME

Wire leads are covered with heat resistant vinyl in accordance to UL 1015 and CSA TEW 105 Standards for Appliance Wiring Material (AWM).

	Terminal Numbers & Wire Colors					
	1a	1	1b	2a	2	2b
<b>WT11</b>	Black		White			
<b>WT12-19</b>	White	Black	Red			
<b>WT21</b>	Black		White	Blue		Yellow
<b>WT22-29</b>	White	Black	Red	Yellow	Blue	Green

## PANEL CUTOUT & THICKNESS

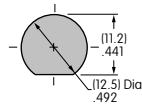

Maximum Effective Panel Thickness  
with Standard Hardware: .157" (4.0mm)

Maximum Effective Panel Thickness  
with optional Boot Assembly: .063" (1.6mm)

## STANDARD HARDWARE

**AT503M Hex Face Nut**  
Brass with Chrome Plating

1 supplied with each switch

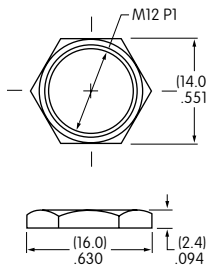

**AT508 Internal Tooth Lockwasher**  
Steel with Zinc/Chromate

1 supplied with each switch

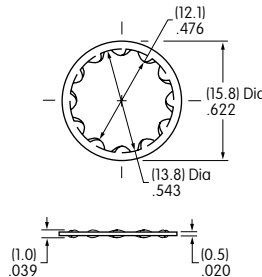

**AT401P O-ring**  
Natural Rubber

1 supplied with each switch

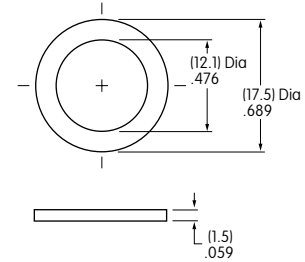

## OPTIONAL ACCESSORIES

### Boot Assemblies for High Particulate Contamination Applications

**AT401A for Oil Resistance**

Boot Material:  
Black nitrile butadiene rubber

Hex Nut Material & Finish:  
Nickel plated brass

O-ring Material: Natural rubber

**AT401H for Dust & Ozone Resistance**

Boot Material:  
Gray ethylene propylene rubber

Hex Nut Material & Finish:  
Nickel plated brass

O-ring Material: Natural rubber

**AT401S for retention of flexibility, resilience, & tensile strength over wide temperature range**

Boot Material:  
Black silicone rubber

Hex Nut Material & Finish:  
Nickel plated brass

O-ring Material: Natural rubber

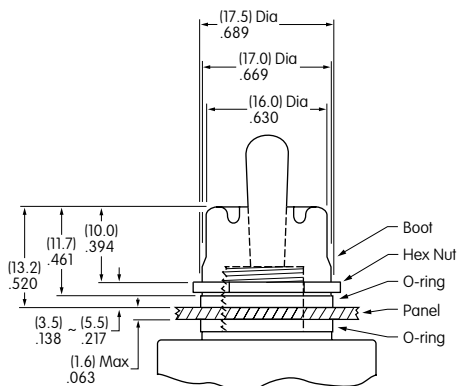

Note: When using boot assembly AT401A/H/S, also use o-ring AT401P from the standard hardware supplied. Hex face nut AT503M and lockwasher AT508 are not used with the boot assembly.

