

THIS DRAWING IS UNPUBLISHED. RELEASED FOR PUBLICATION OCT ,2003.
 © COPYRIGHT 2003 BY TYCO ELECTRONICS CORPORATION. ALL RIGHTS RESERVED.

LOC	DIST	REVISIONS			
P	LTR	DESCRIPTION	DATE	DWN	APVD
E	B	B	EBDO-0068-04	27JAN2004	JMS FWK

- NOTES:
- FOR LOCAL DATA REFER TO YOUR LOCAL TYCO ELECTRONICS SALES OFFICE.
 - ALL DIMENSIONS ARE NOMINAL FOR REFERENCE ONLY UNLESS OTHERWISE STATED.
 - MATERIAL :
 HOUSING : THERMOPLASTIC, UL94V-0
 BLACK COLOR
 CONTACTS : BRASS
 SHELL : STEEL
 BOARDLOCK : BRASS
 SCREW : BRASS
 - FINISH :
 CONTACT : 0.38µm MIN.GOLD PLATED ON CONTACT AREA
 2.54µm MIN. TIN PLATED ON SOLDER TAILS
 1.27µm MIN. NICKEL UNDERPLATED OVERALL
 SHELL : 1.52µm MIN. TIN PLATED
 BOARD LOCK : 1.52µm MIN. TIN PLATED
 SCREW : 1.27µm MIN. NICKEL PLATED.
 - CHARACTERISTICS
 CURRENT RATING : 5A
 INSULATION RESISTANCE : 1000MOHMS MIN, 500VDC FOR 2MINS.
 TEMPERATURE RATING : -55DEGC ~ +105DEGC
 VOLTAGE RATING : 250VDC

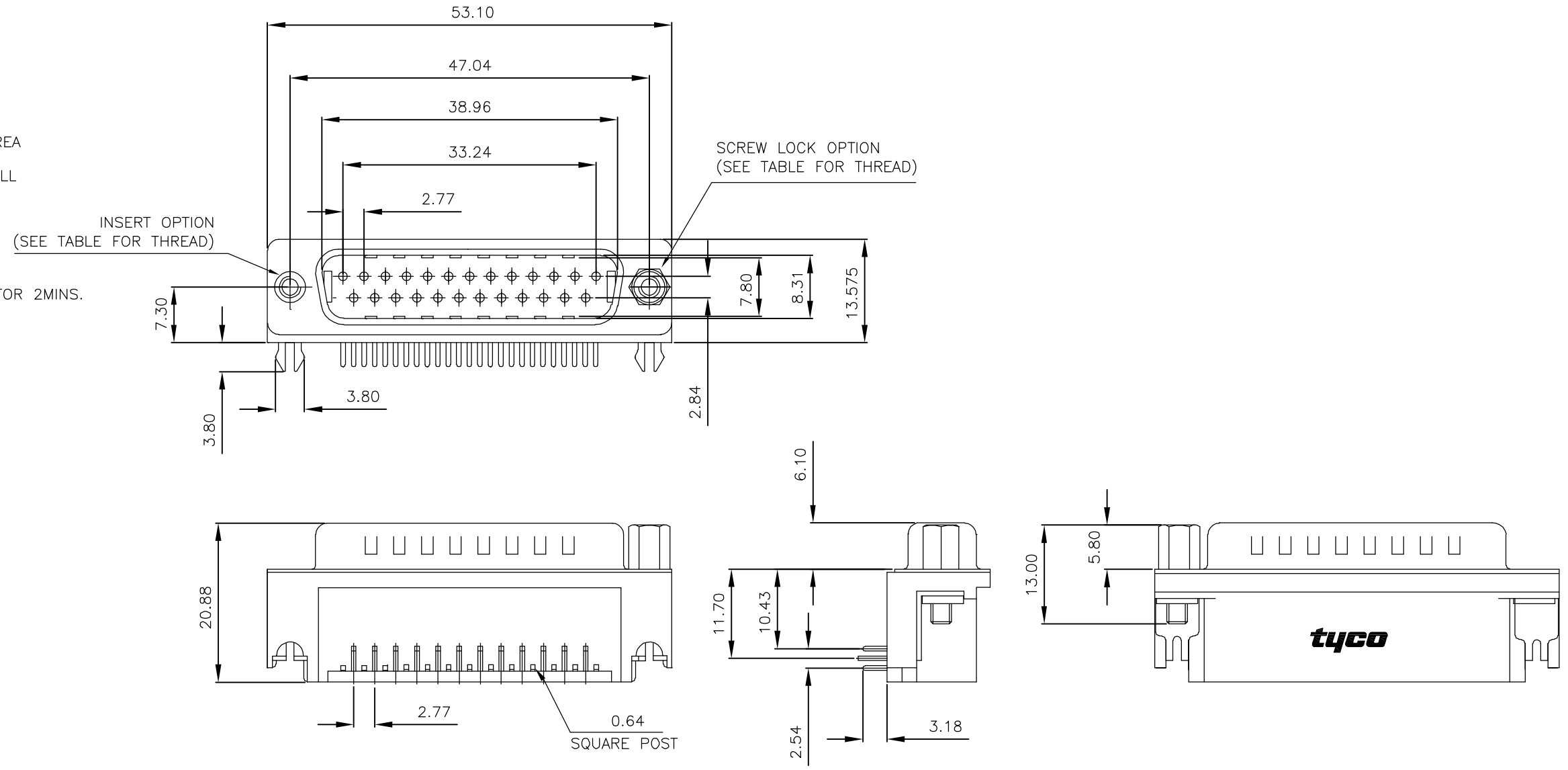

P.C.B. LAYOUT

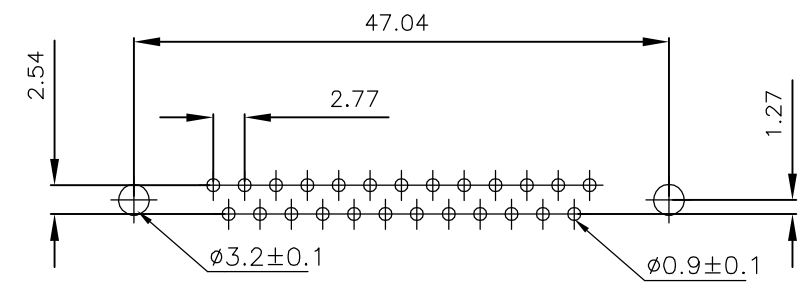

25 WAY D PLUG WITH BOARD LOCKS & 2 x M3 SCREW LOCKS, 0.38µm GOLD, RIGHT ANGLE	4-1634582-2
25 WAY D PLUG WITH BOARD LOCKS & 2 x 4-40 SCREW LOCKS, 0.38µm GOLD, RIGHT ANGLE	3-1634582-2
25 WAY D PLUG WITH BOARD LOCKS & 2 x M3 INSERTS, 0.38µm GOLD, RIGHT ANGLE	2-1634582-2
25 WAY D PLUG WITH BOARD LOCKS & 2 x 4-40 INSERTS, 0.38µm GOLD, RIGHT ANGLE	1-1634582-2
DESCRIPTION	TYCO PART No.

THIS DRAWING IS A CONTROLLED DOCUMENT.		DWN J.SANDWELL 15SEP2003	Tyco Electronics Corporation Stanmore, Middlesex, HA7 4RS															
DIMENSIONS: MM		CHK S.EBBUTT 15SEP2003																
TOLERANCES UNLESS OTHERWISE SPECIFIED:		APVD F.WHEELER-KING 15SEP2003	NAME 25 WAY D-SUB PLUG WITH BOARD LOCK															
<table border="1"> <tr><td>0 PLC</td><td>± -</td></tr> <tr><td>1 PLC</td><td>± -</td></tr> <tr><td>2 PLC</td><td>± -</td></tr> <tr><td>3 PLC</td><td>± -</td></tr> <tr><td>4 PLC</td><td>± -</td></tr> <tr><td>ANGLES</td><td>± -</td></tr> <tr><td>FINISH</td><td>-</td></tr> </table>		0 PLC	± -	1 PLC	± -	2 PLC	± -	3 PLC	± -	4 PLC	± -	ANGLES	± -	FINISH	-	PRODUCT SPEC -	-	
0 PLC	± -																	
1 PLC	± -																	
2 PLC	± -																	
3 PLC	± -																	
4 PLC	± -																	
ANGLES	± -																	
FINISH	-																	
MATERIAL SEE NOTE		APPLICATION SPEC -	SIZE A3	CAGE CODE 00779	DRAWING NO C-1634582	RESTRICTED TO -												
CUSTOMER DRAWING			SCALE NTS	SHEET 1 OF 2	REV B													

THIS DRAWING IS UNPUBLISHED. RELEASED FOR PUBLICATION OCT , 2003.
 © COPYRIGHT 2003 BY TYCO ELECTRONICS CORPORATION. ALL RIGHTS RESERVED.

LOC	DIST	REVISIONS			
P	LTR	DESCRIPTION	DATE	DWN	APVD
	B	SEE SHEET 1	-	-	-

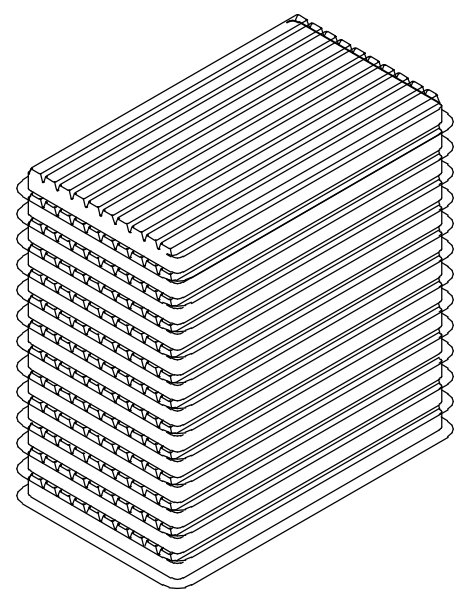

NOTES:
 1. DIMENSION:
 TRAY: L=310, W=220, H=23
 SHIPPING BOX: L=335, W=230, H=320
 2. QUANTITY:
 50 PCS/TRAY
 13 TRAY/SHIPPING BOX

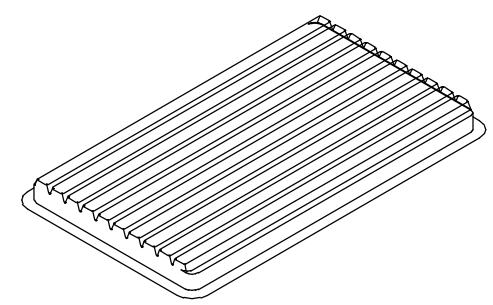

COVER

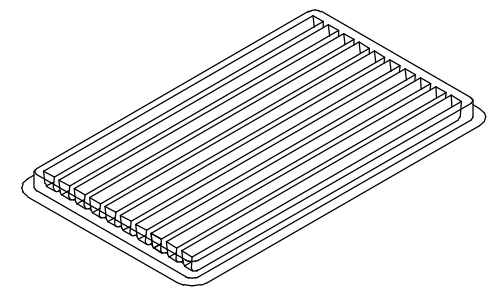

TRAY

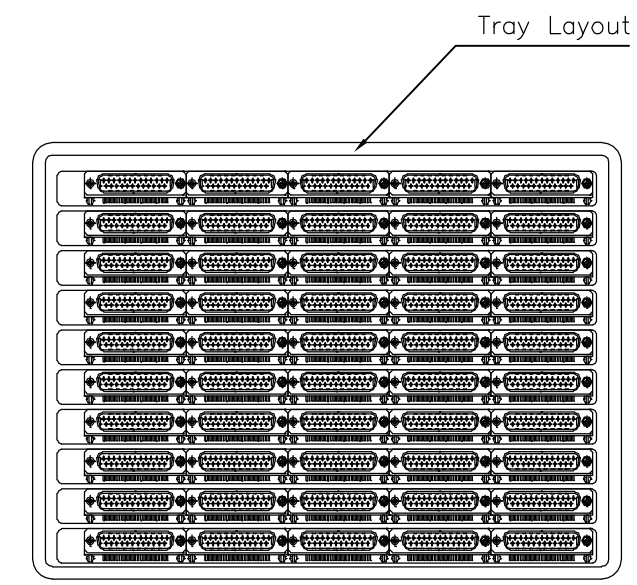
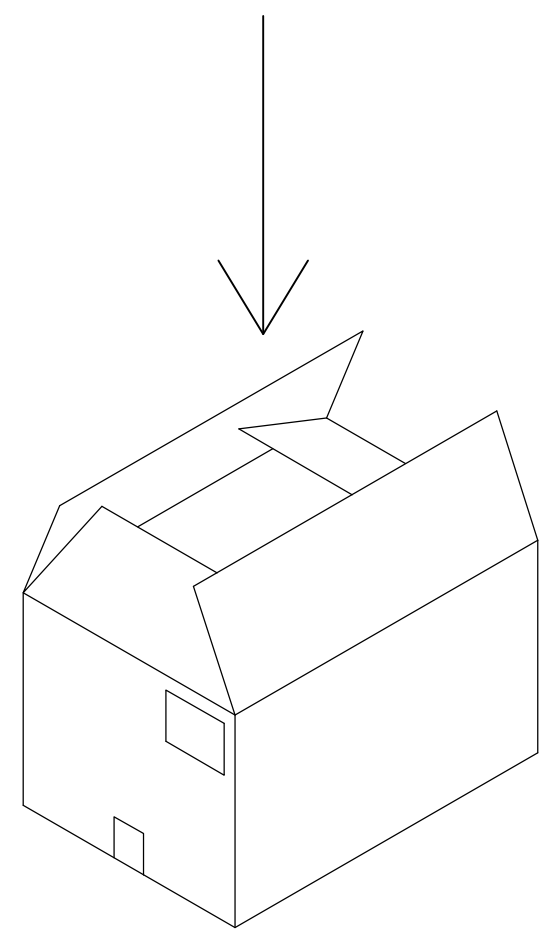

THIS DRAWING IS A CONTROLLED DOCUMENT.		DWN J. SANDWELL 15SEP2003	tyco Tyco Electronics Corporation													
DIMENSIONS: MM		CHK S. EBBUTT 15SEP2003	Stanmore, Middlesex, HA7 4RS													
TOLERANCES UNLESS OTHERWISE SPECIFIED:		APVD F. WHEELER-KING 15SEP2003	NAME 25 WAY D-SUB PLUG WITH BOARD LOCK													
<table border="1"> <tr><td>0 PLC</td><td>± -</td></tr> <tr><td>1 PLC</td><td>± -</td></tr> <tr><td>2 PLC</td><td>± -</td></tr> <tr><td>3 PLC</td><td>± -</td></tr> <tr><td>4 PLC</td><td>± -</td></tr> <tr><td>ANGLES</td><td>± -</td></tr> </table>		0 PLC	± -	1 PLC	± -	2 PLC	± -	3 PLC	± -	4 PLC	± -	ANGLES	± -	PRODUCT SPEC -	-	
0 PLC	± -															
1 PLC	± -															
2 PLC	± -															
3 PLC	± -															
4 PLC	± -															
ANGLES	± -															
MATERIAL SEE NOTE		FINISH -	APPLICATION SPEC -	RESTRICTED TO -												
		WEIGHT -	SIZE A3	CAGE CODE 00779												
		DRAWING NO C-1634582		SCALE NTS												
		CUSTOMER DRAWING		SHEET 2 OF 2												
				REV B												