

Features

- Lead free
- Absolute encoder / gray code output
- Digital output
- Sturdy construction
- Bushing mount
- Available with PC board mounting bracket (optional)



EAW - Absolute Contacting Encoder (ACE™)

General Information

Until now, the choice of an absolute encoder meant an expensive, and larger-sized product. Through the use of combinatorial mathematics, the gray-code pattern of the Bourns Absolute Contacting Encoder ACE™ is placed on a single track for a very economical, energy-efficient and compact product. Bourns' ACE™ provides an absolute digital output that will also retain its last position in the event of a power failure.

An intelligent alternative to incremental encoders and potentiometers, the Bourns ACE™ is ideally suited for many industrial, automotive, medical and consumer product applications.

Recommended Control Diagram for ACE-128

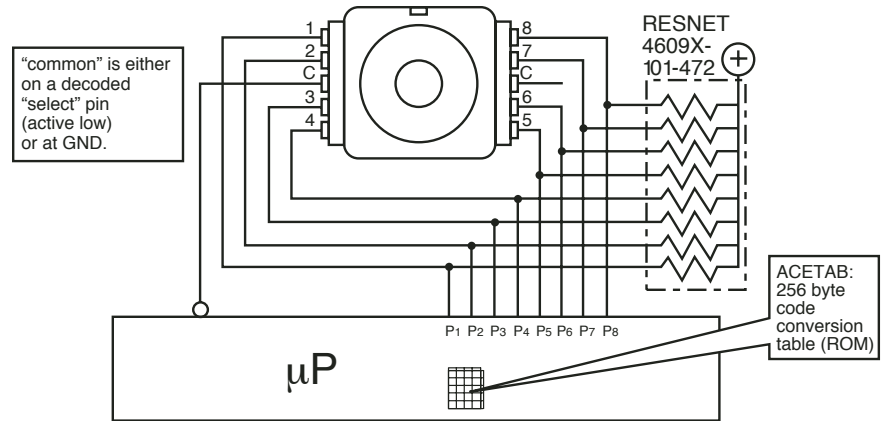

Electrical Characteristics

| | |
|--|--|
| Output | 8-bit gray code with 128 absolute states |
| Closed Circuit Resistance | 5 ohms maximum |
| Open Circuit Resistance | 100 K ohms minimum |
| Contact Rating..... | 10 milliamp @ 10 VDC or 0.1 watt maximum |
| Insulation Resistance (500 VDC)..... | 1,000 megohms minimum |
| Dielectric Withstanding Voltage (MIL-STD-202 Method 301) | |
| Sea Level | 1,000 VAC minimum |
| Electrical Travel..... | Continuous |
| Contact Bounce (60 RPM) | 2.7 milliseconds maximum* |
| RPM (Operating) | 120 maximum |

Environmental Characteristics

| | |
|-----------------------------------|---------------------------------------|
| Operating Temperature Range | +1 °C to +85 °C (+34 °F to +185 °F) |
| Storage Temperature Range..... | -40 °C to +85 °C (-40 °F to +185 °F) |
| Humidity..... | MIL-STD-202, Method 103B, Condition B |
| Vibration | 15 G |
| Contact Bounce | 0.1 millisecond maximum |
| Shock | 50 G |
| Contact Bounce | 0.1 millisecond maximum |
| Rotational Life | 50,000 shaft revolutions minimum |
| IP Rating | IP 40 |

Mechanical Characteristics

| | |
|--------------------------------|---|
| Mechanical Angle | 360 ° Continuous |
| Running Torque..... | 0.5 to 1.5 N-cm (0.75 to 2.50 oz-in.) |
| Mounting Torque..... | 79 N-cm (7 lb.-in.) maximum |
| Shaft Side Load (Static) | 4.5 kg (10 lbs.) minimum |
| Weight | Approximately 14 gms. (0.50 oz.) |
| Terminals | Printed circuit board terminals |
| Soldering Condition | |
| Manual Soldering | 96.5Sn/3.0Ag/0.5Cu solid wire or no-clean rosin cored wire 370 °C (700 °F) max. for 3 seconds |
| Wave Soldering | 96.5Sn/3.0Ag/0.5Cu solder with no-clean flux 260 °C (500 °F) max. for 5 seconds |
| Wash processes | Not recommended |
| Marking | Manufacturer's name and trademark, part number, and date code. |
| Hardware | One lockwasher and one mounting nut are shipped with each encoder, except where noted in the part number. |
| Packaging | 45 pcs./tray |

*High probability of missing gray codes with maximum bounce.

EAW - Absolute Contacting Encoder (ACE™)

BOURNS®

Pin Output Code For ACE-128

Bit/Pin correlation: b7 b6 b5 b4 b3 b2 b1 b0 = p8 p7 p6 p5 p4 p3 p2 p1

A binary "1" denotes an "open" switch and a binary "0" denotes a "closed" switch.

Positions 0-127 are seen by a clockwise rotation of the shaft.

| Position | p8 | p7 | p6 | p5 | p4 | p3 | p2 | p1 | Decimal Output |
|----------|----|----|----|----|----|----|----|----|----------------|
| 0 | 0 | 1 | 1 | 1 | 1 | 1 | 1 | 1 | 127 |
| 1 | 0 | 0 | 1 | 1 | 1 | 1 | 1 | 1 | 63 |
| 2 | 0 | 0 | 1 | 1 | 1 | 1 | 1 | 0 | 62 |
| 3 | 0 | 0 | 1 | 1 | 1 | 0 | 1 | 0 | 58 |
| 4 | 0 | 0 | 1 | 1 | 1 | 0 | 0 | 0 | 56 |
| 5 | 1 | 0 | 1 | 1 | 1 | 0 | 0 | 0 | 184 |
| 6 | 1 | 0 | 0 | 1 | 1 | 0 | 0 | 0 | 152 |
| 7 | 0 | 0 | 0 | 1 | 1 | 0 | 0 | 0 | 24 |
| 8 | 0 | 0 | 0 | 0 | 1 | 0 | 0 | 0 | 8 |
| 9 | 0 | 1 | 0 | 0 | 1 | 0 | 0 | 0 | 72 |
| 10 | 0 | 1 | 0 | 0 | 1 | 0 | 0 | 1 | 73 |
| 11 | 0 | 1 | 0 | 0 | 1 | 1 | 0 | 1 | 77 |
| 12 | 0 | 1 | 0 | 0 | 1 | 1 | 1 | 1 | 79 |
| 13 | 0 | 0 | 0 | 0 | 1 | 1 | 1 | 1 | 15 |
| 14 | 0 | 0 | 1 | 0 | 1 | 1 | 1 | 1 | 47 |
| 15 | 1 | 0 | 1 | 0 | 1 | 1 | 1 | 1 | 175 |
| 16 | 1 | 0 | 1 | 1 | 1 | 1 | 1 | 1 | 191 |
| 17 | 1 | 0 | 0 | 1 | 1 | 1 | 1 | 1 | 159 |
| 18 | 0 | 0 | 0 | 1 | 1 | 1 | 1 | 1 | 31 |
| 19 | 0 | 0 | 0 | 1 | 1 | 1 | 0 | 1 | 29 |
| 20 | 0 | 0 | 0 | 1 | 1 | 1 | 0 | 0 | 28 |
| 21 | 0 | 1 | 0 | 1 | 1 | 1 | 0 | 0 | 92 |
| 22 | 0 | 1 | 0 | 0 | 1 | 1 | 0 | 0 | 76 |
| 23 | 0 | 0 | 0 | 0 | 1 | 1 | 0 | 0 | 12 |
| 24 | 0 | 0 | 0 | 0 | 0 | 1 | 0 | 0 | 4 |
| 25 | 0 | 0 | 1 | 0 | 0 | 1 | 0 | 0 | 36 |
| 26 | 1 | 0 | 1 | 0 | 0 | 1 | 0 | 0 | 164 |
| 27 | 1 | 0 | 1 | 0 | 0 | 1 | 1 | 0 | 166 |
| 28 | 1 | 0 | 1 | 0 | 0 | 1 | 1 | 1 | 167 |
| 29 | 1 | 0 | 0 | 0 | 0 | 1 | 1 | 1 | 135 |
| 30 | 1 | 0 | 0 | 1 | 0 | 1 | 1 | 1 | 151 |
| 31 | 1 | 1 | 0 | 1 | 0 | 1 | 1 | 1 | 215 |
| 32 | 1 | 1 | 0 | 1 | 1 | 1 | 1 | 1 | 223 |
| 33 | 1 | 1 | 0 | 0 | 1 | 1 | 1 | 1 | 207 |
| 34 | 1 | 0 | 0 | 0 | 1 | 1 | 1 | 1 | 143 |
| 35 | 1 | 0 | 0 | 0 | 1 | 1 | 1 | 0 | 142 |
| 36 | 0 | 0 | 0 | 0 | 1 | 1 | 1 | 0 | 14 |
| 37 | 0 | 0 | 1 | 0 | 1 | 1 | 1 | 0 | 46 |
| 38 | 0 | 0 | 1 | 0 | 0 | 1 | 1 | 0 | 38 |
| 39 | 0 | 0 | 0 | 0 | 0 | 1 | 1 | 0 | 6 |
| 40 | 0 | 0 | 0 | 0 | 0 | 0 | 1 | 0 | 2 |
| 41 | 0 | 0 | 0 | 1 | 0 | 0 | 1 | 0 | 18 |
| 42 | 0 | 1 | 0 | 1 | 0 | 0 | 1 | 0 | 82 |
| 43 | 0 | 1 | 0 | 1 | 0 | 0 | 1 | 1 | 83 |
| 44 | 1 | 1 | 0 | 1 | 0 | 0 | 1 | 1 | 211 |
| 45 | 1 | 1 | 0 | 0 | 0 | 0 | 1 | 1 | 195 |
| 46 | 1 | 1 | 0 | 0 | 1 | 0 | 1 | 1 | 203 |
| 47 | 1 | 1 | 1 | 0 | 1 | 0 | 1 | 1 | 235 |
| 48 | 1 | 1 | 1 | 0 | 1 | 1 | 1 | 1 | 239 |
| 49 | 1 | 1 | 1 | 0 | 0 | 1 | 1 | 1 | 231 |
| 50 | 1 | 1 | 0 | 0 | 0 | 1 | 1 | 1 | 199 |
| 51 | 0 | 1 | 0 | 0 | 0 | 1 | 1 | 1 | 71 |
| 52 | 0 | 0 | 0 | 0 | 0 | 1 | 1 | 1 | 7 |
| 53 | 0 | 0 | 0 | 1 | 0 | 1 | 1 | 1 | 23 |
| 54 | 0 | 0 | 0 | 1 | 0 | 0 | 1 | 1 | 19 |
| 55 | 0 | 0 | 0 | 0 | 0 | 0 | 1 | 1 | 3 |
| 56 | 0 | 0 | 0 | 0 | 0 | 0 | 0 | 1 | 1 |
| 57 | 0 | 0 | 0 | 0 | 1 | 0 | 0 | 1 | 9 |
| 58 | 0 | 0 | 1 | 0 | 1 | 0 | 0 | 1 | 41 |
| 59 | 1 | 0 | 1 | 0 | 1 | 0 | 0 | 1 | 169 |
| 60 | 1 | 1 | 1 | 0 | 1 | 0 | 0 | 1 | 233 |
| 61 | 1 | 1 | 1 | 0 | 0 | 0 | 0 | 1 | 225 |
| 62 | 1 | 1 | 1 | 0 | 0 | 1 | 0 | 1 | 229 |
| 63 | 1 | 1 | 1 | 1 | 0 | 1 | 0 | 1 | 245 |

| Position | p8 | p7 | p6 | p5 | p4 | p3 | p2 | p1 | Decimal Output |
|----------|----|----|----|----|----|----|----|----|----------------|
| 64 | 1 | 1 | 1 | 1 | 0 | 1 | 1 | 1 | 247 |
| 65 | 1 | 1 | 1 | 1 | 0 | 0 | 1 | 1 | 243 |
| 66 | 1 | 1 | 1 | 0 | 0 | 0 | 1 | 1 | 227 |
| 67 | 1 | 0 | 1 | 0 | 0 | 0 | 1 | 1 | 163 |
| 68 | 1 | 0 | 0 | 0 | 0 | 0 | 1 | 1 | 131 |
| 69 | 1 | 0 | 0 | 0 | 1 | 0 | 1 | 1 | 139 |
| 70 | 1 | 0 | 0 | 0 | 1 | 0 | 0 | 1 | 137 |
| 71 | 1 | 0 | 0 | 0 | 0 | 0 | 0 | 1 | 129 |
| 72 | 1 | 0 | 0 | 0 | 0 | 0 | 0 | 0 | 128 |
| 73 | 1 | 0 | 0 | 0 | 0 | 1 | 0 | 0 | 132 |
| 74 | 1 | 0 | 0 | 1 | 0 | 1 | 0 | 0 | 148 |
| 75 | 1 | 1 | 0 | 1 | 0 | 1 | 0 | 0 | 212 |
| 76 | 1 | 1 | 1 | 1 | 0 | 1 | 0 | 0 | 244 |
| 77 | 1 | 1 | 1 | 1 | 0 | 0 | 0 | 0 | 240 |
| 78 | 1 | 1 | 1 | 1 | 0 | 0 | 1 | 0 | 242 |
| 79 | 1 | 1 | 1 | 1 | 1 | 0 | 1 | 0 | 250 |
| 80 | 1 | 1 | 1 | 1 | 1 | 0 | 1 | 1 | 251 |
| 81 | 1 | 1 | 1 | 1 | 1 | 0 | 0 | 1 | 249 |
| 82 | 1 | 1 | 1 | 1 | 0 | 0 | 0 | 1 | 241 |
| 83 | 1 | 1 | 0 | 1 | 0 | 0 | 0 | 1 | 209 |
| 84 | 1 | 1 | 0 | 0 | 0 | 0 | 0 | 1 | 193 |
| 85 | 1 | 1 | 0 | 0 | 0 | 1 | 0 | 1 | 197 |
| 86 | 1 | 1 | 0 | 0 | 0 | 1 | 0 | 0 | 196 |
| 87 | 1 | 1 | 0 | 0 | 0 | 0 | 0 | 0 | 192 |
| 88 | 0 | 1 | 0 | 0 | 0 | 0 | 0 | 0 | 64 |
| 89 | 0 | 1 | 0 | 0 | 0 | 0 | 1 | 0 | 66 |
| 90 | 0 | 1 | 0 | 0 | 1 | 0 | 1 | 0 | 74 |
| 91 | 0 | 1 | 1 | 0 | 1 | 0 | 1 | 0 | 106 |
| 92 | 0 | 1 | 1 | 1 | 1 | 0 | 1 | 0 | 122 |
| 93 | 0 | 1 | 1 | 1 | 1 | 0 | 0 | 0 | 120 |
| 94 | 0 | 1 | 1 | 1 | 1 | 0 | 0 | 1 | 121 |
| 95 | 0 | 1 | 1 | 1 | 1 | 1 | 0 | 1 | 125 |
| 96 | 1 | 1 | 1 | 1 | 1 | 1 | 0 | 1 | 253 |
| 97 | 1 | 1 | 1 | 1 | 1 | 1 | 0 | 0 | 252 |
| 98 | 1 | 1 | 1 | 1 | 1 | 0 | 0 | 0 | 248 |
| 99 | 1 | 1 | 1 | 0 | 1 | 0 | 0 | 0 | 232 |
| 100 | 1 | 1 | 1 | 0 | 0 | 0 | 0 | 0 | 224 |
| 101 | 1 | 1 | 1 | 0 | 0 | 0 | 1 | 0 | 226 |
| 102 | 0 | 1 | 1 | 0 | 0 | 0 | 1 | 0 | 98 |
| 103 | 0 | 1 | 1 | 0 | 0 | 0 | 0 | 0 | 96 |
| 104 | 0 | 0 | 1 | 0 | 0 | 0 | 0 | 0 | 32 |
| 105 | 0 | 0 | 1 | 0 | 0 | 0 | 0 | 1 | 33 |
| 106 | 0 | 0 | 1 | 0 | 0 | 1 | 0 | 1 | 37 |
| 107 | 0 | 0 | 1 | 1 | 0 | 1 | 0 | 1 | 53 |
| 108 | 0 | 0 | 1 | 1 | 1 | 1 | 0 | 1 | 61 |
| 109 | 0 | 0 | 1 | 1 | 1 | 1 | 0 | 0 | 60 |
| 110 | 1 | 0 | 1 | 1 | 1 | 1 | 0 | 0 | 188 |
| 111 | 1 | 0 | 1 | 1 | 1 | 1 | 1 | 0 | 190 |
| 112 | 1 | 1 | 1 | 1 | 1 | 1 | 1 | 0 | 254 |
| 113 | 0 | 1 | 1 | 1 | 1 | 1 | 1 | 0 | 126 |
| 114 | 0 | 1 | 1 | 1 | 1 | 1 | 0 | 0 | 124 |
| 115 | 0 | 1 | 1 | 1 | 0 | 1 | 0 | 0 | 116 |
| 116 | 0 | 1 | 1 | 1 | 0 | 0 | 0 | 0 | 112 |
| 117 | 0 | 1 | 1 | 1 | 0 | 0 | 0 | 1 | 113 |
| 118 | 0 | 0 | 1 | 1 | 0 | 0 | 0 | 1 | 49 |
| 119 | 0 | 0 | 1 | 1 | 0 | 0 | 0 | 0 | 48 |
| 120 | 0 | 0 | 0 | 1 | 0 | 0 | 0 | 0 | 16 |
| 121 | 1 | 0 | 0 | 1 | 0 | 0 | 0 | 0 | 144 |
| 122 | 1 | 0 | 0 | 1 | 0 | 0 | 1 | 0 | 146 |
| 123 | 1 | 0 | 0 | 1 | 1 | 0 | 1 | 0 | 154 |
| 124 | 1 | 0 | 0 | 1 | 1 | 1 | 1 | 0 | 158 |
| 125 | 0 | 0 | 0 | 1 | 1 | 1 | 1 | 0 | 30 |
| 126 | 0 | 1 | 0 | 1 | 1 | 1 | 1 | 0 | 94 |
| 127 | 0 | 1 | 0 | 1 | 1 | 1 | 1 | 1 | 95 |

EAW - Absolute Contacting Encoder (ACE™)

BOURNS®

Dimensional Drawings

Bushing Mounted: Housing A with Rear Facing Terminals

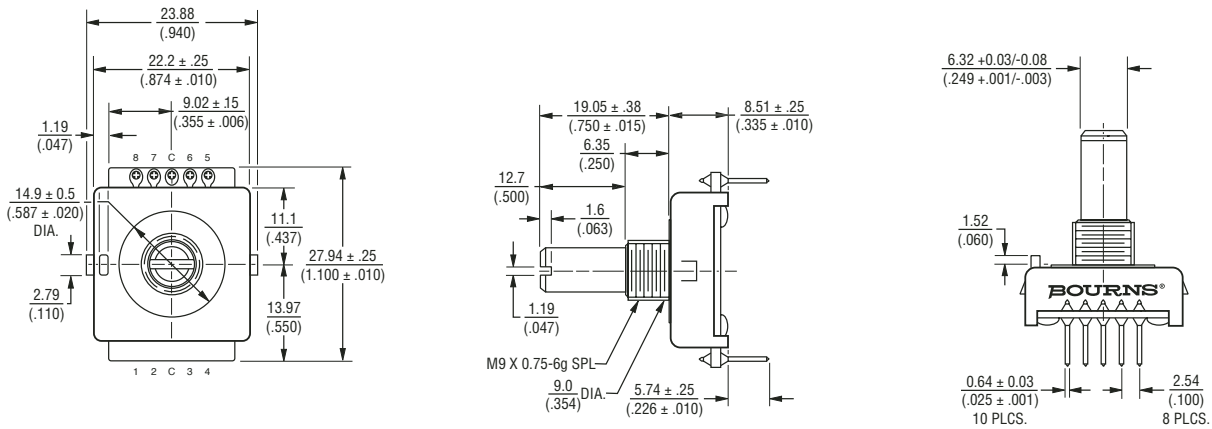

Bushing Mounted: Housing A with Forward Facing Terminals

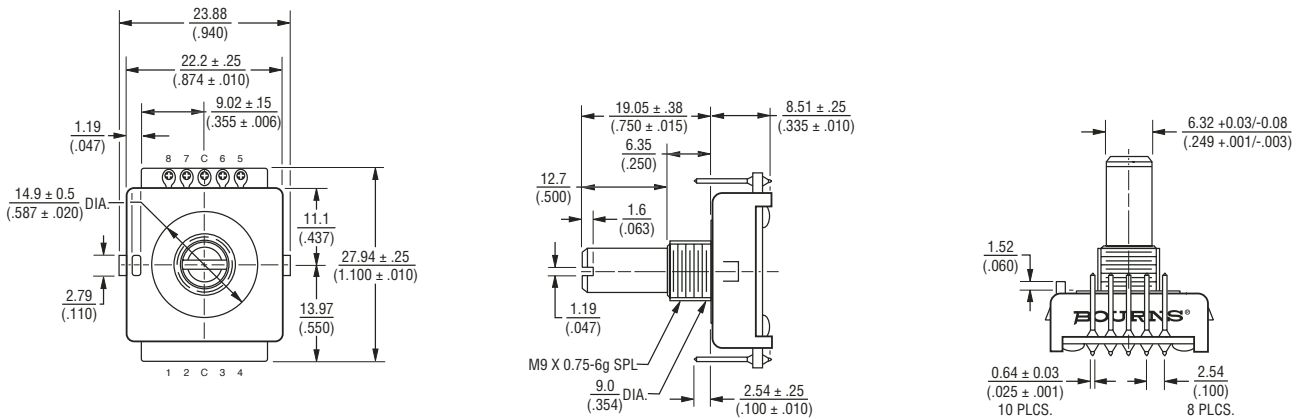

PCB Bracket Mounted: Housing B

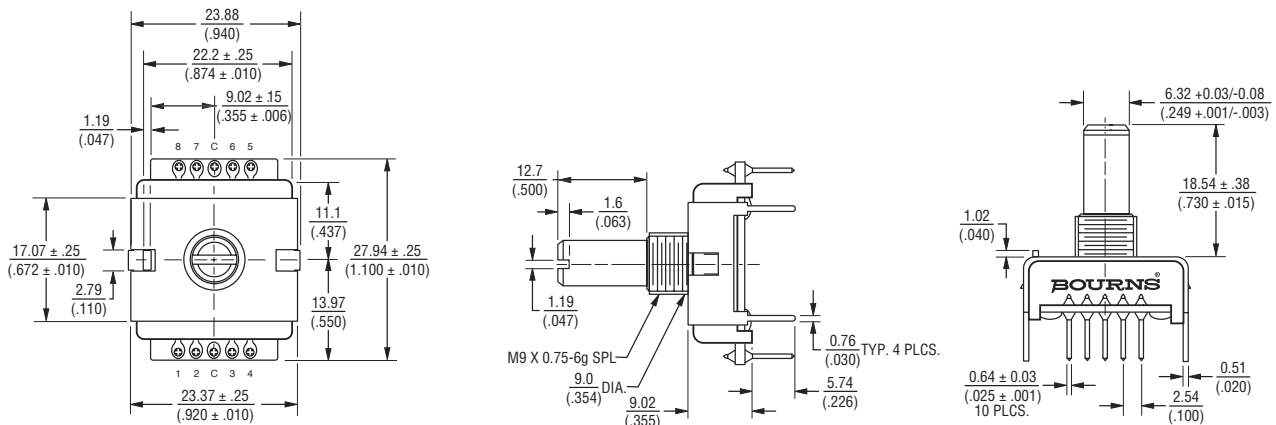

Specifications are subject to change without notice. Customers should verify actual device performance in their specific applications.

EAW - Absolute Contacting Encoder (ACE™)

BOURNS®

Dimensional Drawings

Shaft Style **B**

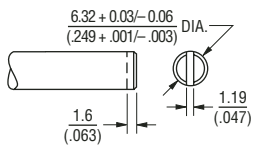

Shaft Style **C**

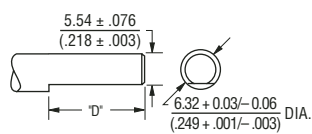

D DIMENSION EXTENDS FROM SHAFT END TO BUSHING FACE
 D = (SHAFT LENGTH, FMS) - (BUSHING LENGTH)

Shaft Style **R**

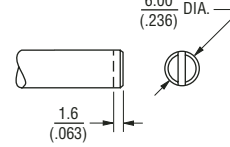

Bushing Mounted: Housing A with Rear Facing Terminals

Panel Hole Dimensions

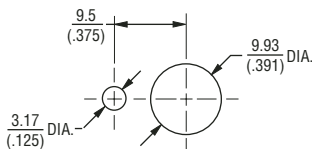

PCB Board Hole Pattern w/PCB Bracket

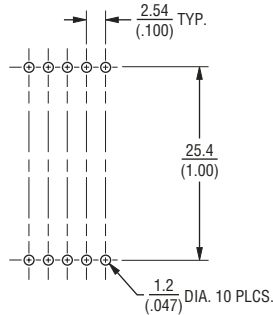

Bushing Mounted: Housing A with Forward Facing Terminals

PCB Board Hole Pattern w/PCB Bracket

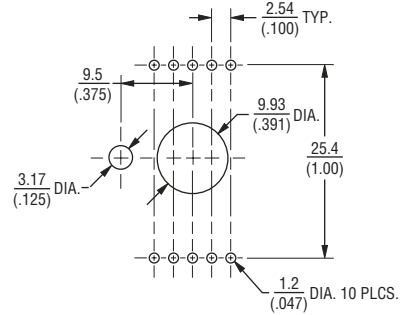

PCB Bracket Mounted: Housing B

Panel Hole Dimensions

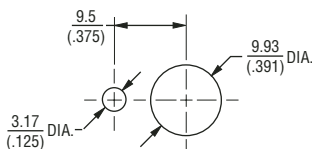

PCB Board Hole Pattern w/PCB Bracket

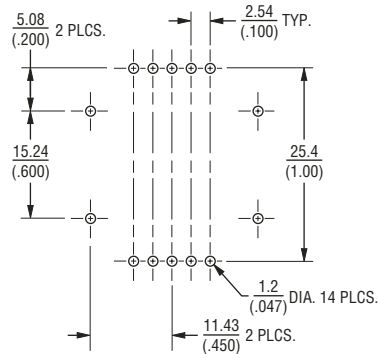

TOLERANCES EXCEPT WHERE NOTED:

.XX = ± $\frac{.51}{(.02)}$.XXX = ± $\frac{.127}{(.005)}$

DIMENSIONS: $\frac{MM}{(IN)}$

EAW - Absolute Contacting Encoder (ACE™)

BOURNS®

How to Order

PART NUMBERING SYSTEM

E A W 0 J - B 2 4 - A E 0 1 2 8 L

| Code | Rotational Life |
|------|--------------------|
| A | 50,000 Revolutions |

| BUSHING CONFIGURATION | |
|-----------------------|--|
| Code | Description |
| W | 9 mm x 1/4 " Length. Threaded M9x0.75 |
| L | 9 mm x 3/8 " Length. Threaded M9x0.75 (Use B shaft only.) |

| DETENT CONFIGURATION | |
|----------------------|--------------|
| Code | Description |
| 0 | Non-Detented |

| ANTI-ROTATION LUG POSITION | |
|----------------------------|---------------|
| Code | Description |
| J | 9:00 Position |
| D | None |

| SHAFT STYLE (See Outline Drawing for Details) | |
|---|---------------------------------------|
| Code | Description |
| B | Plain with Inserted Slot (1/4 " Dia.) |
| C | Single Flatted (1/4 " Dia.) |
| R | Plain with Inserted Slot (6 mm Dia.) |

| Code | Description |
|------|-------------|
| L | Lead Free |

| PERFORMANCE CODE | | |
|------------------|---------|-------------|
| Code | Detents | States/Rev. |
| E0128 | 0 | 128 |

| HOUSING TERMINAL CONFIGURATION (X indicates "Equipped With") | | | | | |
|---|------|---|---|---|---|
| Features | Code | | | | |
| | A | B | C | H | K |
| Rear Mount Terminals | X | X | X | | |
| Forward Facing Terminals | | | | X | X |
| PCB Bracket | | X | X | | |
| Hardware Included | X | | X | X | |

| SHAFT LENGTH (FMS) | | |
|--------------------|-------------------------|------------------------|
| Code | Description | Available Shaft Styles |
| 24 | 3/4 " (19.05 mm) Length | B, C |
| Metric | | |
| 19 | 19 mm Length | R |

The sample part number demonstrates the identification code for Bourns contacting encoders. The part number shown is a commonly used model, typically available from stock.

*Consult factory concerning special inquiries.



Sensors & Controls Division

Asia-Pacific:

TEL +886-2 25624117

FAX +886-2 25624116

Europe:

TEL +41-41 7685555

FAX +41-41 7685510

The Americas:

TEL +1-951 781-5500

FAX +1-951 781-5700

www.bourns.com