

## FEATURES

- **Ultralow Quiescent Current: 2.8 $\mu$ A Typ (LTC1440)**
- **Wide Supply Range:**
  - Single: 2V to 11V
  - Dual:  $\pm 1$ V to  $\pm 5.5$ V
- **Input Voltage Range Includes the Negative Supply**
- **Reference Output Drives 0.01 $\mu$ F Capacitor**
- **Adjustable Hysteresis (LTC1440/LTC1442)**
- **TTL/CMOS Compatible Outputs**
- **12 $\mu$ s Propagation Delay with 10mV Overdrive**
- **No Crowbar Current**
- **40mA Continuous Source Current**
- **Pin Compatible Upgrades for MAX921/922/923**

## APPLICATIONS

- Battery-Powered System Monitoring
- Threshold Detectors
- Window Comparators
- Oscillator Circuits

 LTC and LT are registered trademarks of Linear Technology Corporation.

## DESCRIPTION

The LTC<sup>®</sup>1440/LTC1441/LTC1442 are ultralow power single and dual comparators with built-in references. The comparators feature less than 4.7 $\mu$ A supply current over temperature (LTC1440), a 1.182V  $\pm 1\%$  reference, programmable hysteresis (LTC1440/LTC1442) and TTL/CMOS outputs that sink and source current. The reference output can drive a bypass capacitor of up to 0.01 $\mu$ F without oscillation.

The comparators operate from a single 2V to 11V supply or a dual  $\pm 1$ V to  $\pm 5.5$ V supply (LTC1440). Comparator hysteresis is easily programmed by using two resistors and the HYST pin (LTC1440/LTC1442). Each comparator's input operates from the negative supply to within 1.3V of the positive supply. The comparator output stage can continuously source up to 40mA. By eliminating the cross-conducting current that normally happens when the comparator changes logic states, the power supply glitches are eliminated.

The LTC1440/LTC1441/LTC1442 are available in the 8-pin PDIP and SO packages.

## TYPICAL APPLICATION

Micropower 2.9V  $V_{CC}$  Threshold Detector

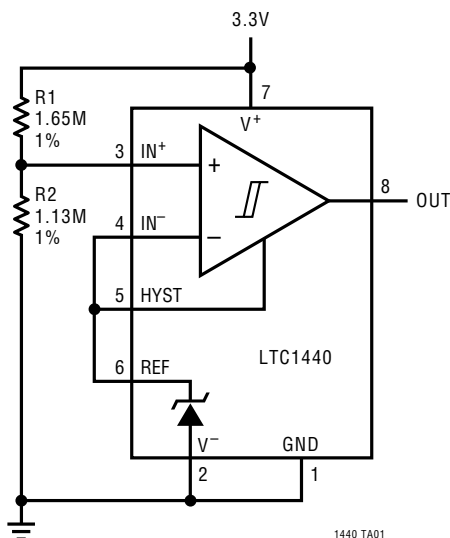

LTC1440 Supply Current vs Temperature

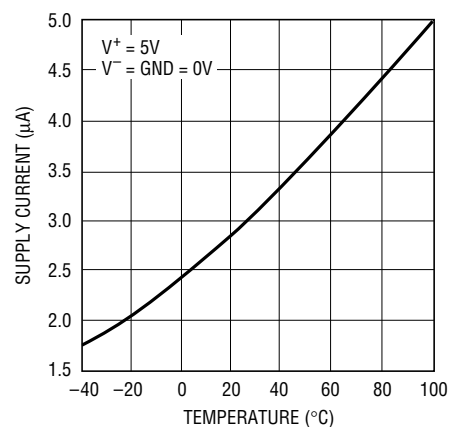

1440/1/2 TA02

# LTC1440/LTC1441/LTC1442

## ABSOLUTE MAXIMUM RATINGS

### Voltage

$V^+$  to  $V^-$ ,  $V^+$  to GND, GND to  $V^-$  ..... 12V to  $-0.3V$   
 $IN^+$ ,  $IN^-$ , HYST ..... ( $V^+ + 0.3V$ ) to ( $V^- - 0.3V$ )  
 REF ..... ( $V^+ + 0.3V$ ) to ( $V^- - 0.3V$ )  
 OUT (LTC1440) ..... ( $V^+ + 0.3V$ ) to (GND  $- 0.3V$ )  
 OUT (LTC1441/LTC1442) ... ( $V^+ + 0.3V$ ) to ( $V^- - 0.3V$ )

### Current

$IN^+$ ,  $IN^-$ , HYST ..... 20mA  
 REF ..... 20mA  
 OUT ..... 50mA

OUT Short-Circuit Duration ( $V^+ \leq 5.5V$ ) ..... Continuous  
 Power Dissipation ..... 500mW  
 Operating Temperature Range  
 LTC144XC .....  $0^\circ C$  to  $70^\circ C$   
 LTC144XI .....  $-40^\circ C$  to  $85^\circ C$   
 Storage Temperature Range .....  $-65^\circ C$  to  $150^\circ C$   
 Lead Temperature (Soldering, 10 sec) .....  $300^\circ C$

## PACKAGE/ORDER INFORMATION

LTC1440		LTC1441		LTC1442	
ORDER PART NUMBER	S8 PART MARKING	ORDER PART NUMBER	S8 PART MARKING	ORDER PART NUMBER	S8 PART MARKING
LTC1440CN8	1440	LTC1441CN8	1441	LTC1442CN8	1442
LTC1440CS8	1440I	LTC1441CS8	1441I	LTC1442CS8	1442I
LTC1440IN8		LTC1441IN8		LTC1442IN8	
LTC1440IS8		LTC1441IS8		LTC1442IS8	

Consult factory for Military grade parts.

## ELECTRICAL CHARACTERISTICS $V^+ = 5V$ , $V^- = GND = 0V$ , $T_A = 25^\circ C$ unless otherwise noted.

SYMBOL	PARAMETER	CONDITIONS	MIN	TYP	MAX	UNITS
<b>Power Supply</b>						
$V^+$	Supply Voltage Range		●	2.0	11.0	V
$I_{CC}$	Supply Current	$IN^+ = IN^- = 80mV$ HYST = REF (LTC1440/LTC1442)	●	2.8	4.7	$\mu A$
		LTC1440	●	3.5	5.7	$\mu A$
		LTC1441	●	3.5	5.7	$\mu A$
		LTC1442	●	3.5	5.7	$\mu A$
<b>Comparator</b>						
$V_{OS}$	Comparator Input Offset Voltage	$V_{CM} = 2.5V$	●	$\pm 3$	$\pm 10$	mV
$I_{IN}$	Input Leakage Current ( $IN^+$ , $IN^-$ )	$V_{IN^+} = V_{IN^-} = 2.5V$	●	$\pm 0.01$	$\pm 1.0$	nA
	Input Leakage Current (HYST)		●	$\pm 0.02$	$\pm 1.0$	nA

**ELECTRICAL CHARACTERISTICS**  $V^+ = 5V$ ,  $V^- = GND = 0V$ ,  $T_A = 25^\circ C$  unless otherwise noted.

SYMBOL	PARAMETER	CONDITIONS		MIN	TYP	MAX	UNITS
$V_{CM}$	Comparator Input Common Mode Range		●	$V^-$		$V^+ - 1.3V$	V
CMRR	Common Mode Rejection Ratio	$V^-$ to $V^+ - 1.3V$			0.1	1	mV/V
PSRR	Power Supply Rejection Ratio	$V^+ = 2V$ to 11V			0.1	1	mV/V
NOISE	Voltage Noise	100Hz to 100kHz			100		$\mu V_{RMS}$
$V_{HYST}$	Hysteresis Input Voltage Range	LTC1440/LTC1442	●	REF - 50mV		REF	V
$t_{PD}$	Propagation Delay	$C_{OUT} = 100pF$			12		$\mu s$
		Overdrive = 10mV			4		$\mu s$
		Overdrive = 100mV					
$V_{OH}$	Output High Voltage	$I_O = -13mA$	●	$V^+ - 0.4V$			V
$V_{OL}$	Output Low Voltage	$I_O = 1.8mA$	●			GND + 0.4V	V
		LTC1440	●			$V^- + 0.4V$	V
		LTC1441/LTC1442	●				V

**Reference**

$V_{REF}$	Reference Voltage	No Load LTC1440/LTC1442	C Temp Range	●	1.170	1.182	1.194	V
			I Temp Range	●	1.164		1.2	V
$I_{SOURCE}$	Reference Output Source Current	$\Delta V_{REF} \leq 1mV$	●	100	200		$\mu A$	
$I_{SINK}$	Reference Output Sink Current	$\Delta V_{REF} \leq 2.5mV$		10	20		$\mu A$	
NOISE	Voltage Noise	100Hz to 100kHz			100		$\mu V_{RMS}$	

 $V^+ = 3V$ ,  $V^- = GND = 0V$ ,  $T_A = 25^\circ C$  unless otherwise noted.**Power Supply**

$V^+$	Supply Voltage Range		●	2		11	V	
$I_{CC}$	Supply Current	$I_{IN^+} = I_{IN^-} = 80mV$ HYST = REF (LTC1440/LTC1442)	LTC1440	●		2.8	4.7	$\mu A$
			LTC1441	●		3.5	5.7	$\mu A$
			LTC1442	●		3.5	5.7	$\mu A$

**Comparator**

$V_{OS}$	Comparator Input Offset Voltage	$V_{CM} = 1.5V$	●		$\pm 3$	$\pm 10$	mV	
$I_{IN}$	Input Leakage Current ( $I_{IN^+}$ , $I_{IN^-}$ )	$V_{IN^+} = V_{IN^-} = 1.5V$	●		$\pm 0.01$	$\pm 1$	nA	
	Input Leakage Current (HYST)		●		$\pm 0.02$	$\pm 1$	nA	
$V_{CM}$	Comparator Input Common Mode Range		●	$V^-$		$V^+ - 1.3V$	V	
CMRR	Common Mode Rejection Ratio	$V^-$ to $V^+ - 1.3V$			0.1	1	mV/V	
PSRR	Power Supply Rejection Ratio	$V^+ = 2V$ to 11V			0.1	1	mV/V	
NOISE	Voltage Noise	100Hz to 100kHz			100		$\mu V_{RMS}$	
$V_{HYST}$	Hysteresis Input Voltage Range	LTC1440/LTC1442	●	REF - 50mV		REF	V	
$t_{PD}$	Propagation Delay	$C_{OUT} = 100pF$			14		$\mu s$	
			Overdrive = 10mV		5		$\mu s$	
	Overdrive = 100mV							
$V_{OH}$	Output High Voltage	$I_O = -8mA$	●	$V^+ - 0.4V$			V	
$V_{OL}$	Output Low Voltage	$I_O = 0.8mA$	LTC1440	●			GND + 0.4V	V
			LTC1441/LTC1442	●			$V^- + 0.4V$	V

**Reference**

$V_{REF}$	Reference Voltage	No Load LTC1440/LTC1442	C Temp Range	●	1.170	1.182	1.194	V
			I Temp Range	●	1.164		1.2	V
$I_{SOURCE}$	Reference Output Source Current	$\Delta V_{REF} \leq 1mV$	●	60	120		$\mu A$	
$I_{SINK}$	Reference Output Sink Current	$\Delta V_{REF} \leq 2.5mV$		10	20		$\mu A$	
NOISE	Voltage Noise	100Hz to 100kHz			100		$\mu V_{RMS}$	

The ● denotes specifications which apply over the full operating temperature range.

# TYPICAL PERFORMANCE CHARACTERISTICS

**Comparator Response Time vs Input Overdrive**

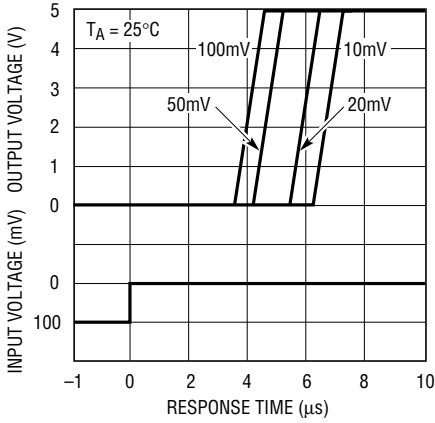

1440/1/2 G01

**Comparator Response Time vs Input Overdrives**

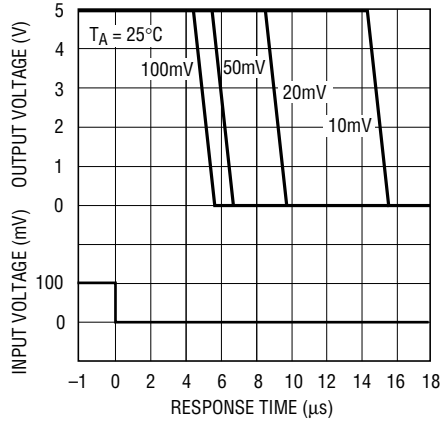

1440/1/2 G02

**Comparator Short-Circuit Sink Current vs Supply Voltage**

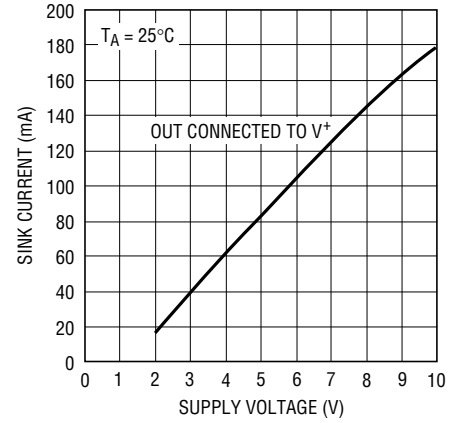

1440/1/2 G03

**Comparator Short-Circuit Source Current vs Supply Voltage**

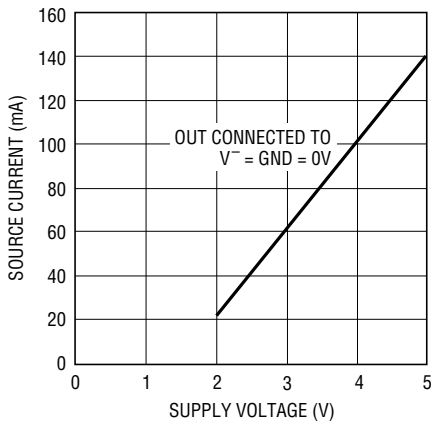

1440/1/2 G04

**Comparator Response Time vs Load Capacitance with 100mV Input Overdrive**

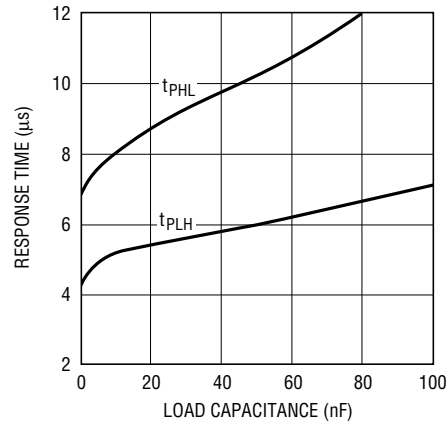

1440/1/2 G05

**Comparator Response Time at Low Supply Voltage**

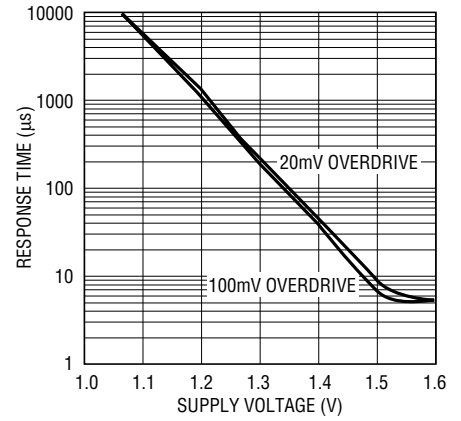

1440/1/2 G06

**Comparator Output Voltage High vs Load Current**

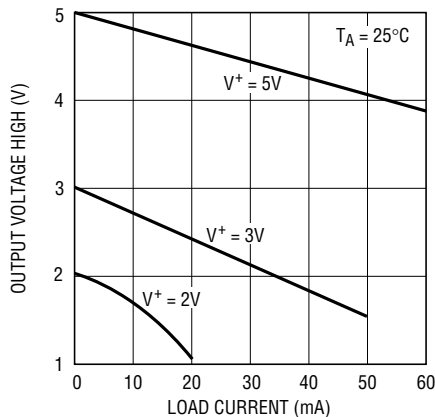

1440/1/2 G07

**Comparator Output Voltage Low vs Load Current**

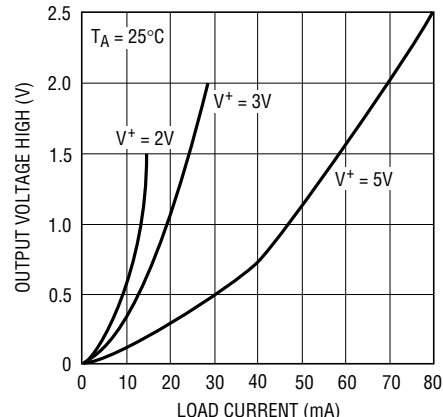

1440/1/2 G08

# TYPICAL PERFORMANCE CHARACTERISTICS

**LTC1440/LTC1442  
Hysteresis Control**

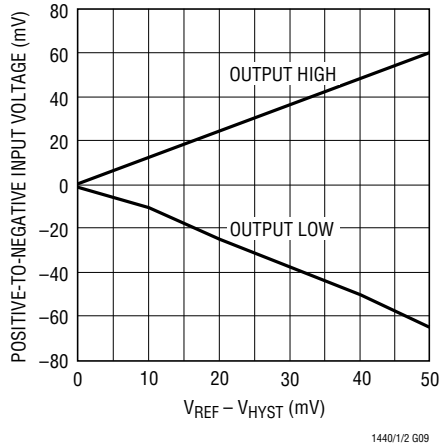

1440/1/2 G09

**LTC1440  
Supply Current vs Temperature**

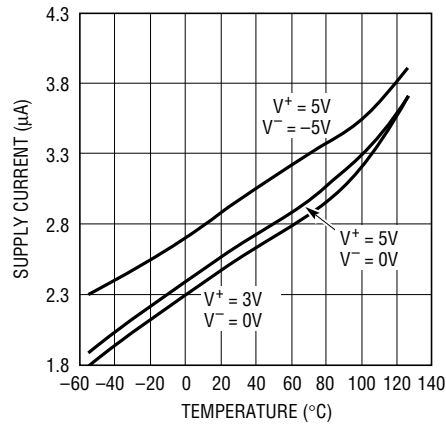

1440/1/2 G10

**Reference Output Voltage vs  
Output Load Current**

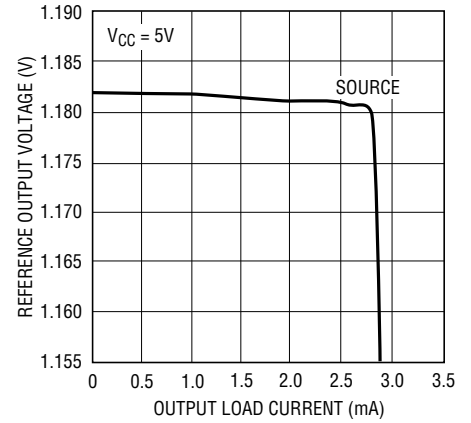

1440/1/2 G11

**Reference Output Voltage vs  
Output Load Current (Sink)**

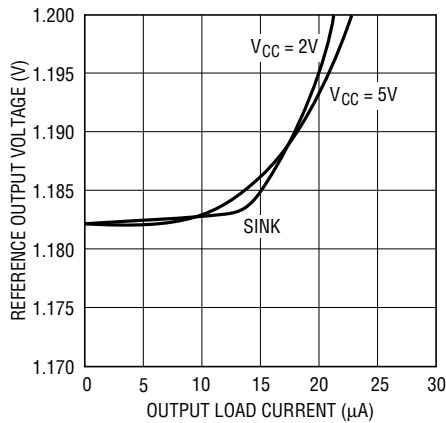

1440/1/2 G12

**Reference Voltage vs  
Temperature**

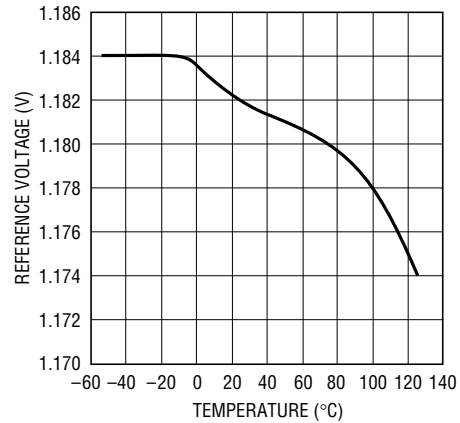

1440/1/2 G13

## PIN FUNCTIONS

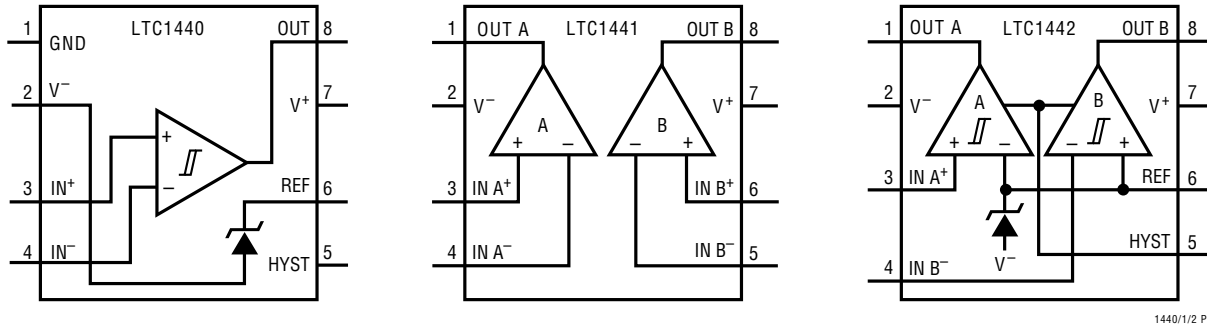

### LTC1440

**GND (Pin 1):** Ground. Connect to  $V^-$  for single supply operation.

**$V^-$  (Pin 2):** Negative Supply. Connect to ground for single supply operation. Potential should be more negative than GND.

**$IN^+$  (Pin 3):** Noninverting Comparator Input. Input common mode range from  $V^-$  to  $V^+ - 1.3V$ . Input current typically 10pA at 25°C.

**$IN^-$  (Pin 4):** Inverting Comparator Input. Input common mode range from  $V^-$  to  $V^+ - 1.3V$ . Input current typically 10pA at 25°C.

**HYST (Pin 5):** Hysteresis Input. Connect to REF if not used. Input voltage range is from  $V_{REF}$  to  $V_{REF} - 50mV$ .

**REF (Pin 6):** Reference Output. 1.182V with respect to  $V^-$ . Can source up to 200 $\mu$ A and sink 15 $\mu$ A at 25°C. Drive 0.01 $\mu$ F bypass capacitor without oscillation.

**$V^+$  (Pin 7):** Positive Supply. 2V to 11V.

**OUT (Pin 8):** Comparator CMOS Output. Swings from GND to  $V^+$ . Output can source up to 40mA and sink 5mA.

### LTC1441

**OUT A (Pin 1):** Comparator A CMOS Output. Swings from  $V^-$  to  $V^+$ . Output can source up to 40mA and sink 5mA.

**$V^-$  (Pin 2):** Negative Supply.

**$IN A^+$  (Pin 3):** Noninverting Input of Comparator A. Input common mode range from  $V^-$  to  $V^+ - 1.3V$ . Input current typically 10pA at 25°C.

**$IN A^-$  (Pin 4):** Inverting Input of Comparator A. Input common mode range from  $V^-$  to  $V^+ - 1.3V$ . Input current typically 10pA at 25°C.

**$IN B^-$  (Pin 5):** Inverting Input of Comparator B. Input common mode range from  $V^-$  to  $V^+ - 1.3V$ . Input current typically 10pA at 25°C.

**$IN B^+$  (Pin 6):** Noninverting Input of Comparator B. Input common mode range from  $V^-$  to  $V^+ - 1.3V$ . Input current typically 10pA at 25°C.

**$V^+$  (Pin 7):** Positive Supply. 2V to 11V.

**OUT B (Pin 8):** Comparator B CMOS Output. Swings from  $V^-$  to  $V^+$ . Output can source up to 40mA and sink 5mA.

### LTC1442

**OUT A (Pin 1):** Comparator A CMOS Output. Swings from  $V^-$  to  $V^+$ . Output can source up to 40mA and sink 5mA.

**$V^-$  (Pin 2):** Negative Supply.

**$IN A^+$  (Pin 3):** Noninverting Input of Comparator A. Input common mode range from  $V^-$  to  $V^+ - 1.3V$ . Input current typically 10pA at 25°C.

**$IN B^-$  (Pin 4):** Inverting Input of Comparator B. Input common mode range from  $V^-$  to  $V^+ - 1.3V$ . Input current typically 10pA at 25°C.

**HYST (Pin 5):** Hysteresis Input. Connect to REF if not used. Input voltage range is from  $V_{REF}$  to  $V_{REF} - 50mV$ .

**REF (Pin 6):** Reference Output. 1.182V with respect to  $V^-$ . Can source up to 200 $\mu$ A and sink 15 $\mu$ A at 25°C. Drive 0.01 $\mu$ F bypass capacitor without oscillation.

**$V^+$  (Pin 7):** Positive Supply. 2V to 11V.

**OUT B (Pin 8):** Comparator B CMOS Output. Swings from  $V^-$  to  $V^+$ . Output can source up to 40mA and sink 5mA.

## APPLICATIONS INFORMATION

LTC1440/LTC1441/LTC1442 are a family of micropower comparators with built-in 1.182V reference. Features include programmable hysteresis (LTC1440/LTC1442), wide supply voltage range (2V to 11V) and the ability of the reference to drive up to a 0.01 $\mu$ F capacitor without oscillation. The comparators' CMOS outputs can source up to 40mA and the supply current glitches, that normally occur when switching logic states, have been eliminated.

### Power Supplies

The comparator family operates from a single 2V to 11V supply. The LTC1440 includes a separate ground for the comparator output stage, allowing a split supply ranging from  $\pm 1$ V to  $\pm 5.5$ V. Connecting  $V^-$  to GND on the LTC1440 will allow single supply operation. If the comparator output is required to source more than 1mA, or the supply source impedance is high,  $V^+$  should be bypassed with a 0.1 $\mu$ F capacitor.

### Comparator Inputs

The comparator inputs can swing from the negative supply  $V^-$  to within 1.3V max of the positive supply  $V^+$ . The inputs can be forced 300mV below  $V^-$  or above  $V^+$  without damage and the typical input leakage current is only  $\pm 10$ pA.

### Comparator Outputs

The LTC1440 comparator output swings between GND and  $V^+$  to assure TTL compatibility with a split supply. The LTC1441 and LTC1442 outputs swing between  $V^-$  and  $V^+$ . The outputs are capable of sourcing up to 40mA and sinking up to 5mA while still maintaining microampere quiescent currents. The output stage does not generate crowbar switching currents during transitions which helps minimize parasitic feedback through the supply pins.

### Voltage Reference

The internal bandgap reference has a voltage of 1.182V referenced to  $V^-$ . The reference accuracy is 1.5% from  $-40^\circ\text{C}$  to  $85^\circ\text{C}$ . It can source up to 200 $\mu$ A and sink up to 20 $\mu$ A with a 5V supply. The reference can drive a bypass

capacitor of up to 0.01 $\mu$ F without oscillation and by inserting a series resistor, capacitance values up to 100 $\mu$ F can be used (Figure 1).

Figure 2 shows the resistor value required for different capacitor values to achieve critical damping. Bypassing the reference can help prevent false tripping of the comparators by preventing glitches on  $V^+$  or reference load transients from disturbing the reference output voltage.

Figure 3 shows the bypassed reference output with a square wave applied to the  $V^+$  pin. Resistors R2 and R3 set 10mV of hysteresis voltage band while R1 damps the reference response. Note that the comparator output doesn't trip.

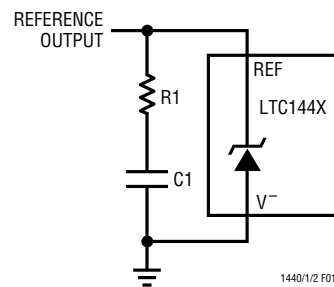

Figure 1. Damping the Reference Output

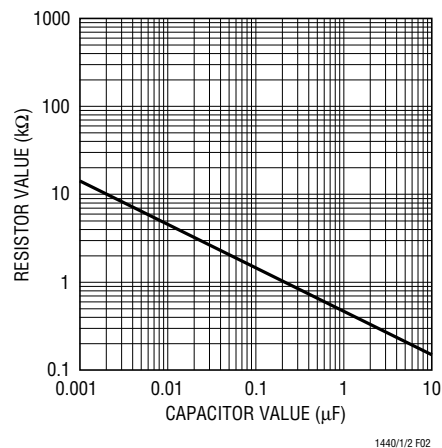

Figure 2. Damping Resistance vs Bypass Capacitor Value

APPLICATIONS INFORMATION

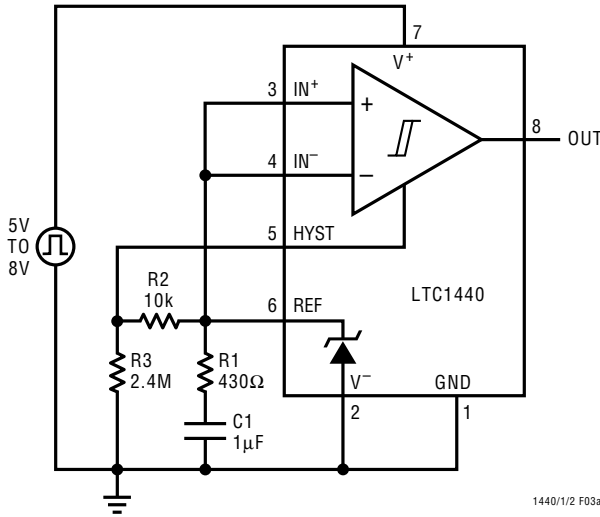

Figure 3a. V+ Glitching Test Circuit

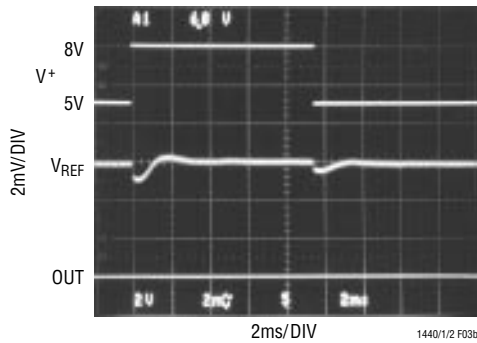

Figure 3b. V+ Glitching Response

Hysteresis

Hysteresis can be added to the LTC1440 by connecting a resistor (R1) between the REF and HYST pins and a second resistor (R2) from HYST to V- (Figure 4).

The difference between the upper and lower threshold voltages, or hysteresis voltage band (V<sub>HB</sub>), is equal to twice the voltage difference between the REF and HYST pins.

When more hysteresis is added, the upper threshold increases the same amount as the low threshold decreases. The maximum voltage allowed between REF and HYST pins is 50mV, producing a maximum hysteresis voltage band of 100mV. The hysteresis band could vary by

up to 15%. If hysteresis is not wanted, the HYST pin should be shorted to REF. Acceptable values for I<sub>REF</sub> range from 0.1μA to 5μA. If 2.4M is chosen for R2, then the value of R1 is equal to the value of V<sub>HB</sub>.

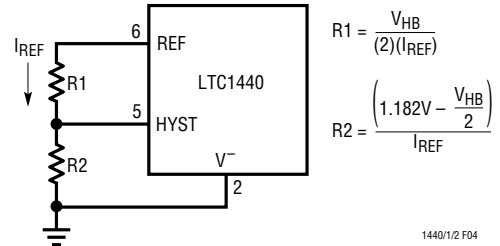

Figure 4. Programmable Hysteresis

Level Detector

The LTC1440 is ideal for use as a micropower level detector as shown in Figure 5. R1 and R2 form a voltage divider from V<sub>IN</sub> to the noninverting comparator input. R3 and R4 set the hysteresis voltage, and R5 and C1 bypass the reference output. The following design procedure can be used to select the component values:

1. Choose the V<sub>IN</sub> voltage trip level, in this example 4.65V.

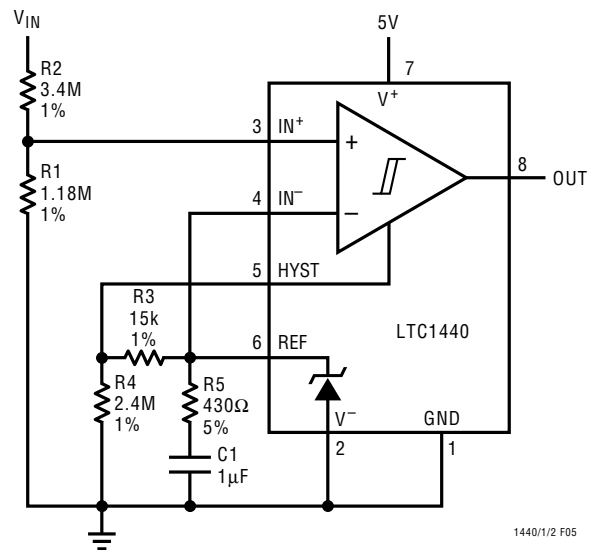

Figure 5. Glitch-Free Level Detector with Hysteresis



## APPLICATIONS INFORMATION

2. Calculate the required resistive divider ratio.

$$\text{Ratio} = V_{\text{REF}}/V_{\text{IN}}$$

$$\text{Ratio} = 1.182\text{V}/4.65\text{V} = 0.254$$

3. Choose the required hysteresis voltage band at the input  $V_{\text{HBIN}}$ , in this example 60mV. Calculate the hysteresis voltage band referred to the comparator input  $V_{\text{HB}}$ .

$$V_{\text{HB}} = (V_{\text{HBIN}})(\text{Ratio})$$

$$V_{\text{HB}} = (60\text{mV})(0.254)$$

$$V_{\text{HB}} = 15.24\text{mV}$$

4. Choose the values for R3 and R4 to set the hysteresis.

$$R4 = 2.4\text{M}$$

$$R3(\text{k}\Omega) = V_{\text{HB}} = 15\text{k}$$

5. Choose the values for R1 and R2 to set the trip point.

$$R1 = \frac{V_{\text{REF}}}{I_{\text{BIAS}}} = \frac{1.182\text{V}}{1\mu\text{A}} = 1.18\text{M}$$

$$R2 = R1 \left[ \frac{V_{\text{IN}}}{V_{\text{REF}} + \frac{V_{\text{HB}}}{2}} - 1 \right]$$

$$R2 = 1.18\text{M} \left[ \frac{4.65\text{V}}{1.182\text{V} + \frac{15\text{mV}}{2}} - 1 \right]$$

$$R2 = 3.40\text{M}$$

## TYPICAL APPLICATIONS

10-Bit 30μA A/D Converter

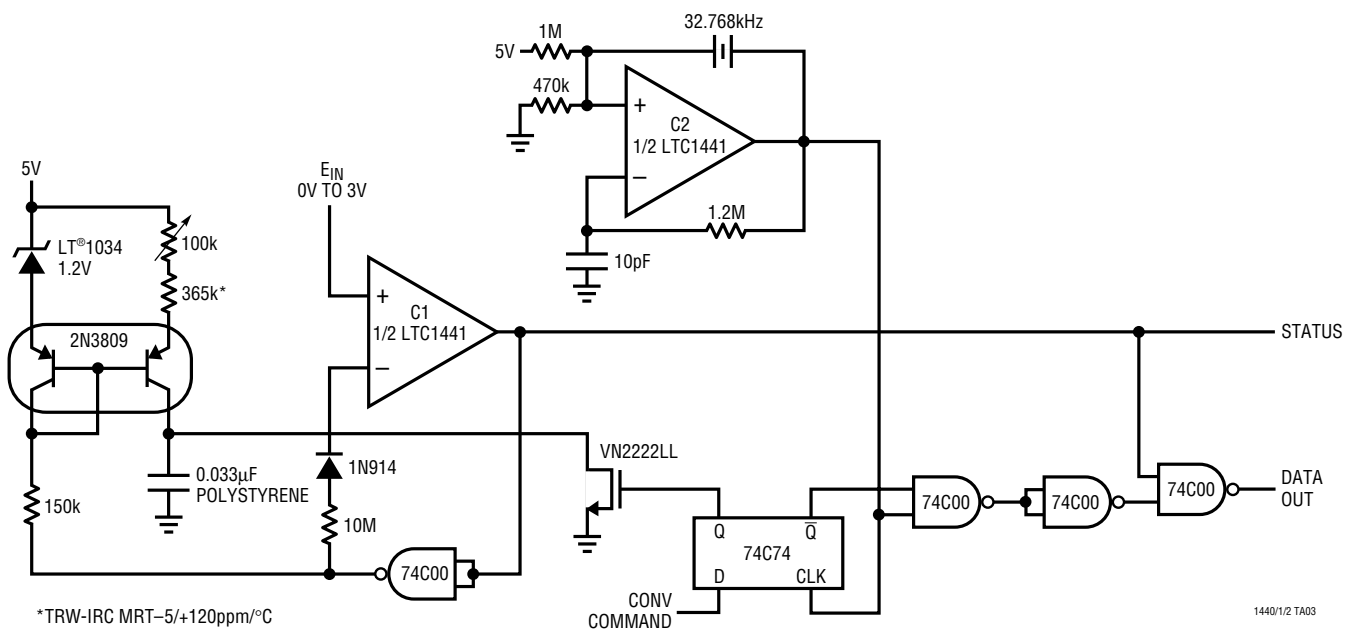

**TYPICAL APPLICATIONS**

**32.768kHz “Watch Crystal” Oscillator**

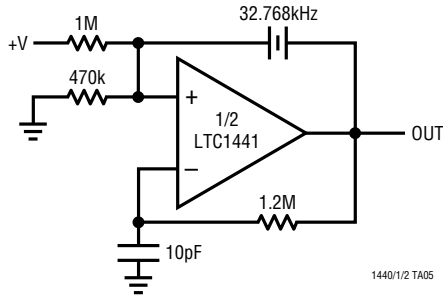

**PACKAGE DESCRIPTION** Dimensions in inches (millimeters) unless otherwise noted.

**N8 Package**  
**8-Lead PDIP (Narrow 0.300)**  
 (LTC DWG # 05-08-1510)

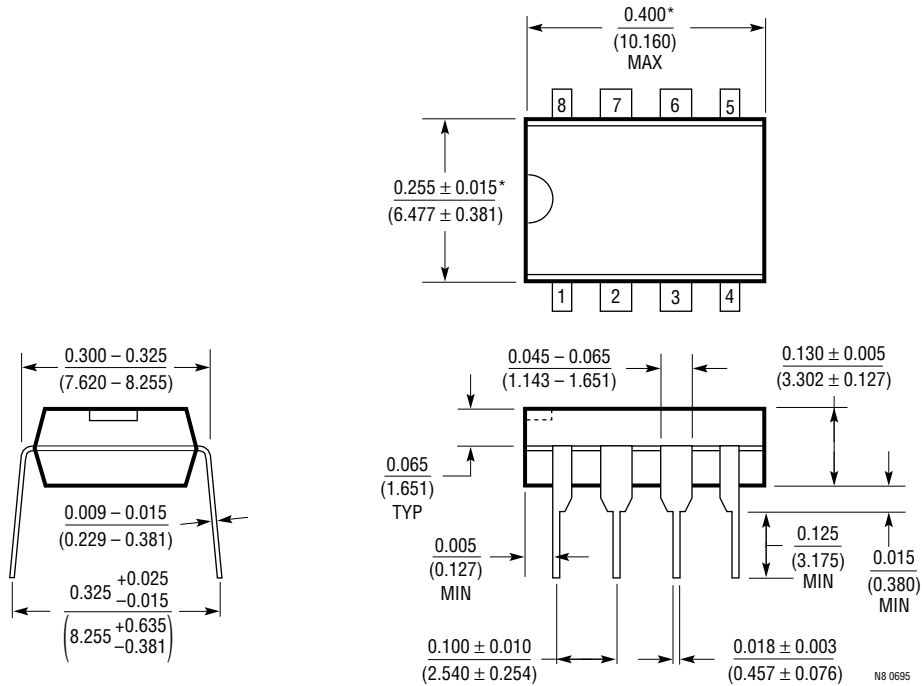

\*THESE DIMENSIONS DO NOT INCLUDE MOLD FLASH OR PROTRUSIONS.  
 MOLD FLASH OR PROTRUSIONS SHALL NOT EXCEED 0.010 INCH (0.254mm)

**PACKAGE DESCRIPTION** Dimensions in inches (millimeters) unless otherwise noted.

**S8 Package**  
**8-Lead Plastic Small Outline (Narrow 0.150)**  
 (LTC DWG # 05-08-1610)

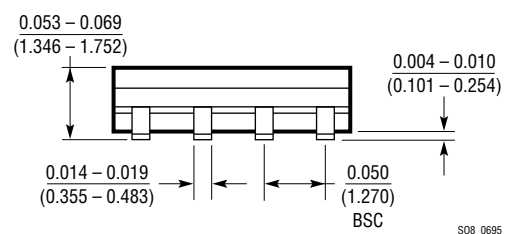
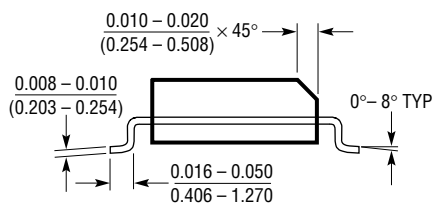
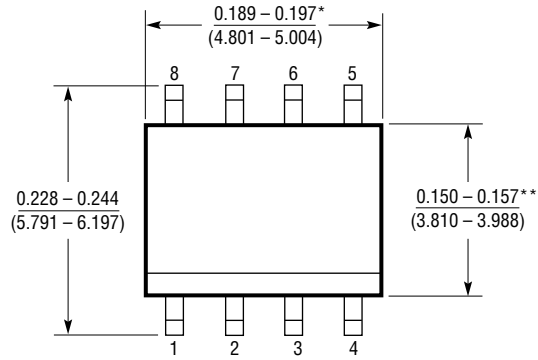

\*DIMENSION DOES NOT INCLUDE MOLD FLASH. MOLD FLASH SHALL NOT EXCEED 0.006" (0.152mm) PER SIDE  
 \*\*DIMENSION DOES NOT INCLUDE INTERLEAD FLASH. INTERLEAD FLASH SHALL NOT EXCEED 0.010" (0.254mm) PER SIDE

