

4

3

2

1

THIS DRAWING IS UNPUBLISHED. VERTRAULICHE UNVERÖFFENTLICHTE ZEICHNUNG		RELEASED FOR PUBLICATION FREI FUER VERÖFFENTLICHUNG		,2000.		MATED WITH: PASSEND ZU: HSK		LOC A1	DIST -	REVISIONS ÄNDERUNGEN				
© COPYRIGHT 1998		BY AMP INCORPORATED.		ALL RIGHTS RESERVED. ALLE RECHTE VORBEHALTEN		PROJEKT NR.: B016898		P	LTR A2	DESCRIPTION BESCHREIBUNG table changed and pachaging added ECR-06-020581		DATE 23.08.06	DWN SR	APVD SM

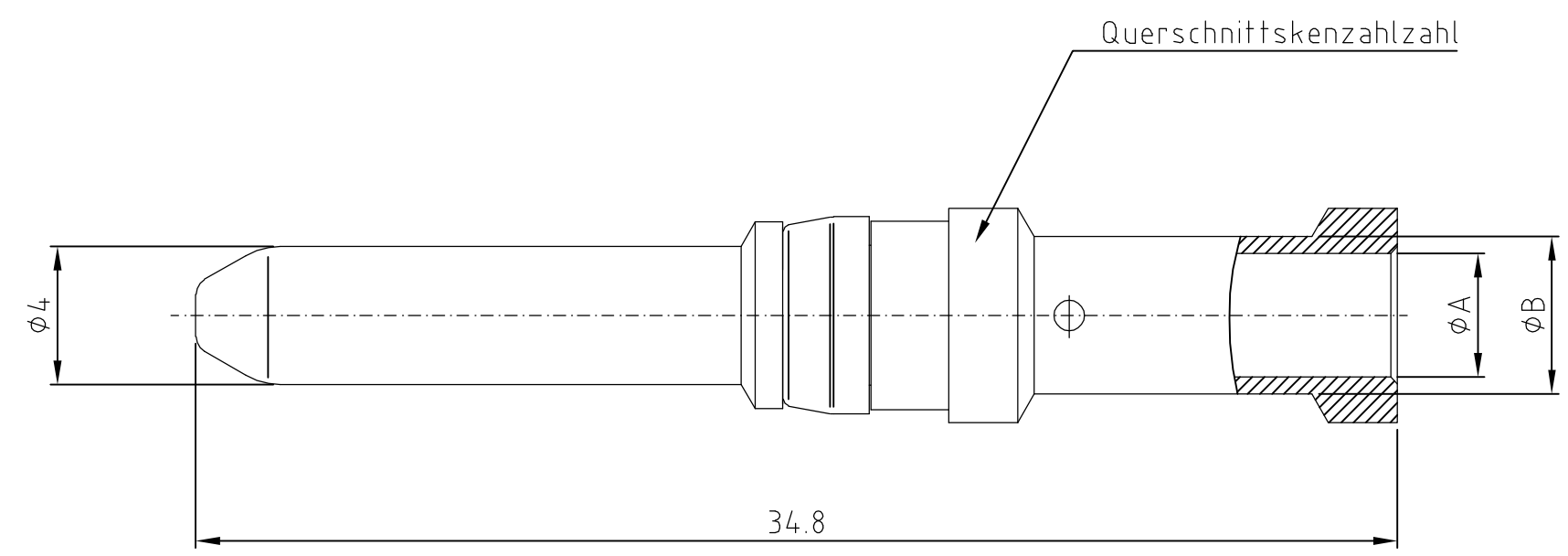

Packaging: 25 pieces

AMP PART NO	BENENNUNG / DESCRIPTION	MATERIAL WERKSTOFF	FINISH OBERFLÄCHE	WIRE - SIZE LEITERQUERSCHNITT	DIA. MAß ØA	DIA. MAß ØB	DESIGNATION KENNZEICHNUNG	STRIPPING LENGTH ABISOLIERLÄNGE (mm)
5-1	HSK-C-Sti.Ag 10 mm ²	MS / BRASS	AG	10 mm ²	4.35	5.9	8	12
4-1	HSK-C-Sti.Ag 6.0 mm ²	MS / BRASS	AG	6.0 mm ²	3.5	4.9	7	12
3-1	HSK-C-Sti.Ag 4.0 mm ²	MS / BRASS	AG	4.0 mm ²	2.85	3.9	6	12
2-1	HSK-C-Sti.Ag 2.5 mm ²	MS / BRASS	AG	2.5 mm ²	2.2	3.2	5	12
1-1	HSK-C-Sti.Ag 1.5 mm ²	MS / BRASS	AG	1.5 mm ²	1.8	3.0	4	12

<small>THIS DRAWING IS A CONTROLLED DOCUMENT FOR AMP INCORPORATED. IT IS SUBJECT TO CHANGE AND THE CONTROLLING ENGINEERING ORGANIZATION SHOULD BE CONTACTED FOR THE LATEST REVISION. DIESES ZEICHNUNGSDOKUMENT WIRD DURCH AMP INCORPORATED KONTROLLIERT. ÄNDERUNGEN, DIE DEM TECHNISCHEN FORTSCHRITT DIENEN, SIND VORBEHALTEN. DEN JEWEILS LETZTIGELTIGEN ÄNDERUNGSSTAND ERFAHREN SIE AUF ANFRAGE.</small>		DWN Schneider 19.06.2000 CHK 19.06.2000 APVD - PRODUCT SPEC PRODUKTSPEZ. - APPLICATION SPEC VERARBEITUNGSSPEZ. - WEIGHT GEWICHT - CUSTOMER DRAWING /KUNDENZEICHNUNG		HTS Elektrotechnik 53819 Neunkirchen, Germany Contact Pin HSK Kontaktstift HSK SIZE A3 CAGE CODE 00779 DRAWING NO ZEICHNUNGS-NR. G- 1108757 RESTRICTED TO NUR FUER - SCALE MASSSTAB 5:1 SHEET BLATT 1 OF VON 1 REV. A2	
DIMENSIONS: DIMENSIONEN: mm 		TOLERANCES UNLESS OTHERWISE SPECIFIED: ALLGEMEINTOLERANZEN n. ISO 8015 n. ISO 2768 - mH - E n. DIN 16901 - 140 0 PLC # 1 PLC # 2 PLC # 3 PLC # ANGLES / WINKEL # FINISH / OBERFLÄCHE / FARBE			