

CUSTOMER _____ Y02 _____

Approval Sheet

DESIGNED NO.: SWITCHING POWER SUPPLIES



MODEL NO.: 3A-181WP15

ENG NO.: @3A-181WP15-026

APPROVAL		

Remark: 1).Please approve and sign back to ENG ELEC.

2).If there is no signing back,this Approval sheet will be regarded as being approved automatically once the first P.O. of the model specified in the sheet is issued.

SUPPLIER		
DESIGN	CHECKED	APPROVED
		



英格爾

英格爾科技股份有限公司
ENG ELECTRIC CO., LTD.

台灣省桃園縣龜山鄉民生北路1段536號5樓

5F,NO.536,Sec.1.Min Sheng N.Rd;Kweishan Hsiang,Taoyuan Hsien,Taiwan,R.O.C.

TEL: 886-3-2121133, 886-3-212199

FAX: 886-3-2121561

深圳英格爾電子有限公司
SHENZHEN ENG ELECTRONICS CO., LTD.

深圳市寶安區福永鎮白石廈中核集團B棟

Block B, Nuclear Group Industrial District, Baishixia, Fuyong Town, Bao'an, Shen Zhen China

TEL: 86-755-27307512,27307515,27308750,27308755,27307208,27308202

FAX: 86-755-27308049

SHENZHEN ENG ELECTRONICS CO., LTD.

FILE NO.: EN-RDS-6226

FILE: @3A-181WP15-026

產品承認書

SHEET: 01

1 Product Characteristics:

1.1 General Description

Model 3A-181WP15 is a universal switching-mode power supply, operating at input voltage 90VAC to 255VAC and output voltage of 15VDC with 1.2A DC load

1.2 Electric Characteristics

1.2.1 Input

No	ITEM	SPECIFICATION
1.	Rated input Voltage	AC100V-240V
	Vibration input Voltage Range	AC90V-255V
2.	Frequency Rated	50-60Hz
	Frequency Vibration	47-63Hz
3.	Input Rated Current	600mA RMS Max
	Inrush Current	30A Max .at 115vac cool start
		60A Max. at 230vac cool start
4.	Standby current	0.25mA

SHENZHEN ENG ELECTRONICS CO., LTD.

FILE NO.: EN-RDS-6226

FILE: @3A-181WP15-026

產品承認書 SHEET: 02

1.2.2 Output:

No	ITEM	V1
1.	output Voltage	15VDC
2.	output max. current	1.2A
3.	output min. Current	0A
4.	Line regulation	$\pm 1\%$
5.	Load regulation	$\pm 5\%$
6.	Over voltage protection	17.1 to 18.9V DC(output shut down)
7.	Short circuit protection	Output shut down and auto restart
8.	Ripple Voltage (L.F.)	150mV (p-p) (100V-240VAC Input)

1.2.3 HI-POT SPECIFICATION

Input to output : 3000VAC or 4242VDC 10mA 1 minute.

1.2.4 Insulation resistance:

Input to output: 500vdc to test the input to output resistance not be less 100M ohm

1.2.5 Safety approved: TUV CE UL CUL

SHENZHEN ENG ELECTRONICS CO., LTD.

FILE NO.: EN-RDS-6226

FILE: @3A-181WP15-026

產品承認書 SHEET: 03

1.3 Mechanical Characteristics

1.3.1 AC Plug : Interchangeable PIN(VDE BS SAA UL)

1.3.2 DC cord:

(1) Bending test: Life 1000 times 100% guarantee. Swings 120 from

Left to right loading weight 500g , 40 cycle/minute.

(2) Pull test : DC cord and plug ,weight 6kg for 1 minute.

1.3.3 Cord length and output plug: See Reference Att.4

1.3.4 Weight : _____g

1.3.5 Case Size: (L)74 X (W) 43.5X (H) 34mm

1.3.6 Normal operating temperature and humidity

1.3.7 Temperature

Operating: 0°C to 40°C

Storage : -10°C to 70°C

1.3.8 Humidity

Operating : 20% to 80%.

Storage: 10% to 90%

SHENZHEN ENG ELECTRONICS CO., LTD.

FILE NO.: EN-RDS-6226

FILE: @3A-181WP15-026

產品承認書 SHEET: 04

2.Attachment:

- (Att.1) Label
- (Att.2) Outdrawing
- (Att.3) Package
- (Att.3.1) Package flow chart
- (Att.4) Dc cord drawing
- (Att.5) Material test report
- (Att.6) Electrical test report

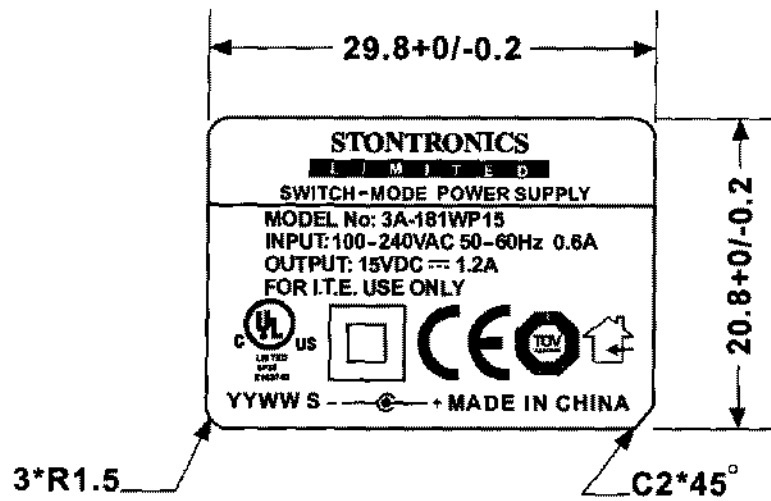

UNIT: mm

YYWW S YY:YEAR WW:WEEK S:FU YONG

ALUMINUM NAMEPLATE: ○ BLACK WORD ON SILVER BASE

○ SILVER WORD ON BLACK BASE

METALIZED POLYESTER: ● BLACK WORD ON SILVER BASE

(SILVER MATTE)

○ SILVER WORD ON BLACK BASE

				TOLERANCE			
@3A-181WP15-026							
DESIGNED	CHECKED	APPROVED		TITLE			DATE
<i>Lipp</i>				LABEL			
			UNITS	mm	DRAWING No.		
			SCALE	2:1	N0Y02-0062		05/01/17
ENG ELECTRICS CO., LTD.				DRAWING NAME			REVISION
				1007			01

Att.2

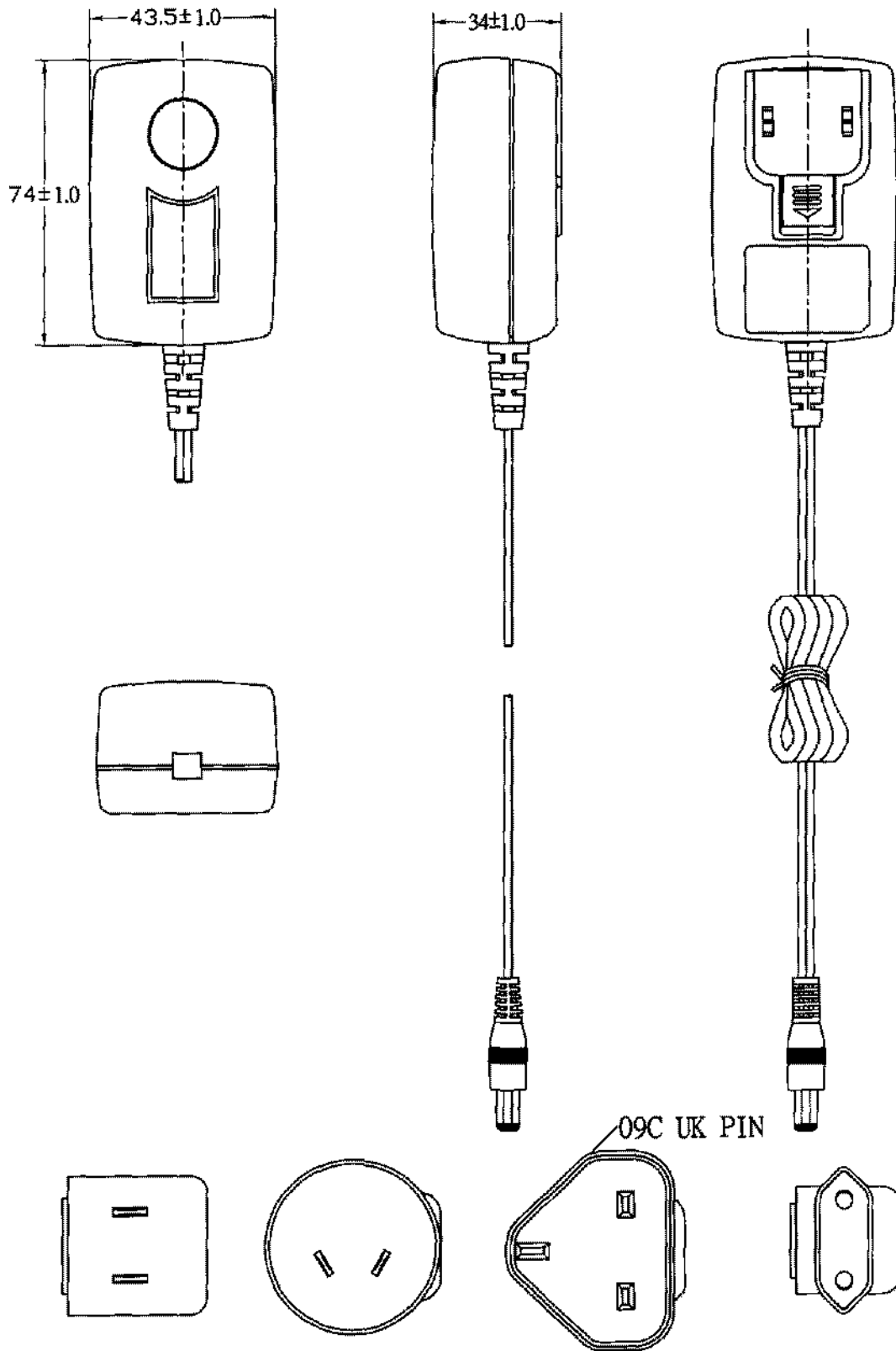

09C UK PIN

TOLERANCE				

DESIGNED	CHECKED	APPROVED	UNITS		TITLE	DATE
<i>Lipin</i>			mm		OUTDRAWING	05/01/17
ENG ELECTRIC CO; LTD					DRAWING No. @3A-181WP15-026	REVISION 01
					DRAWING NAME 100721	

Att.3

CARTON SIZE: 478X421X200mm

外箱尺寸 478X421X200mm

Q'TY: 60pcs(20x3)

数量 60pcs(20x3)

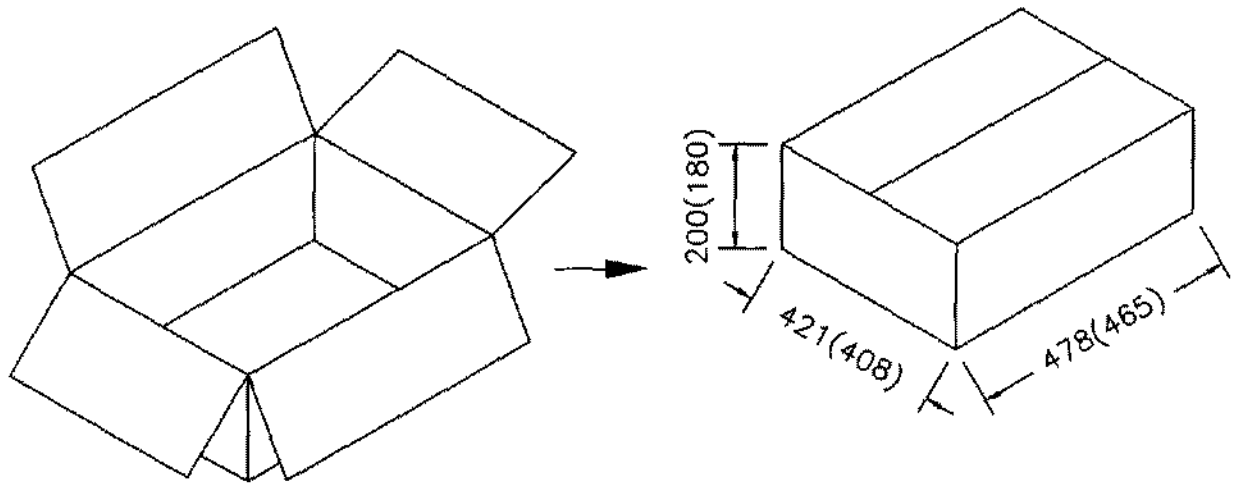
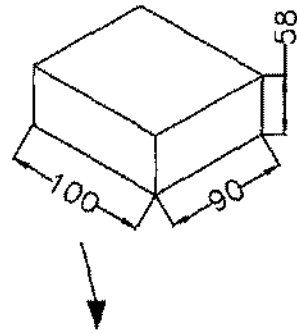

The tolerance of the internal dimensions of the carton is +7/-0

纸箱内度尺寸公差为+7/-0

TOLERANCE				

DESIGNED	CHECKED	APPROVED		TITLE	PACKAGE	DATE
<i>Lipin</i>				UNITS	mm	DRAWING No.
ENG ELECTRIC CO; LTD				SCALE	P13-2030-H-50	REVISION
					13-2030-H-50	01

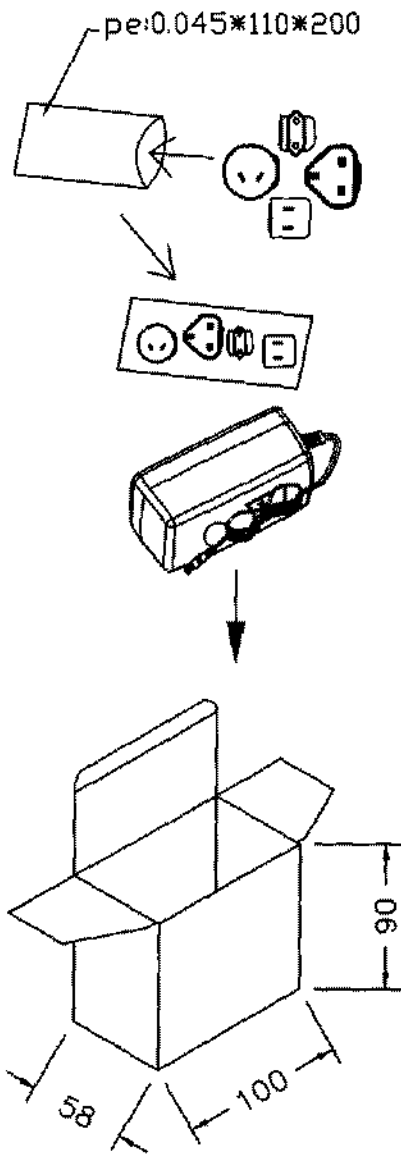



White Box: NO.13

小礼盒号码 13#

The tolerance of the external dimensions of the white box is ± 1
 小礼盒外度尺寸公差为 ± 1

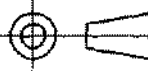
TOLERANCE				

DESIGNED	CHECKED	APPROVED	 UNITS mm SCALE	TITLE PACKAGE FLOW CHART	DATE
Lipp				DRAWING No. @3A-181WP15-026	05/01/17
ENG ELECTRIC CO; LTD				DRAWING NAME 13#	REVISION 01

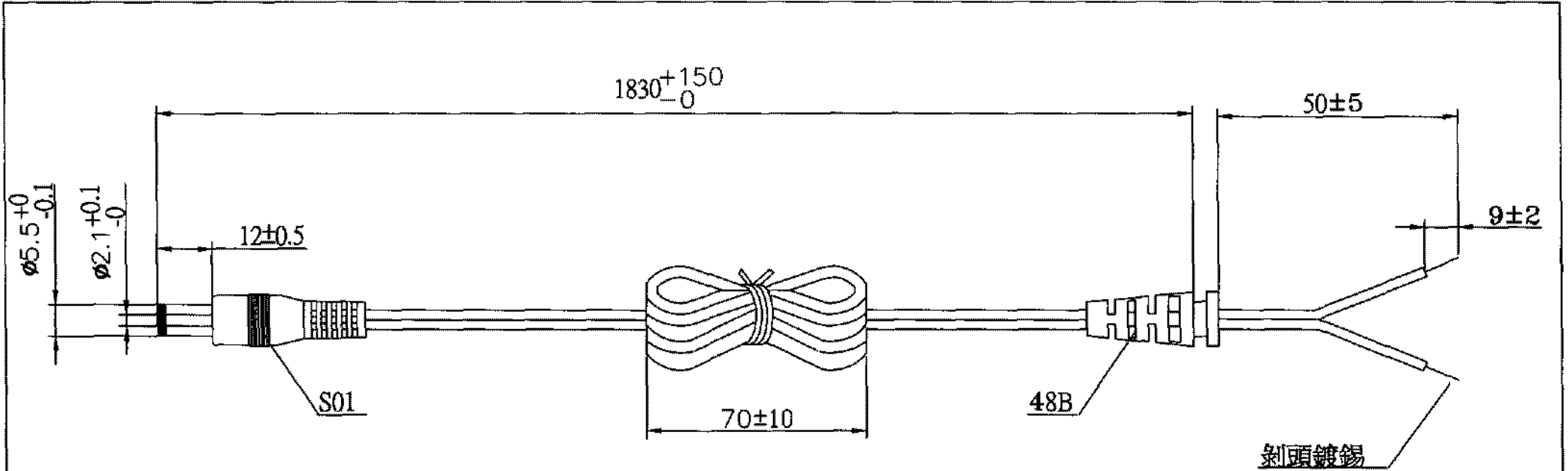

#20AWG X2C UL2468

有字接外 無字接內

線材OD: Ø1.9*3.8



TOLERANCE				

制作參數要求	
搖擺測試 VIBRATION TEST	a. ±60° b. 吊重200g WEIGHT 200g c. 40回/分 40 ROUND/MINUTE d. 1000次/最少 OVER 1000 COUNT MIN

DESIGNED	CHECKED	APPROVED	UNITS		TITLE
Lip			mm	mm	DC CORD
ENG ELECTRIC CO; LTD					DRAWING No. @3A-181WP15-026
					DRAWING NAME 31-48BS01-03B-00

DATE	REVISION
05/01/17	01