

15 SERIES MOULDED CASE CURRENT TRANSFORMERS

HOBUT

DESCRIPTION

Two small moulded case current transformers suitable for primary currents from 1A to 500A using cable or bar primaries

APPLICATION

For use where space is limited within the panel, and where a built in choice of fixing methods is required.

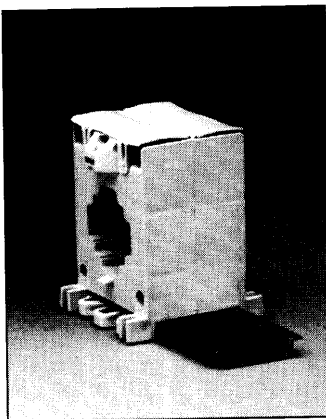
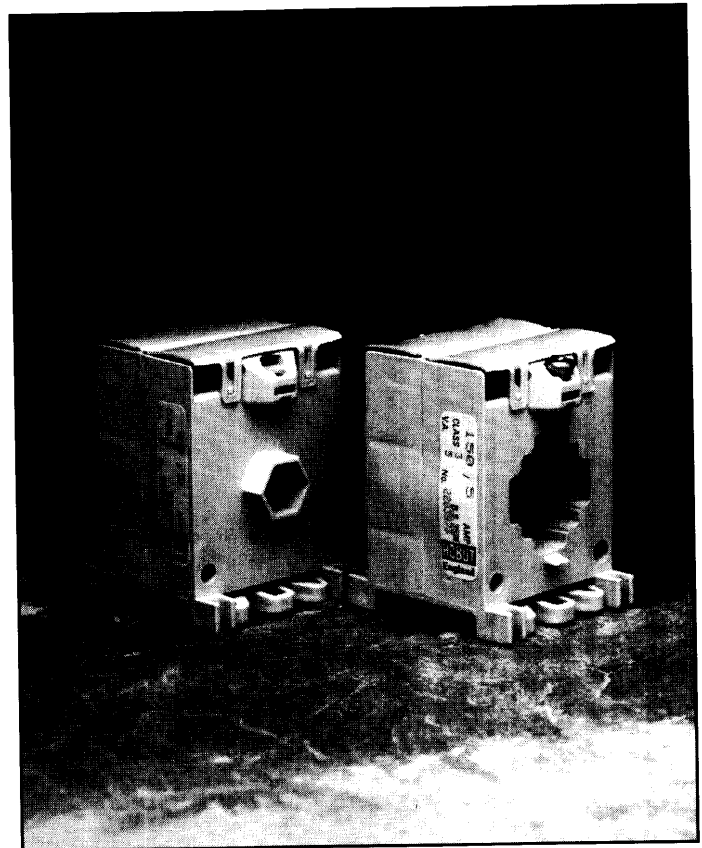

DIN rail mounting

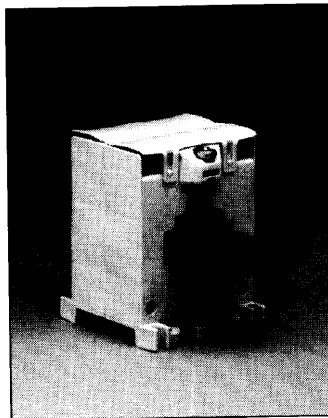

Busbar mounting

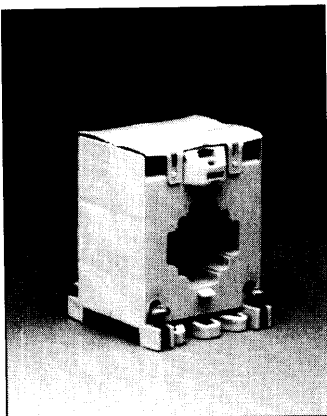

Base mounting

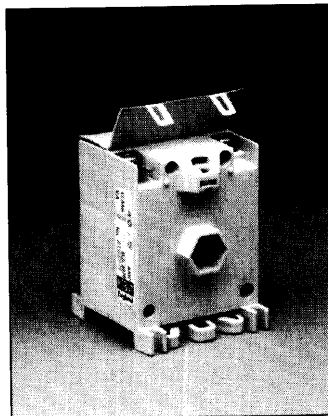

Hinged terminal cover

FEATURES

- Three built in fixing methods
 - Base, Din Rail & Busbar mounting
- Built in hinged terminal cover
- Terminals suitable for screw or push on connectors
- Small size enables mounting where busbars run close together
- Case moulded in high impact polyester
- Secondary terminals with double layout
- Primary ranges from 1A to 500A

TECHNICAL OVERVIEW

- Conforms to IEC 44-1 / IEC 185, BS 7626
- Insulation level 0.72/3kV
- Ambient temperature range -20° to 70°C
- Enclosure to IP20
- CE approved
- Manufactured to ISO 9002

15 SERIES MOULDED CASE CURRENT TRANSFORMERS

HOBUT

TYPE 151

Type: 151-5 5A Secondary
151-1 1A Secondary

VA Primary	CLASS 3					CLASS 1					CLASS 0.5			
	2.5	5	7.5	10	15	2.5	5	7.5	10	15	2.5	5	7.5	10
1	A1	A2	-	A4	-	A6	A7	-	-	-	-	-	-	-
2.5	B1	B2	-	B4	-	B6	B7	-	-	-	-	-	-	-
5	C1	C2	-	C4	-	C6	C7	-	-	-	-	-	-	-
7.5	D1	D2	-	D4	-	D6	D7	-	-	-	-	-	-	-
8	E1	E2	-	E4	-	E6	E7	-	-	-	-	-	-	-
10	F1	F2	-	F4	-	F6	F7	-	-	-	-	-	-	-
15	G1	G2	-	G4	-	G6	G7	-	-	-	-	-	-	-
20	H1	H2	-	H4	-	H6	H7	-	-	-	-	-	-	-
25	J1	J2	-	J4	-	J6	J7	-	-	-	-	-	-	-
30	K1	K2	-	K4	-	K6	K7	-	-	-	-	-	-	-
40	L1	L2	-	L4	-	L6	L7	-	-	-	-	-	-	-
50	M1	M2	-	-	-	M6	-	-	-	-	-	-	-	-
60	N1	N2	-	N4	-	N6	-	-	-	-	-	-	-	-
75	P1	P2	-	P4	-	P6	-	-	-	-	-	-	-	-
80	R1	R2	-	R4	-	R6	-	-	-	-	-	-	-	-
100	S1	S2	-	S4	-	S6	S7	-	-	-	S11	-	-	-

Denotes double wound / wound primary

SUITABLE FOR:

Cables up to 14mm outside diameter, or a conducting bush 14mm wide.

ORDER EXAMPLE:

A 50/5A 2.5VA class 1 current transformer is product code 151-5-M6.

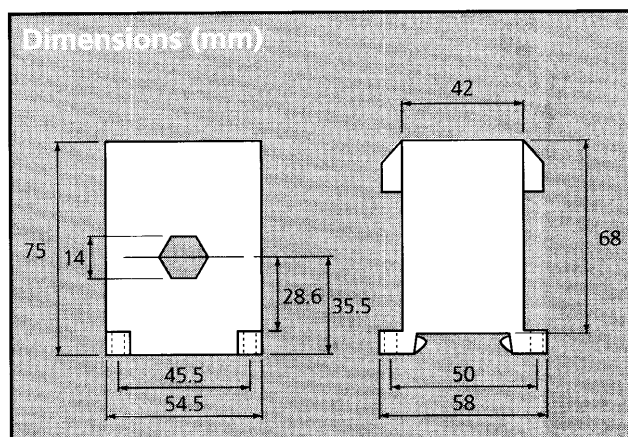

TYPE 153

Type: 153-5 5A Secondary
153-1 1A Secondary

VA Primary	CLASS 3					CLASS 1					CLASS 0.5			
	2.5	5	7.5	10	15	2.5	5	7.5	10	15	2.5	5	7.5	10
75	P1	-	-	-	-	-	-	-	-	-	-	-	-	-
80	R1	-	-	-	-	-	-	-	-	-	-	-	-	-
100	S1	-	-	-	-	S6	-	-	-	-	-	-	-	-
150	T1	T2	-	-	-	T6	T7	-	-	-	T11	-	-	-
200	V1	V2	-	-	-	V6	V7	-	-	-	V11	V12	-	-
250	W1	W2	-	-	-	W6	W7	-	-	-	W11	W12	-	-
300	X1	X2	X3	-	-	X6	X7	-	-	-	X11	X12	-	-
400	Y1	Y2	-	Y4	-	Y6	Y7	Y8	-	-	Y11	Y12	Y13	Y14
500	Z1	Z2	-	Z4	-	Z6	Z7	-	Z9	-	Z11	Z12	Z13	Z14

SUITABLE FOR:

Cables up to 26mm outside diameter, bars up to 30mm wide or a conducting bush 24mm wide.

ORDER EXAMPLE:

A 200/1A 5VA class 3 current transformer is product code 153-1-V2.

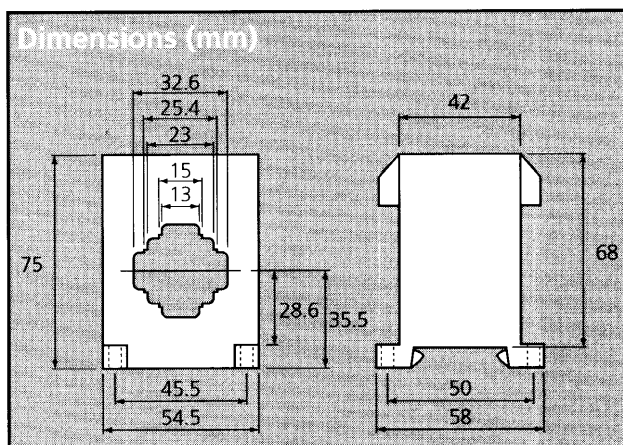

STANDARD ACCESSORIES

- Type 151 and 153 are supplied with 4off M4 x 10 pan head with lock washers plus 2off 6.3 x 0.8 push on blades.
- Type 153 is supplied with 2off M4 x 40 pan head pozidrive screws
- Other fixing accessories available on request.

Our policy is one of continuous development and therefore specifications may change without notice.

HOWARD BUTLER LTD

CROWN WORKS, LINCOLN ROAD
WALSALL WS1 2EB ENGLAND

Tel: 01922 640003 Fax: 01922 723626
International: +44 1922 640003