

10 Watts

AEE00-12Vin

Total Power: 10 Watts
Input Voltages: 12V
No. of Outputs: Single and Dual



Special Features

- 10 W, Dual output
- 2:1 Input range
- 1.0" x 2.0" x 0.33 case
- Industry standard package
- Low Profile
- Low Cost

Environmental

Operating base temperature range:
-25°C to +100°C
Storage temperature: -40°C to +125°C
MTBF: 3 Million Hours (Belcore TR332)

Safety

UL UL1950 Recognition
CSA CSA22.2-950 Recognition
TUV EN60950 Recognition

Electrical Specs

Input

Input range 9 to 18 VDC
Efficiency 78% typical (3.3V)

Output

Voltage tolerance $\pm 1.0\%$
Overall regulation $\pm 1\%$ max
Noise/ripple 1% Typ, 2% Max
Transient response 300 usec typical (50% step load change to within 3%Vo)

Temperature Regulation $\pm 0.02\% \text{Vo}/^\circ\text{C}$

Switching frequency 330kHz

Isolation

I/O isolation 1500 VDC Input to Output
1000 VDC Input to Case
1000 VDC Output to Case

Isolation Resistance 300 Mohms

AMERICAS

5810 Van Allen Way
 Carlsbad, CA 92008
 Telephone: 760-930-4600
 Facsimile: 760-930-0698

EUROPE

Astec House, Waterfront Business Park
 Merry Hill, Dudley
 West Midlands, DY5 1LX, UK
 Telephone: 44 (1384) 842-211
 Facsimile: 44 (1384) 843-355

ASIA

Units 2111-2116, Level 21
 Tower1, Metroplaza
 223, Hing Fong Road
 Fwai Fong, New Territories
 Hong Kong
 Telephone: 852-2437-9662
 Facsimile: 852-2402-4426



Ordering Information

Input Voltage	Output Voltage	Efficiency	Model Number
9-18 V	3.3V @ 2.55 A	78%	AEE02F12-49
9-18 V	5.0V @ 2 A	81%	AEE02A12-49
9-18 V	12V @ 0.84 A	83%	AEE00B12-49
9-18 V	15V @ 0.68 A	84%	AEE00C12-49
9-18 V	±5V @ ±1.0 A	81%	AEE01AA12-4
9-18 V	±12V @ ±0.42 A	83%	AEE00BB12-4
9-18 V	±15V @ ±0.33 A	84%	AEE00CC12-4

NOTES:

Enable Function

1. With the control pin floating (*no connection*), the unit is enabled and there is an output of 5V.
2. With the control pin Low (short to -Vin), the unit is enabled and there is an output of 5V.
3. With the control pin connected to an external logic signal (5V), the unit is disabled and there is no output.

Trim Feature

"9" at end of Model Number designates Trim option.

Mechanical Dimensions and Pin Assignments

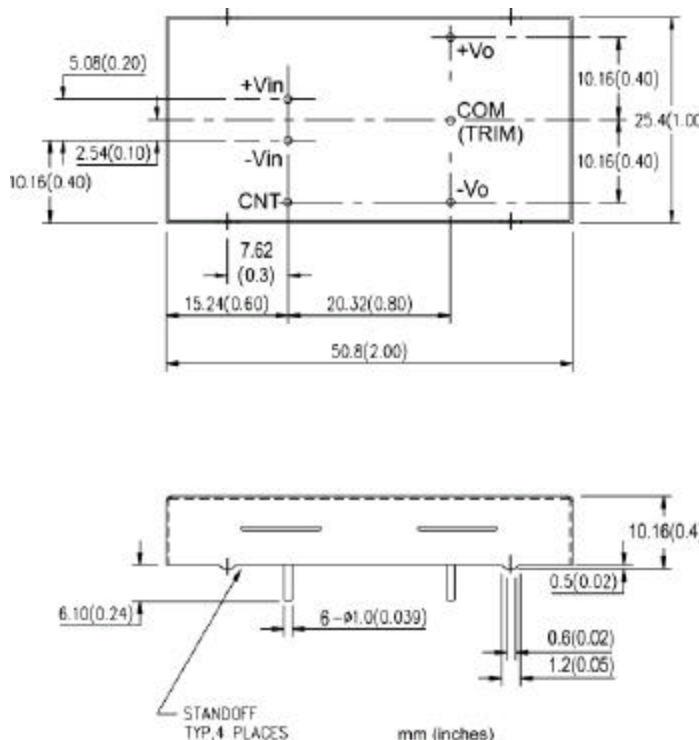

Notes:

1. 20 MHz bandwidth. An external 0.1 uf ceramic capacitor is recommended to be placed from +V out to comm.
2. All specifications are typical at nominal line, full load, and 25°C unless otherwise noted.
3. All specifications subject to change without notice.
4. Mechanical drawings are for reference only.

AEE-10W 12V Input Series

Technical Reference Notes

$\pm 5V$, $\pm 12V$, $\pm 15V$ Dual Output

10 Watt DC-DC Converter



USA
TEL: 1-760-930-4600
FAX: 1-760-930-0698

Europe
44-(0)1384-842-211
44-(0)1384-843-355

Asia
852-2437-9662
852-2402-4426 www.astec.com

Introduction

The AEE-10W 12V input dual output series of switching DC-DC converters is one of the most cost effective options available in component power. The series uses an industry standard 1" X 2" package and pinout configuration, with CNT function available.

AEE-10W 12V input dual output series uses a 2:1 input range of 9V to 18V, outputs are isolated from input and the converters are capable of providing up to 10 watts of output power.

At start up, input current passes through an input filter designed to help meet CISPR 22 level A radiated emissions, and Bellcore GR1089 conducted emissions. A fault clearing device such as a fuse should be used in line with the input to the module.

The AEE-10W 12V input dual output converters are pulse width modulated (PWM) and operate at a nominal fixed frequency of 330 kHz. Feedback to the PWM controller uses an opto-isolator, maintaining complete isolation between primary and secondary. Caution should be taken to avoid ground loops when connecting the converters to ground.

Design Features

- ☞ 2" X 1" package
- ☞ High efficiency
- ☞ High power density
- ☞ 10 watts of output power
- ☞ 2:1 wide input of 9-18V
- ☞ Remote ON/OFF function
- ☞ Input under-voltage lockout
- ☞ Output short circuit protection
- ☞ Output current limiting
- ☞ High input-output isolation voltage
- ☞ Wide operating case temperature range:
-25°C~ +100°C

Typical Application

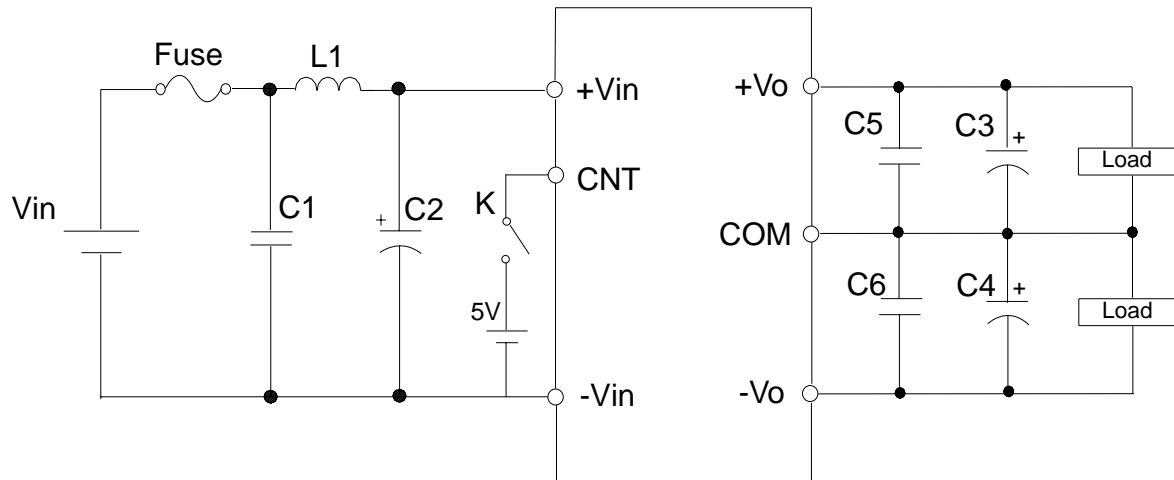

Note: The figure is Negative Control, and reverse Positive Control is available.

K connects, output OFF.

K disconnects or CNT is in midair, output ON.

L1:Recommended:

10--12uH

Fuse: 12Vin--4A

C1 Recommended:

12Vin--220uF/25V electrolytic or ceramic type capacitor

C2 Recommended:

≥ 47uF/25V capacitor

C3, C4 Recommended:

100uF/25V electrolytic or ceramic type capacitor

C5, C6 Recommended:

0.47uF capacitor

**AEE-10W 12V Input Series DC-DC Converters
±5V, ±12V, ±15V 10 Watt Dual Output**

Block Diagram

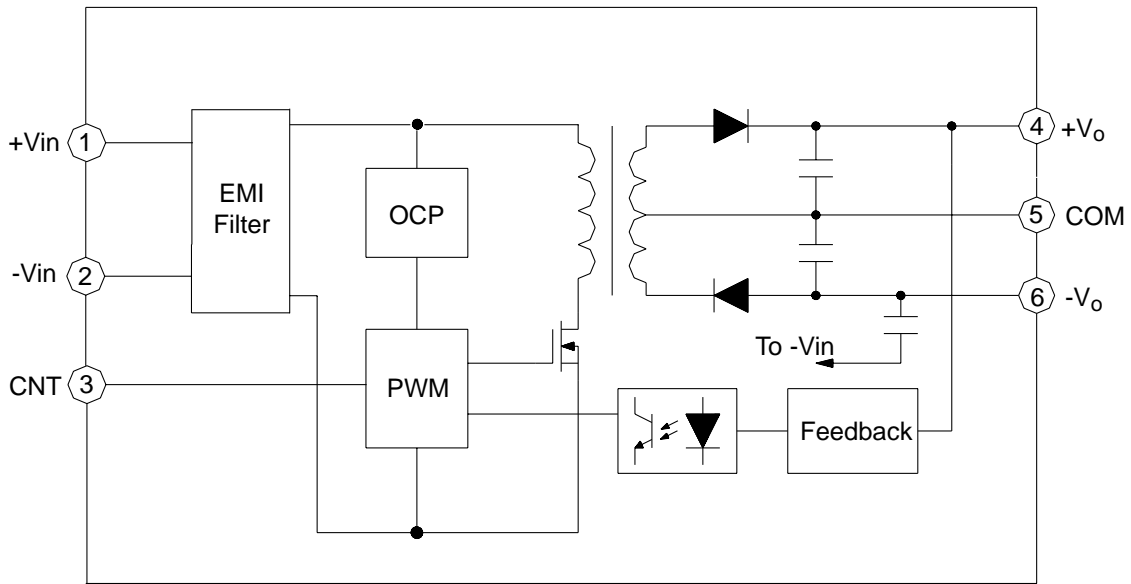

Ordering Information

Model Number	Input Voltage	Output Voltage	Output Current	Ripple (mV rms) typ	Noise (mV pp) typ	Efficiency typ
AEE01AA12	9-18V	±5V	±1A	10	60	81%
AEE01BB12	9-18V	±12V	±0.42A	10	90	84%
AEE01CC12	9-18V	±15V	±0.34A	10	90	85%

AEE-10W 12V Input Series DC-DC Converters
±5V, ±12V, ±15V 10 Watt Dual Output

Absolute Maximum Rating

Characteristic	Min	Typ	Max	Units	Notes
Input Voltage(continuous)	-0.3		200	Vdc	50ms non-repetitive
Input Voltage(peak/surge)	-0.3		50	Vdc	
Case temperature	-25		100	°C	
storage temperature	-40		125	°C	

Input Characteristics

Characteristic	Min	Typ	Max	Units	Notes
Input Voltage Range	9	12	18	Vdc	
Input Reflected Current			10	%lin	
Turn-off Input Voltage			7.6	Vdc	
Turn-on Input Voltage	8.4			Vdc	
Turn On Time				ms	

Control Function

Characteristic	Min	Typ	Max	Units	Notes
Logic High	3.6		6	Vdc	Reverse logic option "P" available
Logic Low	0		0.7	Vdc	
Control Current				mA	

General Specifications

Characteristic	Min	Typ	Max	Units	Notes
MTBF		3,000		k Hrs	Bellcore TR332, Tc=30°C
Isolation			1500	Vdc	
Pin solder temperature			260	°C	wave solder < 10 s
Hand Soldering Time			5	s	iron temperature 425°C
Weight		25		grams	

AEE-10W 12V Input Series DC-DC Converters
±5V, ±12V, ±15V 10 Watt Dual Output

AEE01AA12 Output Characteristics

Characteristic	Min	Typ	Max	Units	Notes
Power		10		W	
Output Current		±1		A	
Output Setpoint Voltage	4.95	5	5.05	Vdc	Vin=12V, Io=±1A
Line Regulation			0.2	%Vo	Vin=9~18V, Io=±1A
Load Regulation			0.5	%Vo	Io=0~±1A, Vin=12V
Dynamic Response					
50-75% load			100	%Vo	Ta=25°C, DI/Dt=1A/10µs
			200	µs	Ta=25°C, DI/Dt=1A/10µs
50-25% load			100	%Vo	Ta=25°C, DI/Dt=1A/10µs
			200	µs	Ta=25°C, DI/Dt=1A/10µs
Current Limit Threshold				A	
Short Circuit Current				A	
Efficiency	79	81		%	Vin=12V, Io=±1A, Ta=25°C
Trim Range	90		110	%Vo	
Over Voltage Protection Setpoint				V	
Temperature Regulation			0.04	%Vo/°C	
Ripple (rms)		10		mV	(0 to 20MHz Bandwidth)
Noise (p-p)		30		mV	(0 to 20MHz Bandwidth)
Switching Frequency		330		kHz	

AEE-10W 12V Input Series DC-DC Converters
±5V, ±12V, ±15V 10 Watt Dual Output

AEE01BB12 Output Characteristics

Characteristic	Min	Typ	Max	Units	Notes
Power		10		W	
Output Current		±0.42		A	
Output Setpoint Voltage	±11.88	±12	±12.12	Vdc	Vin=12V, Io=±0.42A
Line Regulation			0.2	%Vo	Vin=9~18V, Io=±0.42A
Load Regulation			0.5	%Vo	Io=0~±0.42A, Vin=12V
Dynamic Response					
50-75% load			100	mV	Ta=25°C, DI/Dt=1A/10µs
			200	µs	Ta=25°C, DI/Dt=1A/10µs
50-25% load			100	mV	Ta=25°C, DI/Dt=1A/10µs
			200	µs	Ta=25°C, DI/Dt=1A/10µs
Current Limit Threshold				A	
Short Circuit Current				A	
Efficiency	82	84		%	Vin=12V, Io=±0.42A, Ta=25°C
Trim Range	90		110	%Vo	
Over Voltage Protection Setpoint				V	
Temperature Regulation			0.02	%Vo/°C	
Ripple (rms)		10		mV	(0 to 20MHz Bandwidth)
Noise (pp)		30		mV	(0 to 20MHz Bandwidth)
Switching Frequency		330		kHz	

AEE-10W 12V Input Series DC-DC Converters
±5V, ±12V, ±15V 10 Watt Dual Output

AEE01CC12 Output Characteristics

Characteristic	Min	Typ	Max	Units	Notes
Power		10		W	
Output Current		0.68		A	
Output Setpoint Voltage	14.85	15	15.15	Vdc	Vin=15V, Io=±0.34A
Line Regulation			0.2	%Vo	Vin=9~18V, Io=±0.34A
Load Regulation			0.5	%Vo	Io=0~±0.34A, Vin=12V
Dynamic Response					
50-75% load			100	mV	Ta=25°C, DI/Dt=1A/10µs
			200	µs	Ta=25°C, DI/Dt=1A/10µs
50-25% load			100	mV	Ta=25°C, DI/Dt=1A/10µs
			200	µs	Ta=25°C, DI/Dt=1A/10µs
Current Limit Threshold				A	
Short Circuit Current				A	
Efficiency	83	85		%	Vin=12V, Io=±0.34A, Ta=25°C
Trim Range	90		110	%Vo	
Over Voltage Protection Setpoint				V	
Temperature Regulation			0.02	%Vo/°C	
Ripple (rms)		10		mV	(0 to 20MHz Bandwidth)
Noise (pp)		30		mV	(0 to 20MHz Bandwidth)
Switching Frequency		330		kHz	

Characteristic Curves (at 25 °C)

Typical Efficiency Curves
AEE-10W 12V Input Dual Output Series

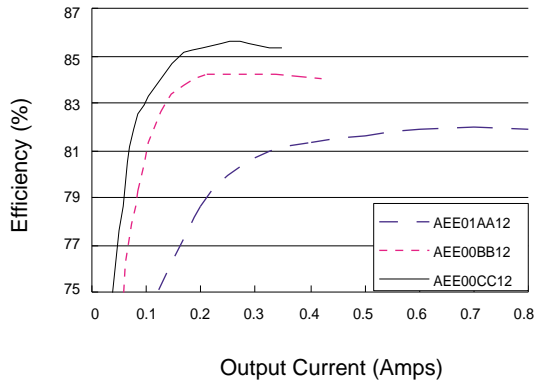

Typical Input-Output Curves
AEE-10W 12V Input Dual Output Series

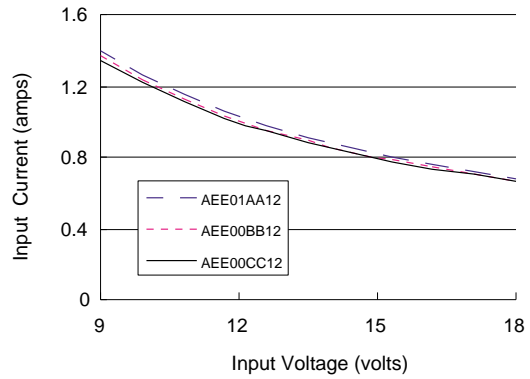

Typical Overcurrent Protection
AEE-10W 12V Input Dual Output Series

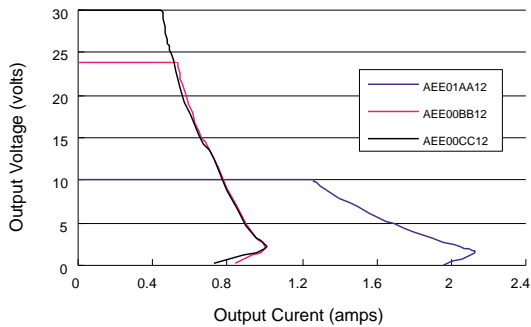

Cross Regulation Curves
AEE01AA12

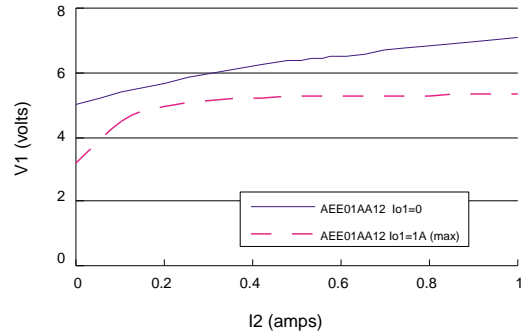

Cross Regulation Curves
AEE01BB12

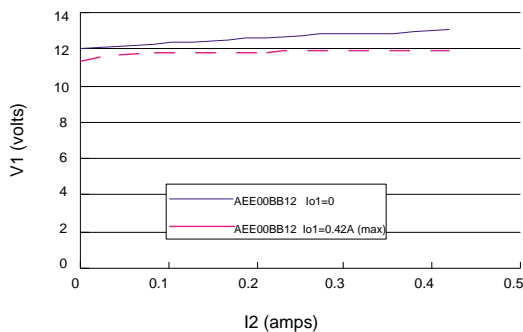

Cross Regulation Curves
AEE01CC12

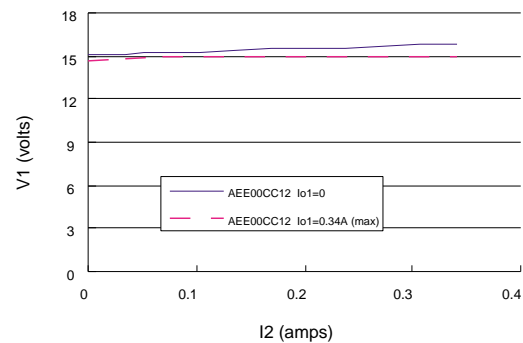

Transient response (rated input voltage, step load, at 25 °C)

Typical Transient Response to Step Load
 Change from 25%-50%I_{omax}
 AEE01AA12

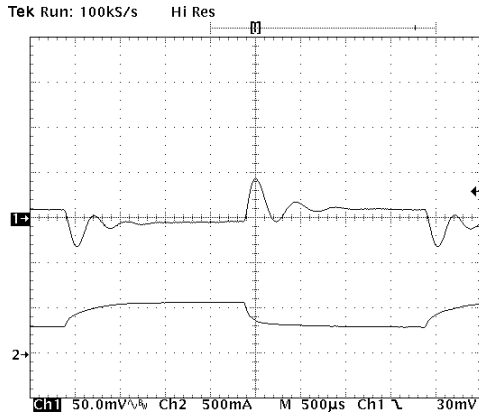

Typical Transient Response to Step Load
 Change from 75%-50%I_{omax}
 AEE01AA12

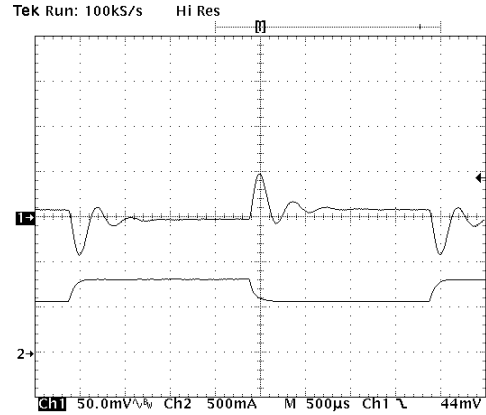

Typical Start-Up from Power On
 AEE01AA12

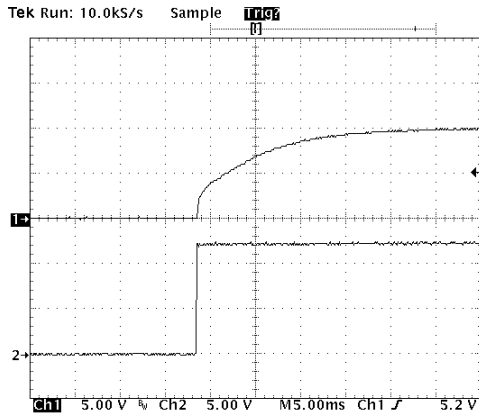

Typical Shut-down from Power Off
 AEE01AA12

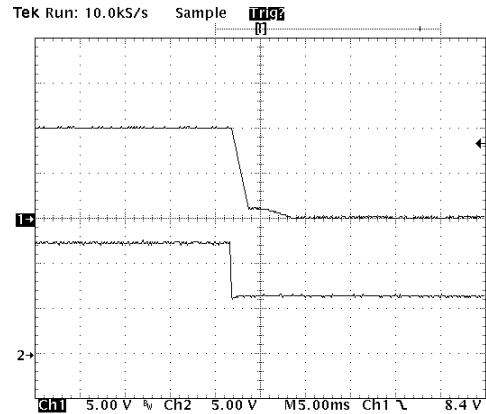

Typical Start-up from Remote On/Off
 AEE01AA12

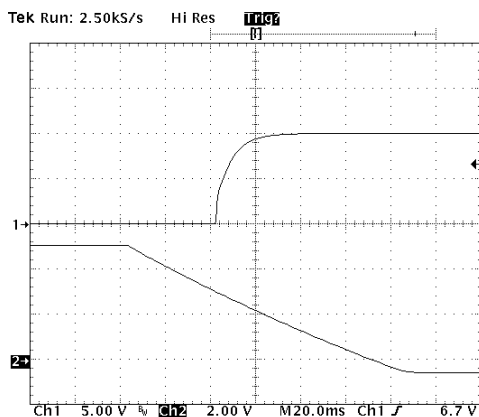

Typical Shut-down from Remote On/Off
 AEE01AA12

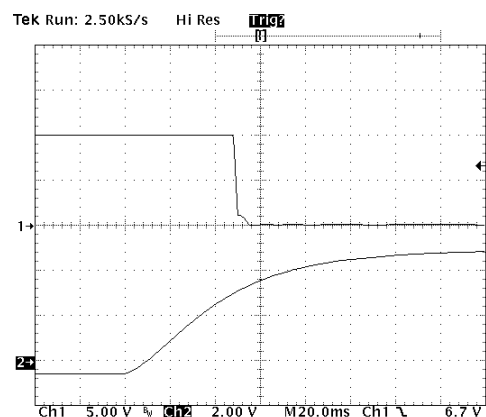

Pin Location

The +Vin and -Vin input connection pins are located as shown in Figure 1. AEE-10W 12V input dual output converters have a 2:1 input voltage range of 9-18V.

Care should be taken to avoid applying reverse polarity to the input which can damage the converter.

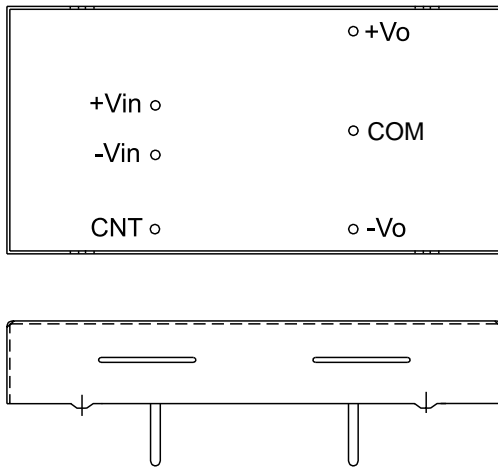

Fig.1 Pin Location

Input Characteristic

Fusing:

The AEE-10W 12V input dual output power module has no internal fuse. An external fuse must always be employed!

To meet international safety requirements, a 250 Volt rated fuse should be used. If one of the input lines is connected to chassis ground, then the fuse must be placed in the other input line. Standard safety agency regulations require input fusing. Recommended fuse ratings for the AEE-10W 12Vin dual output is shown in Table1.

Table 1

Series	Fuse Rating
12Vin	4A

Input Reverse Voltage Protection

Under installation and cabling conditions where reverse polarity across the input may occur, reverse polarity protection is recommended. Protection can easily be provided as shown in Figure 2. In both cases the diode rating is determined by the power of the converter. Diodes should be rated at 4A/25V for the AEE-10W 12V input dual output series.

Placing the diode across the inputs rather than in-line with the input offers an advantage in that the diode only conducts in a reverse polarity condition, which increases circuit efficiency and thermal performance.

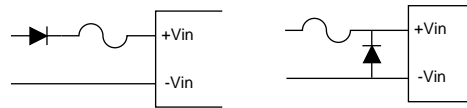

Fig.2 Reverse Polarity Protection Circuits

Input Filter

Input filters are included in the converters to help achieve standard system emissions certifications. Some users however, may find that additional input filtering is necessary. The AEE-10W series has an internal switching frequency

of 330 kHz so a high frequency capacitor mounted close to the input terminals produces the best results. To reduce reflected noise, a capacitor can be added across the input as shown in Figure 3, forming a π filter. A $47\mu\text{F}/25\text{V}$ electrolytic capacitor is recommended for C1.

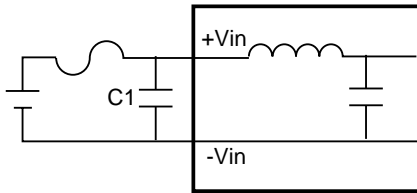

Fig.3 Ripple Rejection Input Filter

For conditions where EMI is a concern, a different input filter can be used. Figure 4 shows an input filter designed to reduce EMI effects. L1 is a $12\mu\text{H}$ differential inductor, C1 is a $47\mu\text{F}/25\text{V}$ electrolytic capacitor, and C0 is a $1\mu\text{F}/25\text{V}$ metal film or ceramic high frequency capacitor. When a filter inductor L1 is connected in series with the power converter input, an input capacitor C0 should be added. An input capacitor C0 should also be used when the input wiring is long, since the wiring can act as an inductor. Failure to use an input capacitor under these conditions can produce large input voltage spikes and an unstable output.

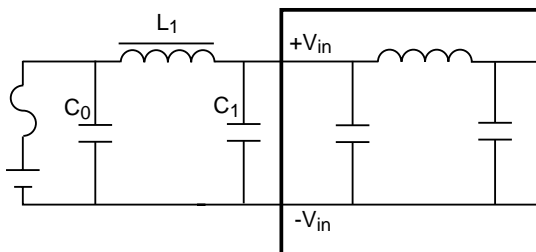

Fig.4 EMI Reduction Input Filter

Remote On/Off Control (optional)

The AEE-10W 12V input dual output is negative logic, remote on/off turns the module off during a logic high on the remote on/off pin, and turns the module on during a logic low on the remote on/off pin.

To turn the power module on or off, the user must supply a switch to control the voltage on the remote on/off pin, the switcher may be an open collector or equivalent (see Fig.5.).

The logic low is $V_{on/off} = 0\text{V}$ to $+0.7\text{V}$.

The logic high is $V_{on/off} = +3.6\text{V}$ to $+6\text{V}$.

The module has not internal capacitance to reduce noise at the on/off pin. Additional capacitance is needed. A $1\mu\text{F}/25\text{V}$ electrolytic capacitor is recommended for C1.

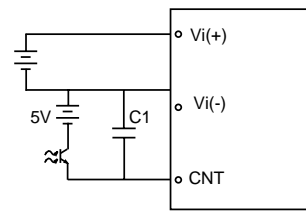

V_{cnt} : ON--- $V_{cnt} = 0 \sim +0.7\text{V}$ or CNT pin in midair
 OFF--- $V_{cnt} = +3.6\text{V} \sim +6\text{V}$
 C1: Recommended $1\text{mF}/25\text{V}$

Fig.5 Remote On/Off Control

Input-Output Characteristic

Isolation:

The isolation voltage between input to output, input to case and case to output are all greater than 1500 Volt DC. If the system using the power module needs to meet safety agency approval, certain rules must be followed in the design of the system using the module. In particular, all of the creepage and clearance requirements of the end-use safety requirement must be observed. Also specific applications need to receive other or additional requirements.

Safety Consideration:

For safety-agency approval of the system in which the power module is used, the power module must be installed in compliance with the spacing and separation requirements of the end-use safety agency standard, i.e., UL1950, CSA C22.2 No. 950-95, and EN60950. The input-to-output 1500VDC isolation is an operational insulation. The DC/DC power module should be installed in end-use equipment, in compliance with the requirements of the ultimate application, and is intended to be supplied by an isolated secondary circuit. When the supply to the DC/DC power module meets all the requirements for SELV(<60Vdc), the output is considered to remain within SELV limits (level 3). If connected to a 60Vdc power system, double or reinforced insulation must be provided in the power supply that isolates the input from any hazardous voltages, including the ac mains. One Vi pin and one Vo pin are to be grounded or both the input and output pins are to be kept floating. Single fault testing in the power supply must be performed in combination with the DC/DC power module to demonstrate that the output meets the requirement for SELV. The input pins of the module are not operator accessible.

Note: Do not ground either of the input pins of the module, without grounding one of the output pins. This may allow a non-SELV voltage to appear between the output pin and ground.

Output Characteristics

Minimum Load Requirements:

There is **no minimum load requirement** for AEE-10W 12Vin dual output series modules.

Output Trimming:

AEE-10W 12V input dual output series does not have trim function.

Output Over-Current Protection:

AEE-10W 12V input series DC/DC converters feature foldback current limiting as part of their Overcurrent Protection (OCP) circuits. When output current exceeds 110 to 150% of rated current, such as during a short circuit condition, the output will shutdown. **Note if input voltage exceeds 20V, the continuous shortcircuit may damage the module or decrease its life.**

Output Filters

When the load is sensitive to ripple and noise, an output filter can be added to minimize the effects. A simple output filter to reduce output ripple and noise can be made by connecting a capacitor across the output as shown in Figure 6. The recommended value for the output capacitor is 100µF/25V.

Extra care should be taken when long leads or traces are used to provide power to the load. Long lead lengths increase the chance for noise to appear on the lines. Under these conditions C2 can be added across the load as shown in Figure 7. The recommended component for C2 is 100µF/25V capacitor and connecting a 0.47µF/25V ceramic capacitor in parallel generally.

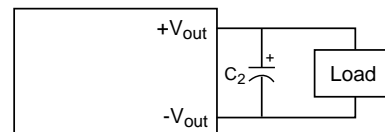

Fig.6 Output Ripple Filter

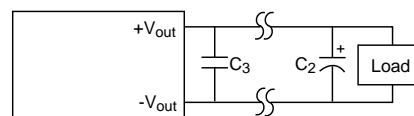

Fig.7 Output Ripple Filter For a Distant Load

Decoupling

Noise on the power distribution system is not always created by the converter. High speed analog or digital loads with dynamic power demands can cause noise to cross the power inductor back onto the input lines. Noise can be reduced by decoupling the load. In most cases, connecting a 10 μF tantalum capacitor in parallel with a 0.1μF ceramic capacitor across the load will decouple it. The capacitors should be connected as close to the load as possible.

Ground Loops

Ground loops occur when different circuits are given multiple paths to common or earth ground, as shown in Figure 8. Multiple ground points can slightly different potential and cause current flow through the circuit from one point to another. This can result in additional noise in all the circuits. To eliminate the problem, circuits should be designed with a single ground connection as shown in Figure 9.

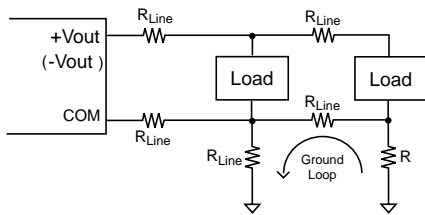

Fig.8 Ground Loops

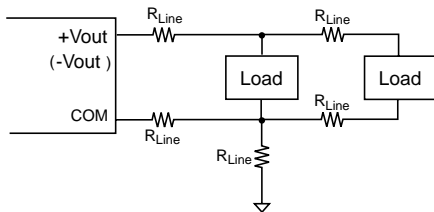

Fig.9 Single Point Ground

Parallel Power Distribution

Figure 10 shows a typical parallel power distribution design. Such designs, sometimes called daisy chains, can be used for very low output currents, but are not normally recommended. The voltage across loads far from the source can vary greatly depending on the IR drops along the leads and changes in the loads closer to the source. Dynamic load conditions increase the potential problems.

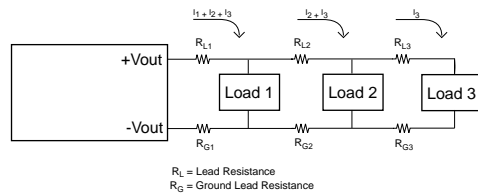

Fig.10 Parallel Power Distribution

Radial Power Distribution

Radial power distribution is the preferred method of providing power to the load. Figure 11 shows how individual loads are connected directly to the power source. This arrangement requires additional power leads, but it avoids the voltage variation problems associated with the parallel power distribution technique.

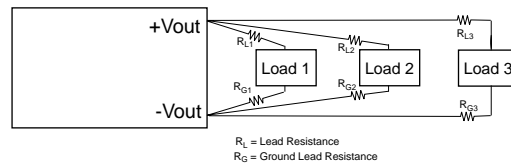

Fig.11 Radial Power Distribution

Mixed Distribution

In the real world a combination of parallel and radial power distribution is often used. Dynamic and high current loads are connected using a

radial design, while static and low current loads can be connected in parallel. This combined approach minimizes the drawbacks of a parallel design when a purely radial design is not feasible.

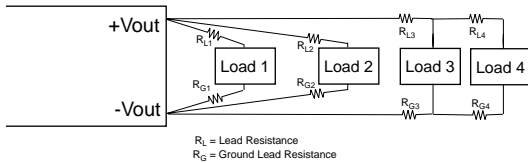

Fig. 12 Mixed Power Distribution

Redundant Operation

A common requirement in high reliability systems is to provide redundant power supplies. The easiest way to do this is to place two converters in parallel, providing fault tolerance but not load sharing. Oring diodes should be used to ensure that failure of one converter will not cause failure of the second. Figure 13 shows such an arrangement. Upon application of power, one of the converters will provide a slightly higher output voltage and will support the full load demand. The second converter will see a zero load condition and will “idle”. If the first converter should fail, the second converter will support the full load. When designing redundant converter circuits, Schottky diodes should be used to minimize the forward voltage drop. The voltage drop across the Schottky diodes must also be considered when determining load voltage requirements.

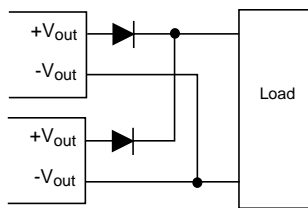

Fig.13 Redundant Operation

**AEE-10W 12V Input
 Dual Output Series
 Mechanical Considerations**

Installation

Although AEE-10W 12V input dual output series converters can be mounted in any orientation, free air-flowing must be taken. Normally power components are always put at the end of the airflow path or have the separate airflow paths. This can keep other system equipment cooler and increase component life spans.

Soldering

AEE-10W 12V input dual output series converters are compatible with standard wave soldering techniques. When wave soldering, the converter pins should be preheated for 20-30 seconds at 110°C, and wave soldered at 260°C for less than 10 seconds.

When hand soldering, the iron temperature should be maintained at 425°C and applied to the converter pins for less than 5 seconds. Longer exposure can cause internal damage to the converter. Cleaning can be performed with cleaning solvent IPA or with water.

MTBF

The MTBF, calculated in accordance with Bellcore TR-NWT-000332 is 3,000,000 hours. Obtaining this MTBF in practice is entirely possible. If the ambient air temperature is expected to exceed +25°C, then we also advise a oriented for the best possible cooling in the air stream.

ASTEC can offer custom solutions. Please contact the factory for details.

Module Derating

Typical derating curves

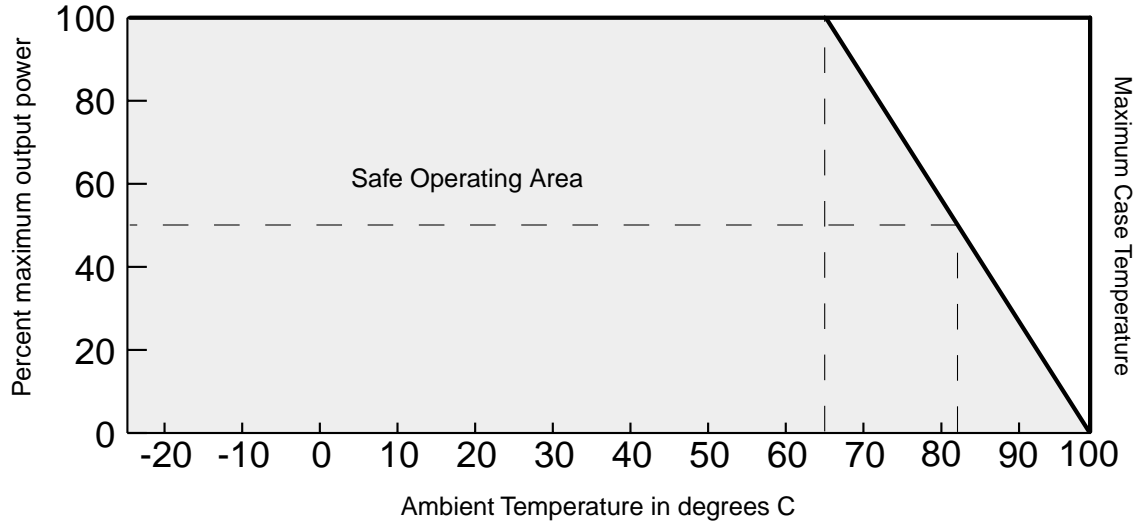

Mechanical Chart:

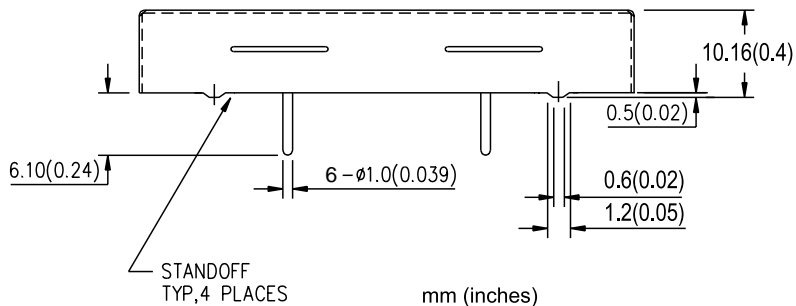
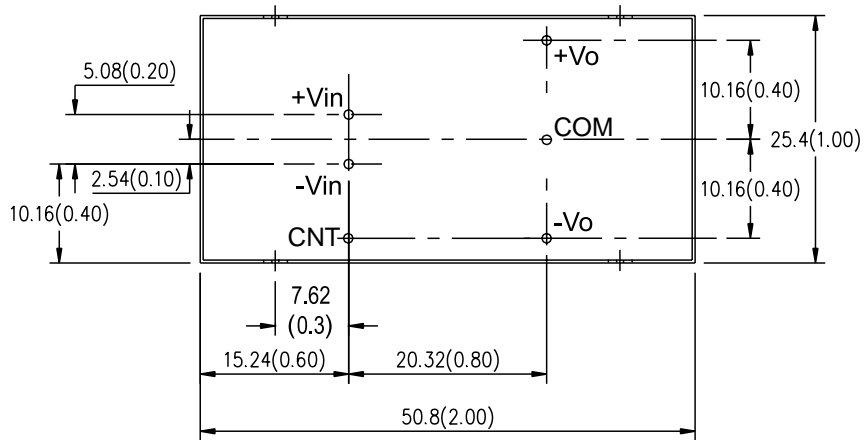

AEE-10W 12V Input Series DC-DC Converters
±5V, ±12V, ±15V 10 Watt Dual Output

Electrical Specs

	Nominal Input (V)	Output Voltage (V)	Output Current (A)	Ripple		Noise		Efficiency		Capacitive
				(mV rms)		(mV pp)		(%)		Load
				typ	max	typ	max	min	typ	(µf)
AEE02F12*	12	3.3	2.5	7	20	40	75	75	76	1000
AEE02A12*	12	5	2	7	20	40	75	77	78	1000
AEE01B12*	12	12	0.84	10	20	30	75	81	82	100
AEE01C12*	12	15	0.67	10	20	30	75	81	82	100
AEE02F24**	24	3.3	2.5	7	20	40	75	75	76	1000
AEE02A24**	24	5	2	7	20	40	75	77	78	1000
AEE01B24**	24	12	0.84	10	20	30	75	81	82	100
AEE01C24**	24	15	0.67	10	20	30	75	81	82	100
AEE02F48**	48	3.3	2.5	7	20	40	75	75	77	1000
AEE02A48**	48	5	2	7	20	40	75	77	80	2200
AEE01B48**	48	12	0.84	10	20	30	75	81	82	330
AEE01C48**	48	15	0.67	10	20	30	75	81	8	330
AEE01AA12*	12	±5	±1	10	20	60	100	77	79	100***
AEE00BB12*	12	±12	±0.42	10	20	90	100	81	83	100***
AEE00CC12*	12	±15	±0.33	10	20	90	100	81	83	47***
AEE01AA24	24	±5	±1	10	20	60	100	77	79	100***
AEE00BB24	24	±12	±0.42	10	20	90	100	81	83	100***
AEE00CC24	24	±15	±0.33	10	20	90	100	81	83	47***
AEE01AA48	48	±5	±1	10	20	60	100	77	79	100***
AEE00BB48	48	±12	±0.42	10	20	90	100	81	85	150***
AEE00CC48	48	±15	±0.33	10	20	90	100	81	83	47***

* The detailed information can reference to the “ AEE-10W 12V input series application manual”.

** The detailed information can reference to the “ AEE-10W signal output series application manual”.

*** “ Load per output.