

ADAPTERS

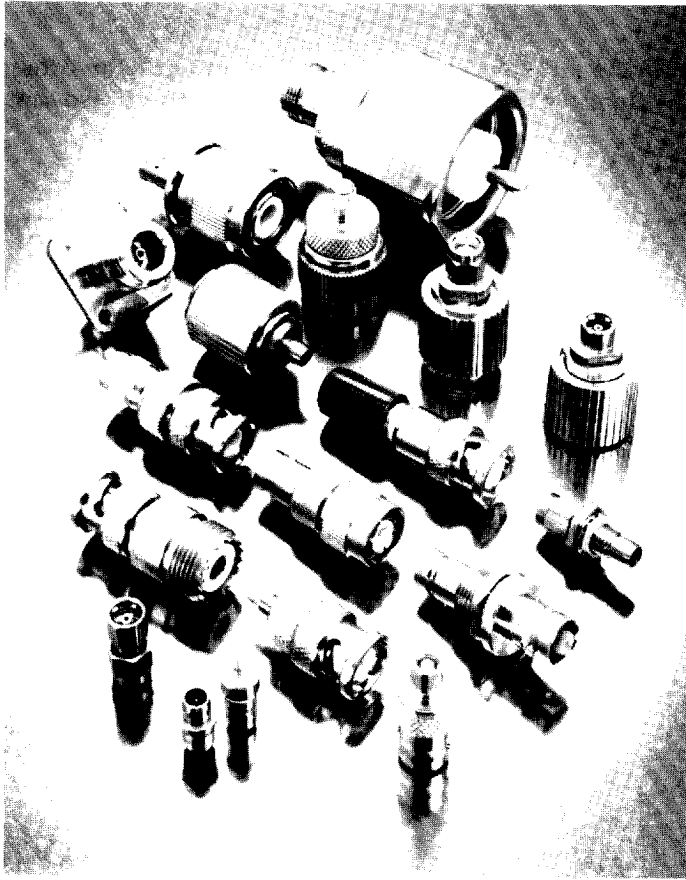

BETWEEN-SERIES COAXIAL ADAPTERS

RADIALL'S between-series adapters are used to make efficient low loss transitions between different series of coaxial connectors.

They are widely used in laboratory test applications and in system equipment applications where different connector types must be mated.

All RADIALL adapters are designed to offer the lowest VSWR attainable across the frequency range of the connectors involved.

The following selection guide is provided to help the user find the corresponding page in this catalog for the proper between-series adapter required.

CONTENTS

	Page
General	3
SELECTION GUIDE	4 - 5
BETWEEN SERIES ADAPTERS	6 - 34
Chronological table of Radiall part numbers	35
UG part numbers	35

All dimensions are given in inches (millimeters)

APC 7[®] TRADE MARK AMPHENOL

ADAPTERS

SELECTION GUIDE

Select one of the connector interface in the left hand column and line up with the other connector interface as shown in the row across the top. The intersection of these two will give the appropriate page number.

		APC7	SMA		SMA3,5		SMB		SMC		SSMA		SSMB		BNC50Ω		BNC75Ω	
		7mm	P	J	P	J	J	P	J	P	P	J	J	P	P	J	P	J
SMA	P	32	○	○							7	7	7			12		
	J	32	○	○							7				13			
BMA	P	9	8	$\frac{8}{9}$														
	J	9	8	8														
SMB	J	33				○	○								13	13		
	P	33				○	○								14	14		
BNC	P	31		13		13	14	14							○	○	○	○
	J	31	12			13	14	14	15						○	○	○	○
N	P	$\frac{31}{34}$	21	21	22	23	$\frac{23}{24}$	24							17	17	17	17
	J	$\frac{32}{34}$	$\frac{21}{22}$	22	23	23	24	24	$\frac{24}{25}$	25					17	17	17	18
C	P	32														12		
	J	32					26											
MQ	P						29										27	
	J						$\frac{29}{30}$								27	27		
APC7	7mm		32	32	33	33	33	33	33	33	34	34	34			31	31	

- Please note that when « plug » or « jack » (P - J) terminology is used, it refers to the connector's style of each adapter's end.
- All adapters interfaces meet or exceed the requirements of MIL-STD-348.
- For all in-series adapters, please refer to the Radiall connector catalog for specific series.

ADAPTERS SELECTION GUIDE

18		N 50Ω		N 75Ω		C		1,6/5,6		HN		LC		UHF		microdcl		sockets		ban- ana
J	P	J	P	J	P	J	P	J	P	J	P	J	P	J	P	J	Ø2	Ø4	Ø4	
		21	21 / 22																	
7		21	22																	
		23 / 24	24			26														
			24												10	10				
		17	17	17	17			11	11					12				15	15	
		17	17	17	18	12		11		12				12						16
		○	○	○	○			18	19	20										21
		○	○	○	○	19	19	19	19	20				20	20	21				
			19			○	○							26						
		18	19			○	○							26						26
			27	28	28															29
		27	28	28	28			29							29					
		31	31 / 34	32 / 34				31	32											

SMA to TNC

SMA PLUG to TNC PLUG

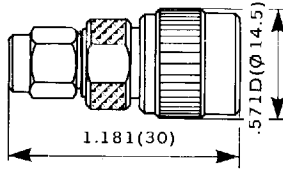
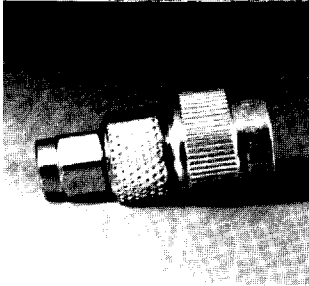

PART NUMBER	R 191 309
VSWR	0 - 11 GHz 1.22 Max.

SMA PLUG to TNC JACK

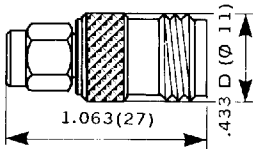
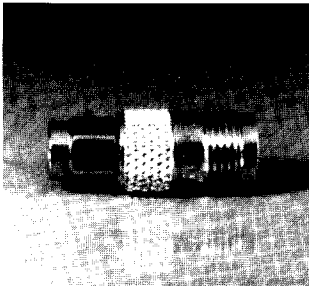

PART NUMBER	R 191 311
VSWR	0 - 11 GHz 1.22 Max.

SMA JACK to TNC PLUG

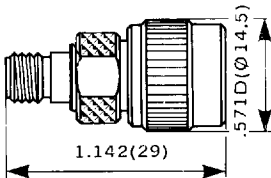
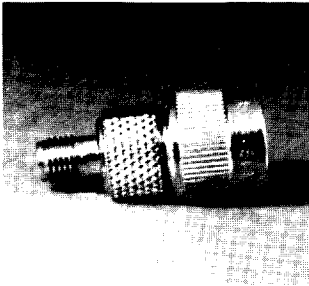

PART NUMBER	R 191 313
VSWR	0 - 11 GHz 1.22 Max.

SMA JACK to TNC JACK

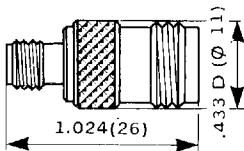
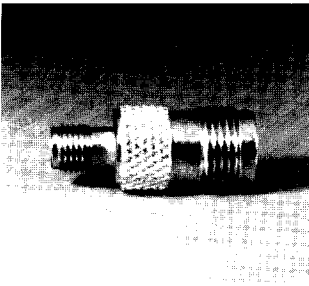

PART NUMBER	R 191 315
VSWR	0 - 11 GHz 1.22 Max.

SMA JACK to TNC JACK Square flange

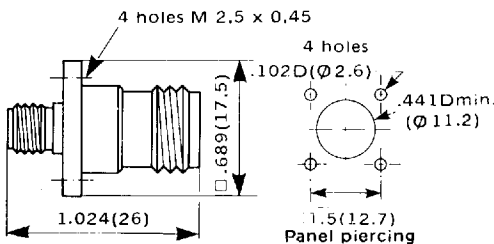
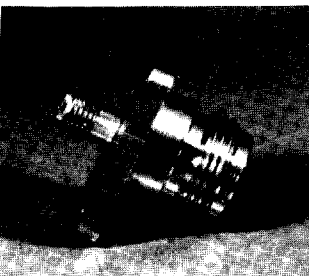

PART NUMBER	R 191 365
VSWR	0 - 11 GHz 1.22 Max.

SMA to TNC/SSMA/SSMB

SMA / SMA 3,5 JACK to TNC 18 GHz JACK Panel sealed, bulkhead feedthrough

PART NUMBER	R 191 314 700	R 191 316 700
VSWR	0 - 18 GHz 1.50 Max.	0 - 18 GHz 1.06 +0.01 F (GHz)
Inner seal	YES	NO
Connector	SMA	SMA 3,5

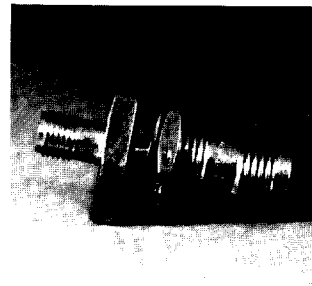
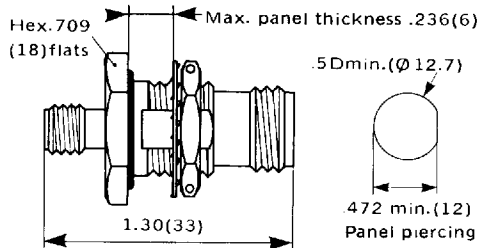

SMA PLUG to SSMA JACK

PART NUMBER	R 191 347
-------------	-----------

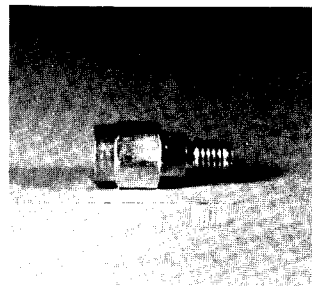
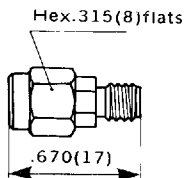

SMA JACK to SSMA JACK

PART NUMBER	R 191 349
-------------	-----------

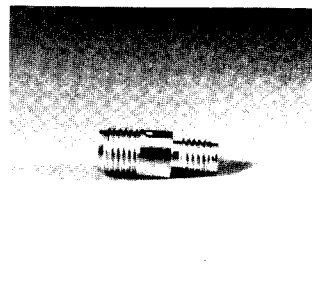
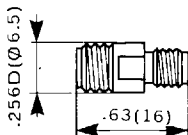

SMA PLUG to SSMB PLUG

PART NUMBER	R 191 374
-------------	-----------

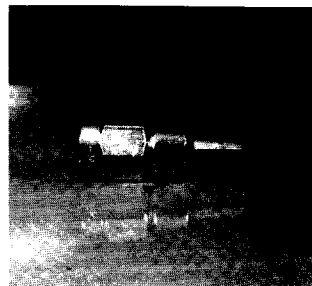
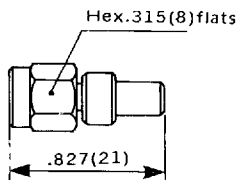

SMA PLUG to SSMB JACK

PART NUMBER	R 191 376
-------------	-----------

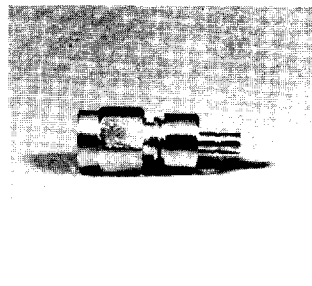
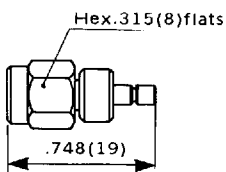

BMA to SMA

BMA PLUG to SMA PLUG

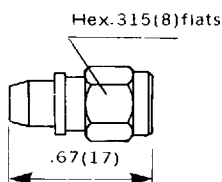
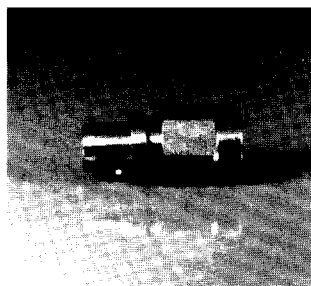

PART NUMBER	R 191 350 001
VSWR	0 - 18 GHz 1.05 + 0.005 F (GHz)

BMA JACK to SMA PLUG

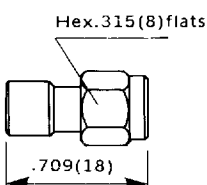
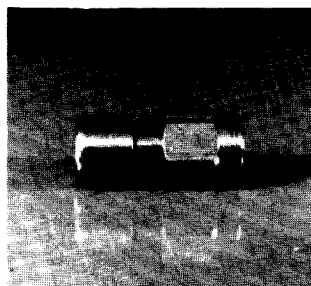

PART NUMBER	R 191 351 001
VSWR	0 - 18 GHz 1.05 + 0.007 F (GHz)

BMA PLUG to SMA JACK

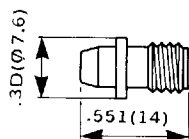
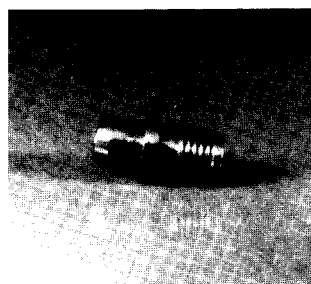

PART NUMBER	R 191 352 001
VSWR	0 - 18 GHz 1.05 + 0.005 F (GHz)

BMA JACK to SMA JACK

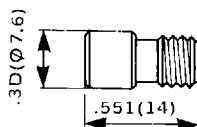
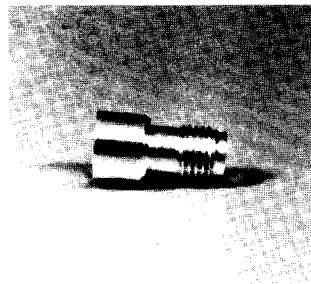

PART NUMBER	R 191 353 001
VSWR	0 - 18 GHz 1.05 + 0.007 F (GHz)

BMA PLUG to SMA PLUG Bulkhead feedthrough

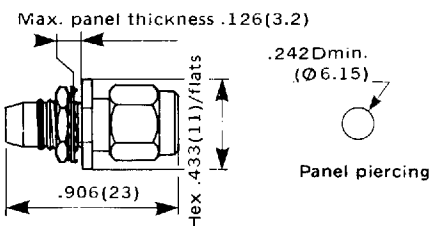
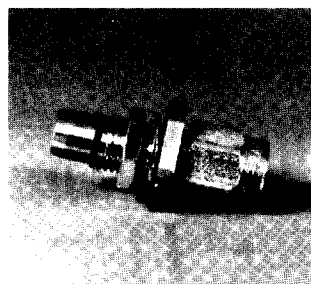

PART NUMBER	R 191 354 001
VSWR	0 - 18 GHz 1.05 + 0.005 F (GHz)

BMA to SMA/APC 7

BMA PLUG to SMA JACK Bulkhead feedthrough

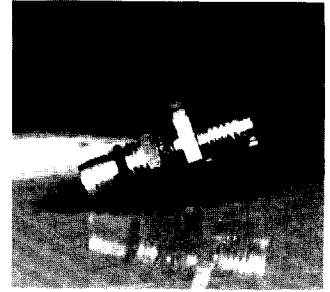
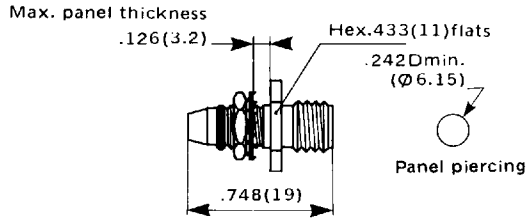

BMA PLUG to APC 7®

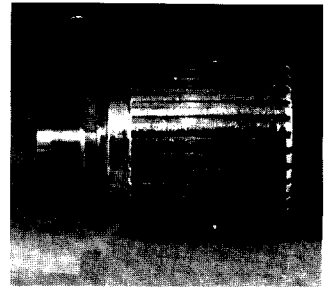
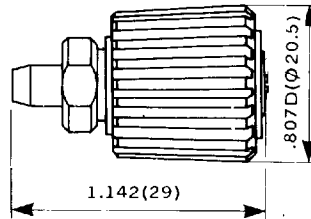

BMA JACK to APC 7®

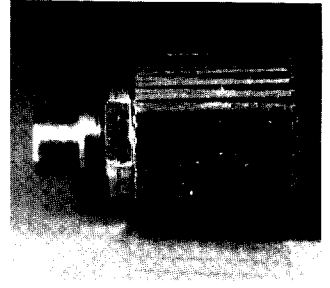
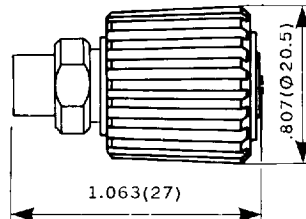

For our rack and bulkhead applications or your between modules assemblies, use BMA slide-in connectors.
(catalogs upon request)

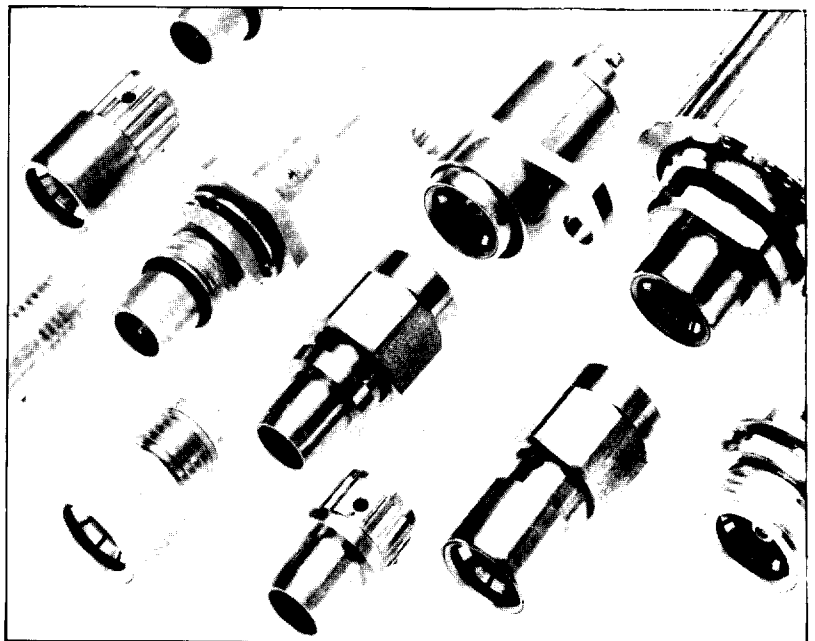

SMB to MICROCLIC

SMB PLUG to MICROCLIC PLUG

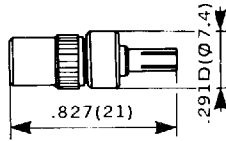

PART
NUMBER

R 191 265

SMB PLUG to MICROCLIC JACK

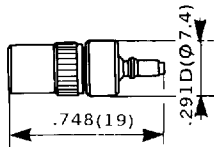
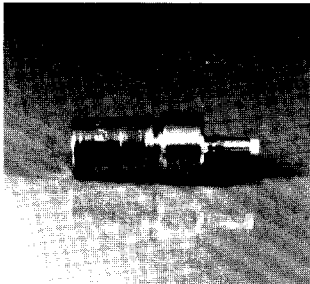

PART
NUMBER

R 191 267

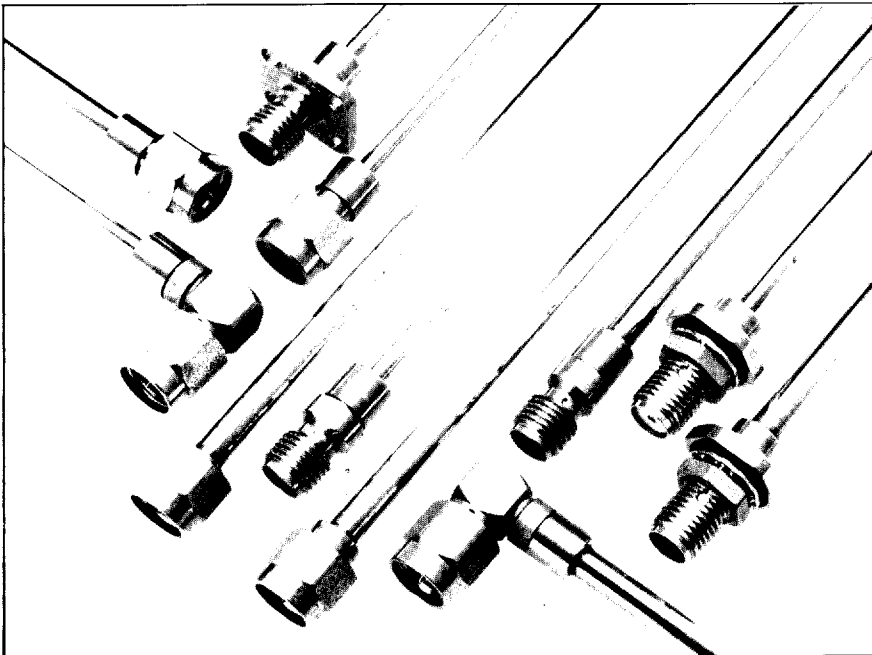

Save time during cabling and avoid soldering by using our SMA crimp on .085 and .141 semi-rigid cable connectors. *(catalogs upon request)*

BNC to TNC/1,6/5,6

BNC PLUG to TNC JACK

PART NUMBER	R 191 403
-------------	-----------

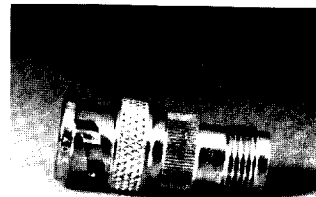
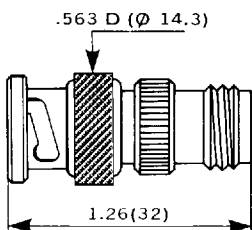

BNC JACK to TNC PLUG

PART NUMBER	R 191 405
-------------	-----------

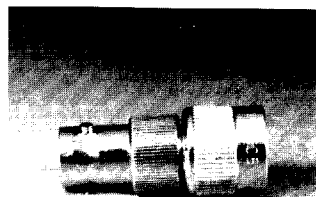
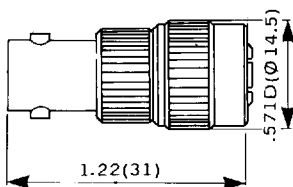

BNC PLUG to 1,6 / 5,6 JACK Screw - on , snap - on

PART NUMBER	R 192 430
Impedance	75 Ω

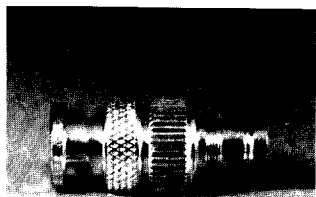
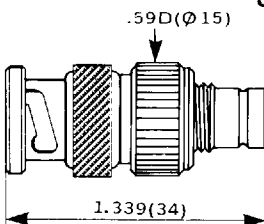

BNC PLUG to 1,6 / 5,6 PLUG Screw - on

PART NUMBER	R 192 431
Impedance	75 Ω

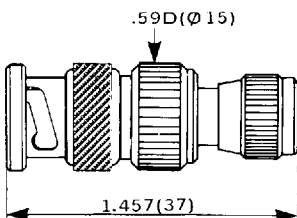

BNC JACK to 1,6 / 5,6 PLUG Screw - on

PART NUMBER	R 192 432
Impedance	75 Ω

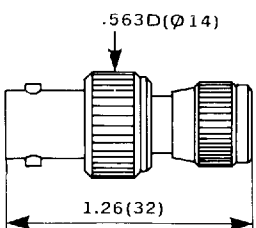

BNC to C/HN/UHF/SMA

BNC JACK to C PLUG

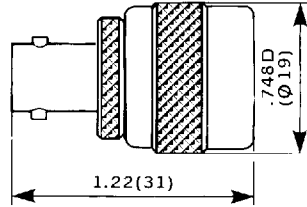
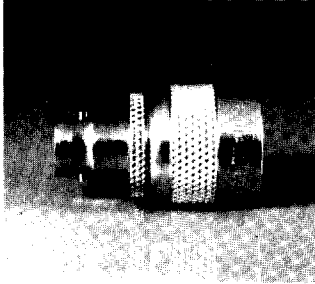

PART NUMBER	R 191 429
-------------	-----------

BNC JACK to HN PLUG

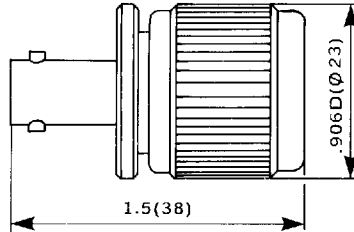
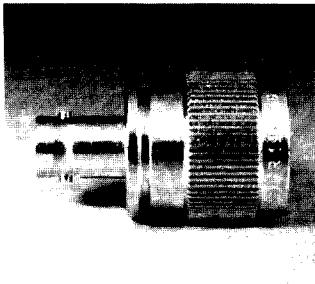

PART NUMBER	R 191 449
-------------	-----------

BNC PLUG to UHF JACK

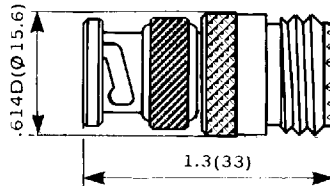
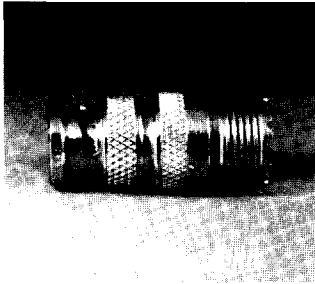

PART NUMBER	R 191 445
-------------	-----------

BNC JACK to UHF PLUG

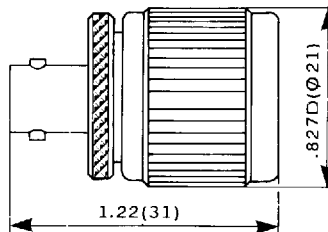
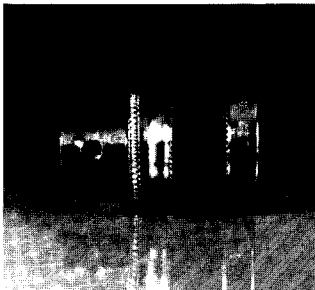

PART NUMBER	R 191 447
-------------	-----------

BNC JACK to SMA PLUG

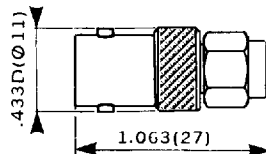
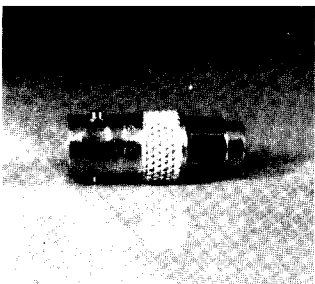

PART NUMBER	R 191 303
-------------	-----------

BNC to SMA/SMB

BNC PLUG to SMA JACK

PART NUMBER **R 191 305**

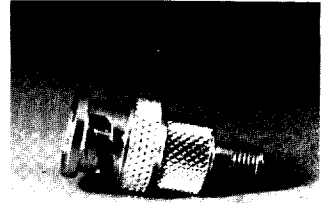
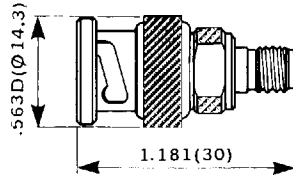

BNC PLUG to SMB JACK

PART NUMBER **R 191 209**

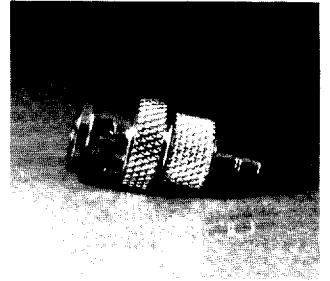
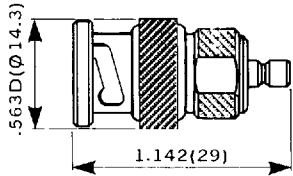

BNC JACK to SMB JACK Bulkhead feedthrough

PART NUMBER **R 191 211 ***

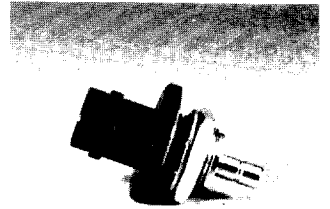
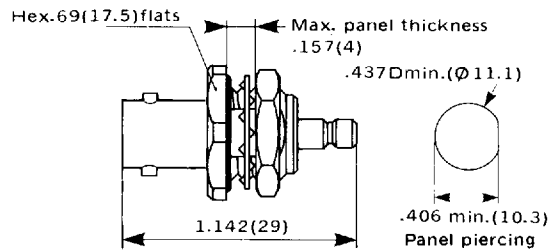

★ Chrome plated black

BNC JACK to SMB JACK Square flange

PART NUMBER **R 191 212**

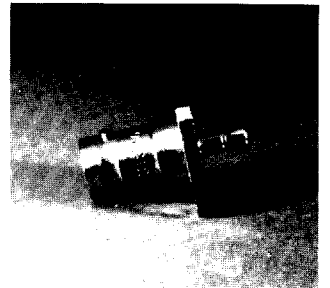
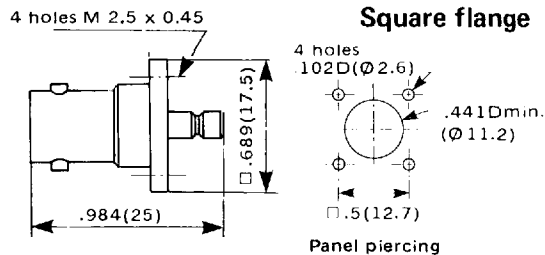

BNC JACK to SMB JACK Panel sealed, bulkhead feedthrough

PART NUMBER **R 191 213**

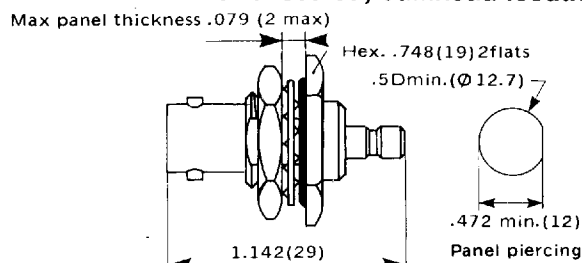

BNC to SMB/SMC

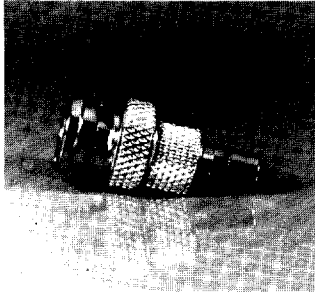

BNC PLUG to SMB PLUG

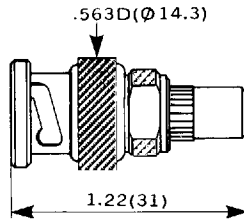

PART NUMBER	R 191 214
-------------	-----------

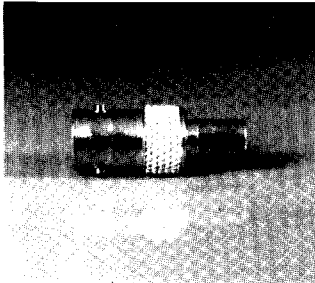

BNC JACK to SMB PLUG

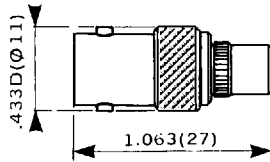

PART NUMBER	R 191 215
-------------	-----------

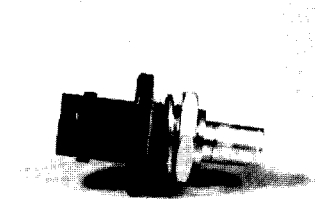

BNC JACK to SMB PLUG
Panel sealed, bulkhead feedthrough

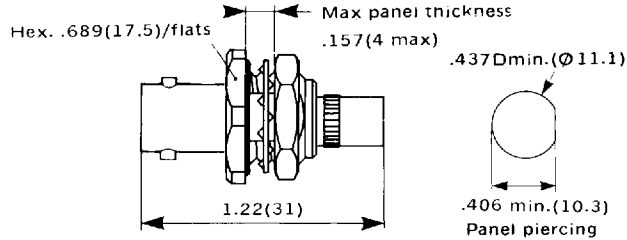

PART NUMBER	R 191 216 ★
-------------	-------------

★ Chrome plated black

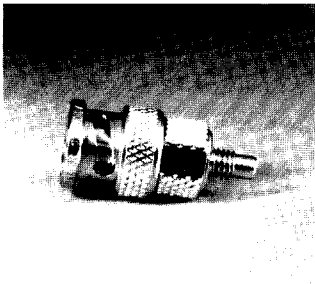

BNC PLUG to SMC JACK

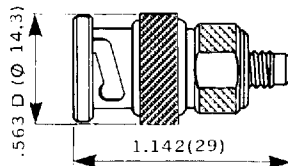

PART NUMBER	R 191 117
-------------	-----------

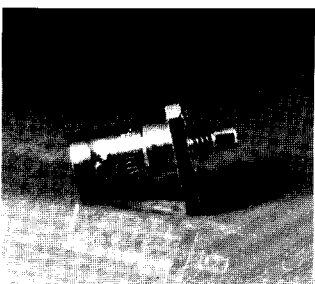

BNC JACK to SMC JACK
Square flange

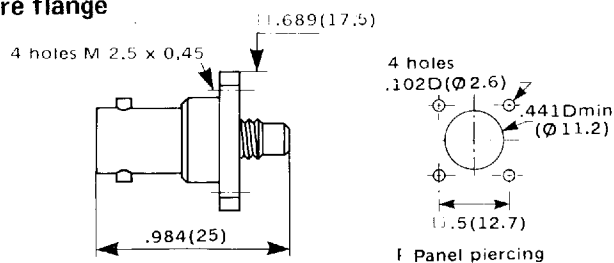

PART NUMBER	R 191 120
-------------	-----------

BNC to SMC/Contacts

BNC JACK to SMC PLUG

PART NUMBER **R 191 123**

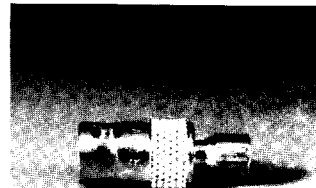
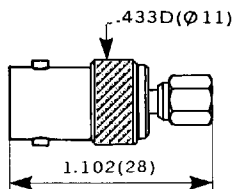

BNC JACK to SMC PLUG

Panel sealed, bulkhead feedthrough

PART NUMBER **R 191 124**

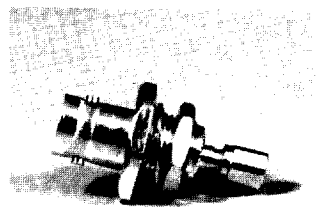
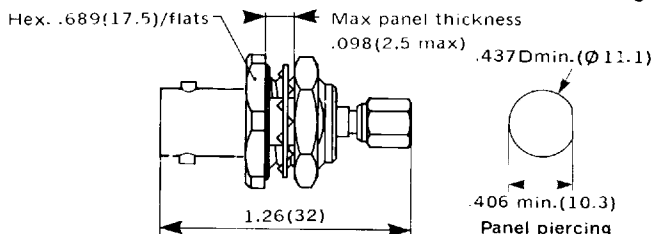

BNC PLUG to 2 SOCKET CONTACTS .079 D (Ø 2)

PART NUMBER **R 191 450**

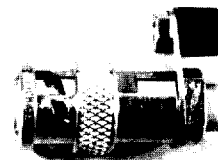
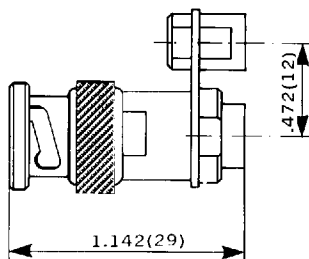

BNC PLUG to 2 SOCKET CONTACTS .157 D (Ø 4)

PART NUMBER **R 191 453**

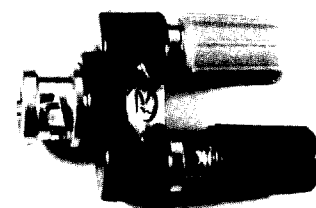
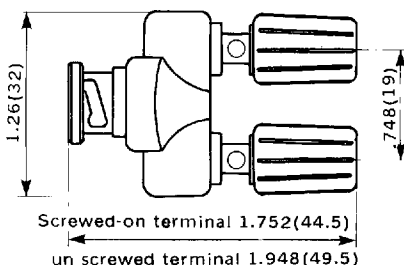

BNC PLUG to 1 SOCKET CONTACT .157D (Ø 4)

PART NUMBER **R 191 454**

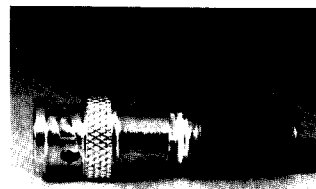
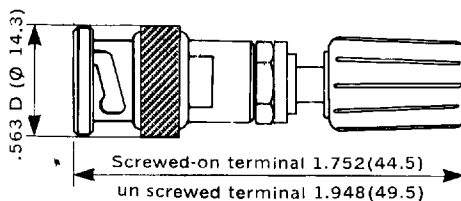

BNC to Banana

BNC JACK to 2 BANANA .157D (Ø4)

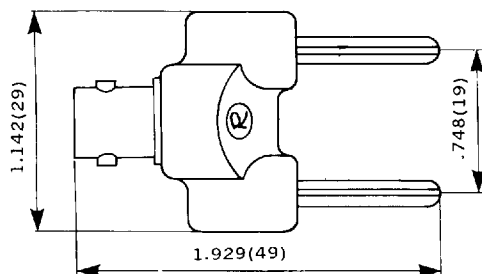
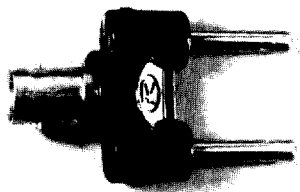

PART NUMBER	R 191 455
-------------	-----------



OTHER RADIALL PRODUCTS

- Miniature
SMA - SMB - SMC
- Standard
50 and 75 Ω BNC
50, 75 Ω , 18 GHz TNC
50 and 75 Ω N
UHF - Twinax
- High voltage
- RF hermetic seal
- RF cable assembly
- Accessories and assembly tools

N to BNC

N PLUG to BNC PLUG

PART NUMBER	R 191 417	R 192 417
Impedance	50 Ω	75 Ω
L	1.535(39)	1.457(37)

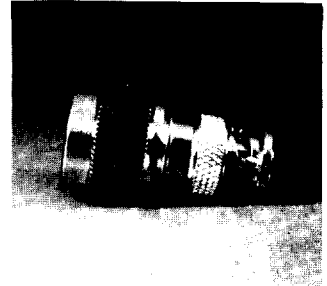
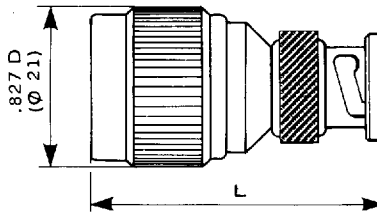

N JACK to BNC PLUG

PART NUMBER	R 191 419	R 192 419
Impedance	50 Ω	75 Ω
L	1.654(42)	1.496(38)

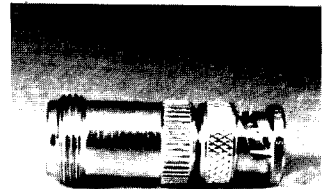
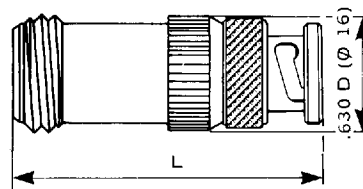

N PLUG to BNC JACK

PART NUMBER	R 191 421	R 192 421
Impedance	50 Ω	75 Ω

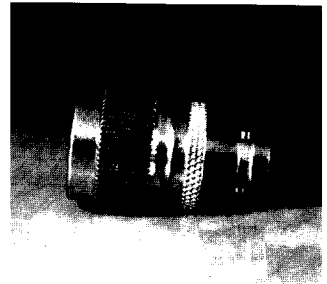
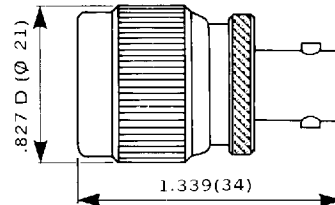

N JACK to BNC JACK Panel sealed, bulkhead feedthrough

PART NUMBER	R 191 422
-------------	-----------

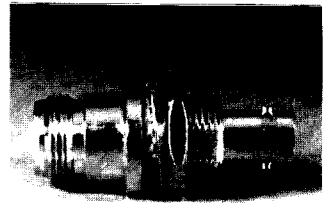
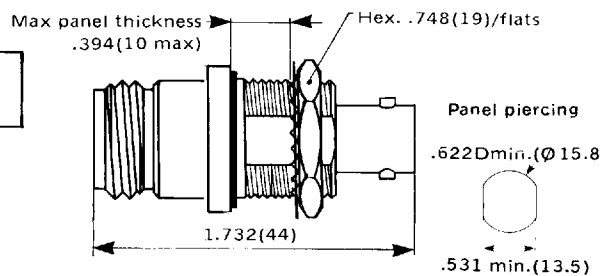

N JACK to BNC JACK

PART NUMBER	R 191 424	R 191 426
Panel sealed	NO	YES
L	1.378(35)	1.575(40)

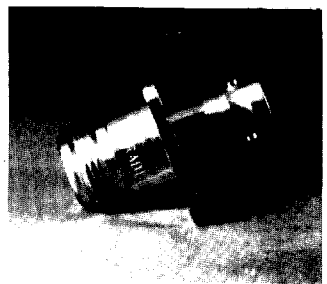
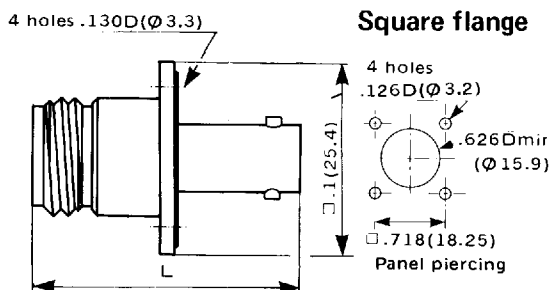

Gasket only for R 191 426

N to BNC/TNC/C

N JACK to BNC JACK

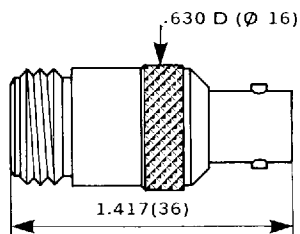
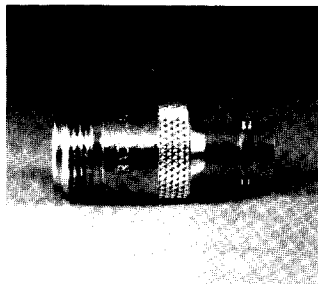

PART NUMBER	R 192 418
Impedance	75 Ω

N JACK to TNC PLUG

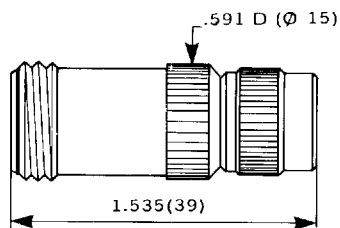
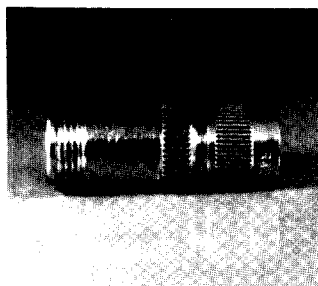

PART NUMBER	R 191 511
VSWR	0 - 11 GHz 1.22 Max.

N PLUG to TNC JACK

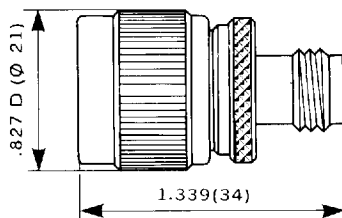
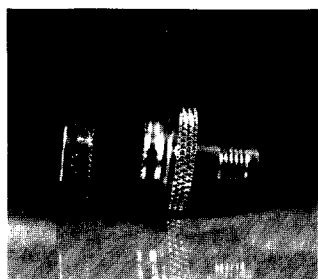

PART NUMBER	R 191 513
VSWR	0 - 11 GHz 1.22 Max.

N JACK to TNC JACK

Square flange

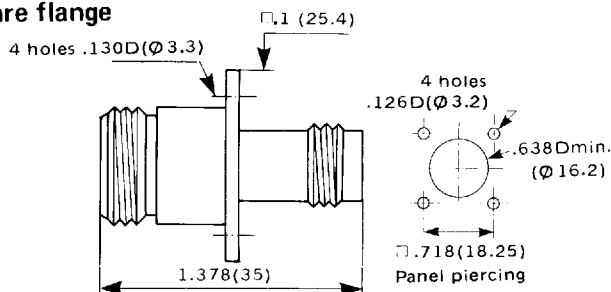
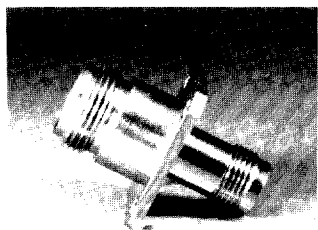

PART NUMBER	R 191 514
-------------	------------------

N PLUG to C JACK

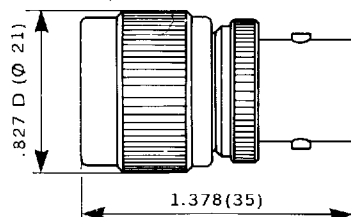
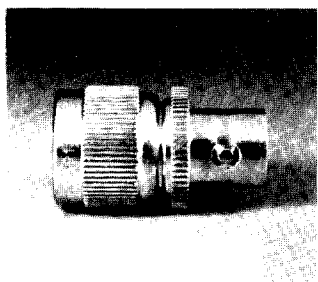

PART NUMBER	R 191 703
-------------	------------------

N to C/1,6/5,6

N JACK to C PLUG

PART NUMBER	R 191 705
-------------	-----------

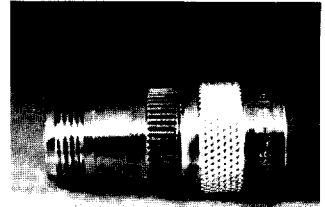
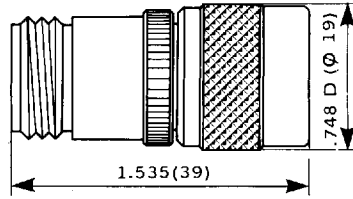

N JACK to C JACK Square flange

PART NUMBER	R 191 708
-------------	-----------

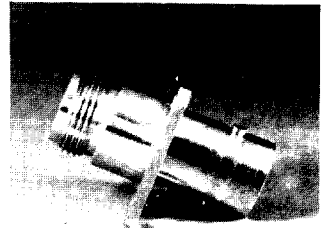
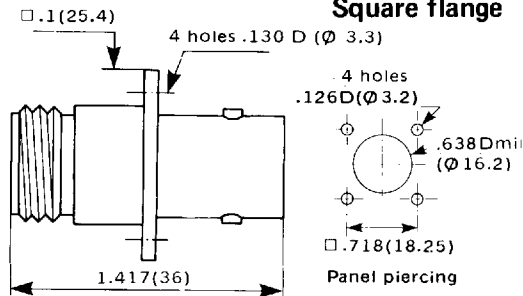

N JACK to 1,6 / 5,6 PLUG Screw-on

PART NUMBER	R 192 770
Impedance	75 Ω

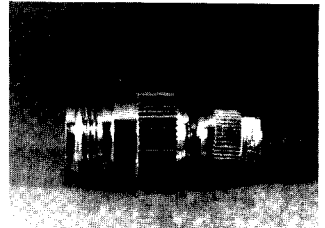
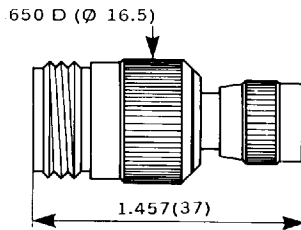

N JACK to 1,6 / 5,6 JACK Screw-on, snap-on

PART NUMBER	R 192 771
Impedance	75 Ω

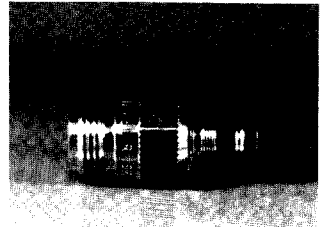
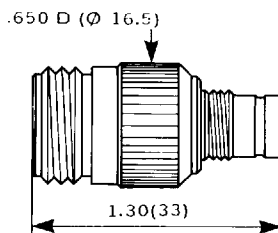

N PLUG to 1,6 / 5,6 PLUG Screw-on

PART NUMBER	R 192 775
Impedance	75 Ω

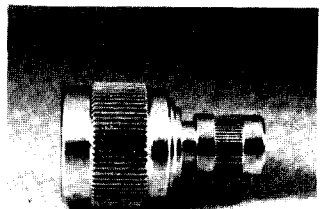
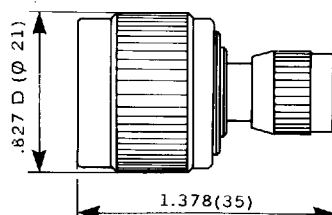

N to 1,6/5,6/LC/HN

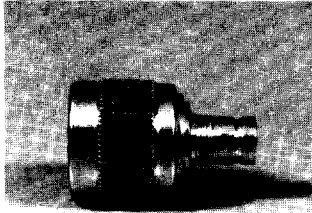

N PLUG to 1,6 /5,6 JACK
Screw-on , snap-on

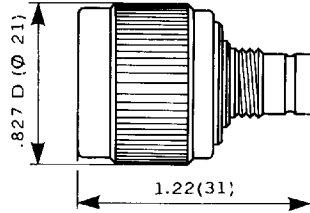

PART NUMBER	R 192 777
Impedance	75 Ω

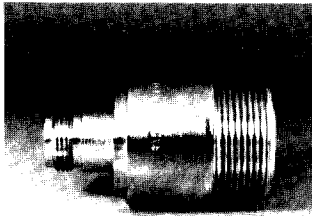

N JACK to LC JACK

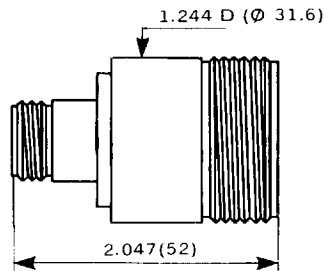

PART NUMBER	R 191 741
-------------	-----------

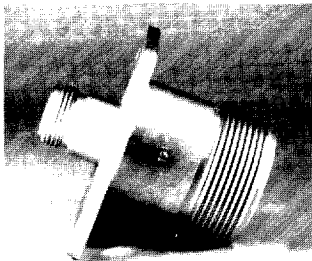

N JACK to LC JACK
Square flange

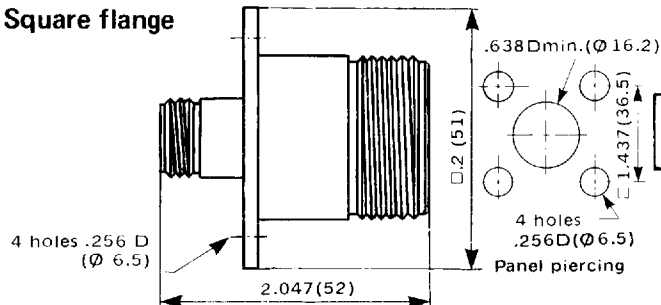

PART NUMBER	R 191 742
-------------	-----------

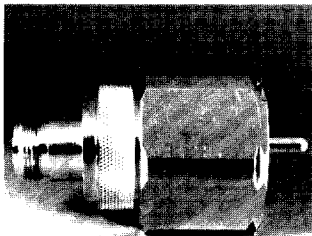

N JACK to LC PLUG

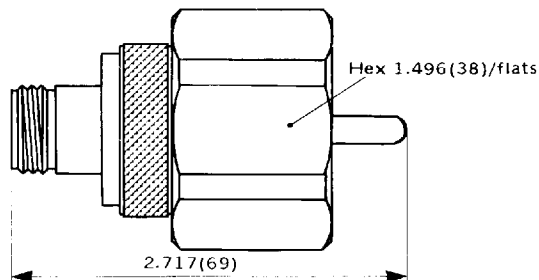

PART NUMBER	R 191 745
-------------	-----------

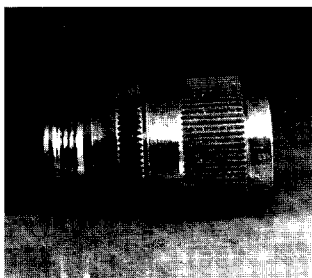

N JACK to HN PLUG

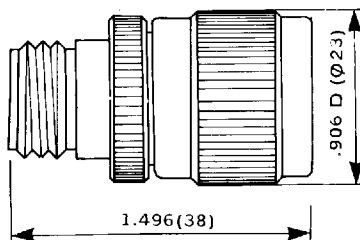

PART NUMBER	R 191 737
-------------	-----------

N to UHF/SMA

N PLUG to UHF JACK

PART NUMBER	R 191 731
-------------	------------------

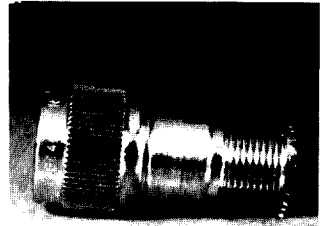
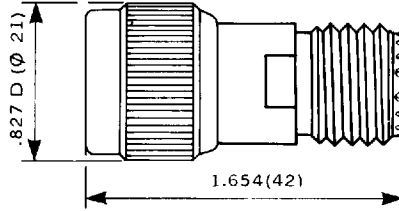

N JACK to UHF PLUG

PART NUMBER	R 191 733
-------------	------------------

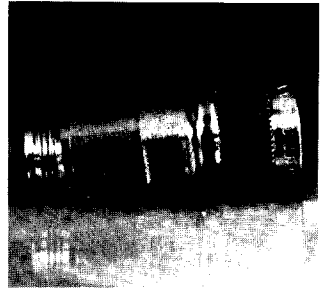
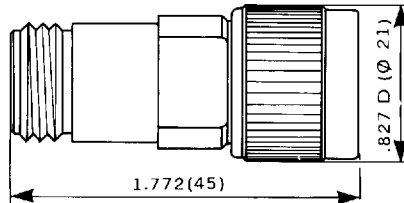

N PLUG to SMA PLUG

PART NUMBER	R 191 325
VSWR	0 - 11 GHz 1.06 + 0.005 F (GHz)

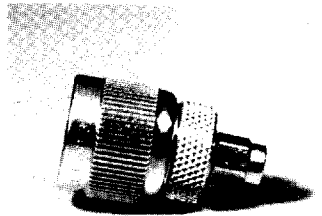
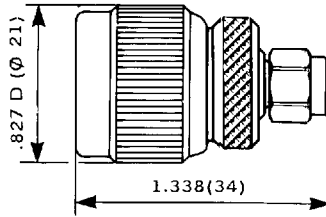

N JACK to SMA PLUG

PART NUMBER	R 191 327
VSWR	0 - 11 GHz 1.06 + 0.01 F (GHz)

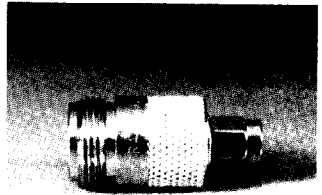
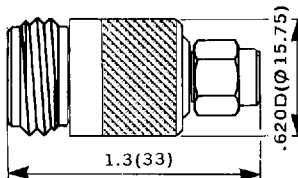

N PLUG to SMA JACK

PART NUMBER	R 191 329
VSWR	0 - 11 GHz 1.06 + 0.005 F (GHz)

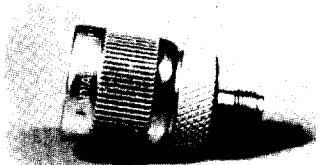
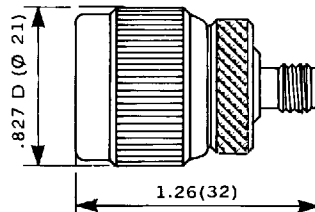

N to SMA/SMA 3,5

N JACK to SMA JACK

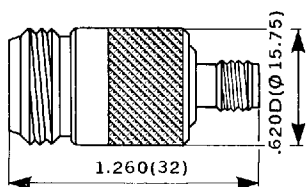
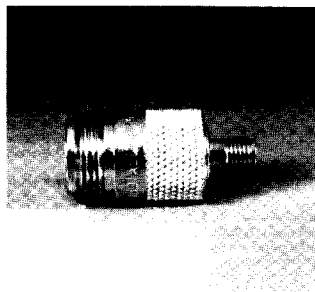

PART NUMBER	R 191 331
VSWR	0 - 11 GHz 1.06 + 0.01 F (GHz)

N JACK to SMA JACK Panel sealed, bulkhead feedthrough

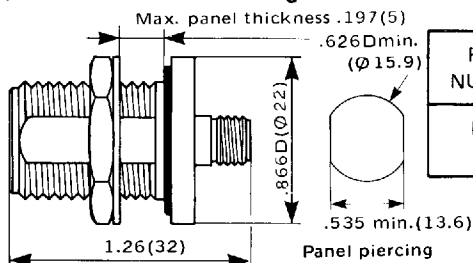
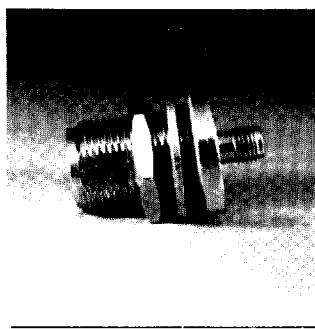

PART NUMBER	R 191 332	R 191 334
Inner seal	NO	YES

N JACK to SMA PLUG Square flange

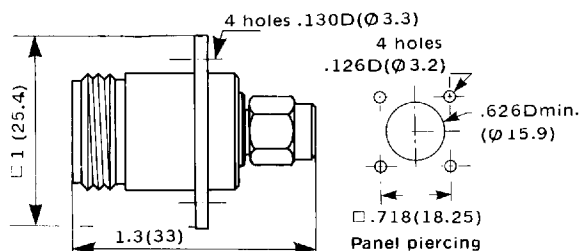
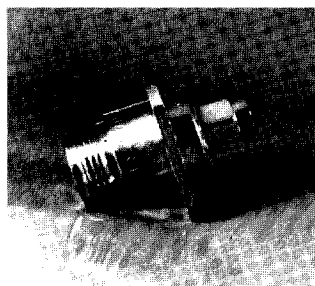

PART NUMBER	R 191 377
-------------	------------------

N JACK to SMA JACK Square flange

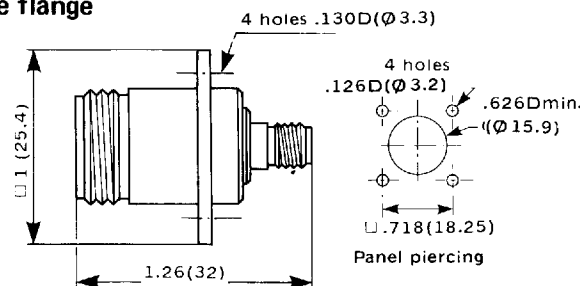
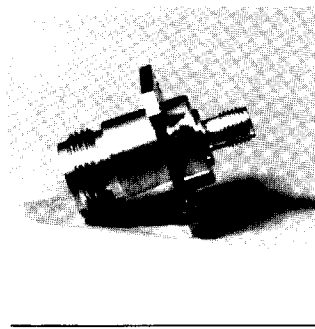

PART NUMBER	R 191 381
-------------	------------------

N PLUG to SMA 3.5 PLUG

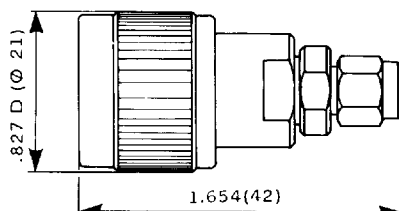
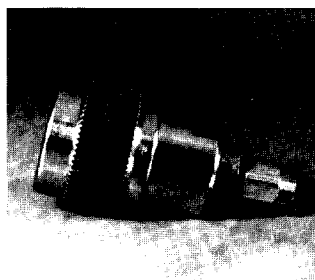

PART NUMBER	R 191 324
VSWR	0 - 18 GHz 1.03 + 0.005 F (GHz)

N to SMA 3,5/SMB

N JACK to SMA 3.5 PLUG

PART NUMBER	R 191 326
VSWR	0 - 18 GHz 1.03 + 0.005 F (GHz)

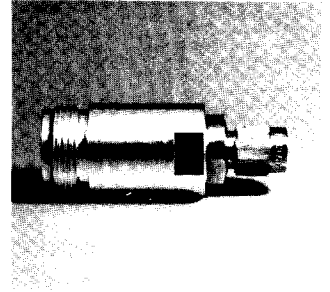
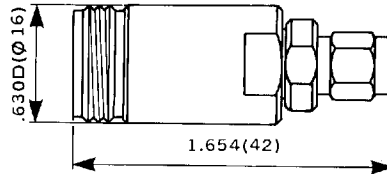

N PLUG to SMA 3.5 JACK

PART NUMBER	R 191 328
VSWR	0 - 18 GHz 1.03 + 0.005 F (GHz)

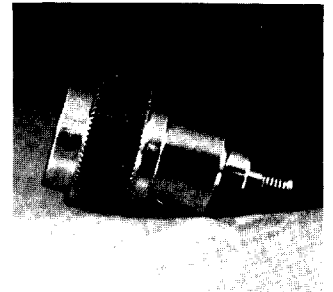
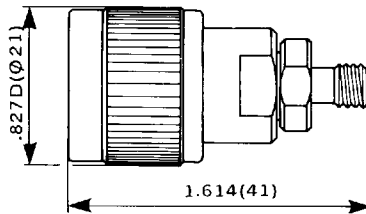

N JACK to SMA 3.5 JACK

PART NUMBER	R 191 330
VSWR	0 - 18 GHz 1.03 + 0.005 F (GHz)

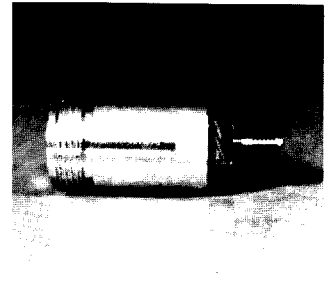
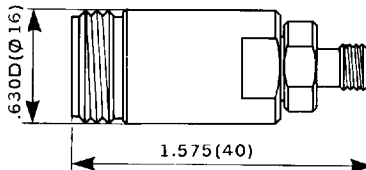

N JACK to SMA 3.5 JACK

PART NUMBER	R 191 333
VSWR	0 - 18 GHz 1.03 + 0.005 F (GHz)

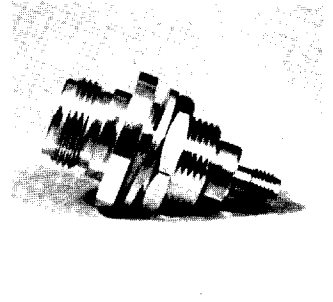
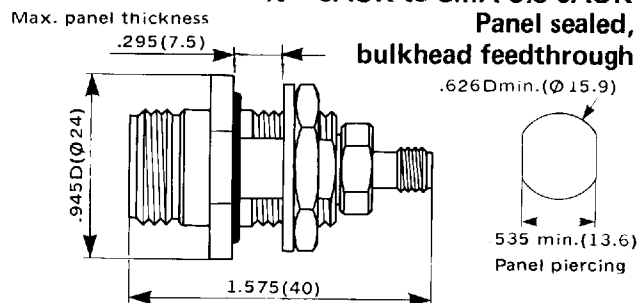

N PLUG to SMB JACK

PART NUMBER	R 191 233
VSWR	0 - 4 GHz 1.03 + 0.01 F (GHz)

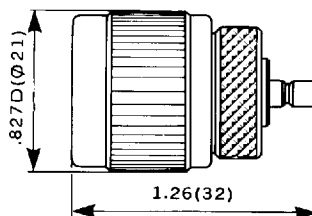

N to SMA 3,5/SMB

N JACK to SMA 3.5 PLUG

PART NUMBER	R 191 326
VSWR	0 - 18 GHz 1.03 + 0.005 F (GHz)

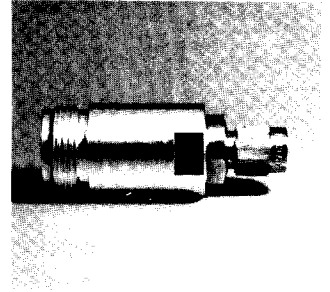
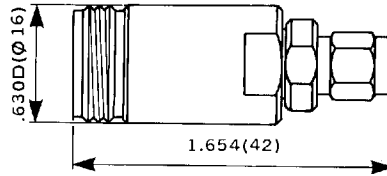

N PLUG to SMA 3.5 JACK

PART NUMBER	R 191 328
VSWR	0 - 18 GHz 1.03 + 0.005 F (GHz)

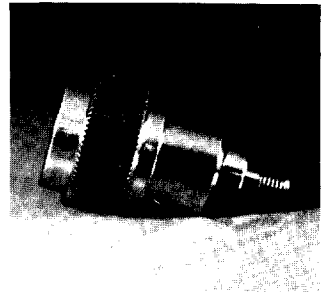
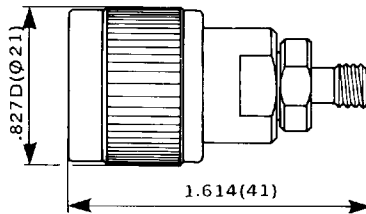

N JACK to SMA 3.5 JACK

PART NUMBER	R 191 330
VSWR	0 - 18 GHz 1.03 + 0.005 F (GHz)

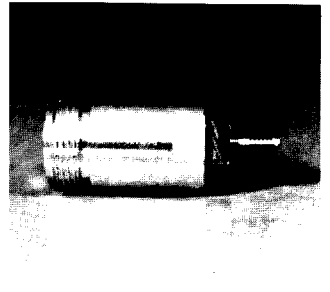
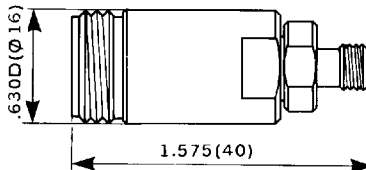

N JACK to SMA 3.5 JACK

PART NUMBER	R 191 333
VSWR	0 - 18 GHz 1.03 + 0.005 F (GHz)

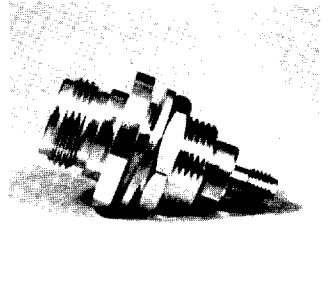
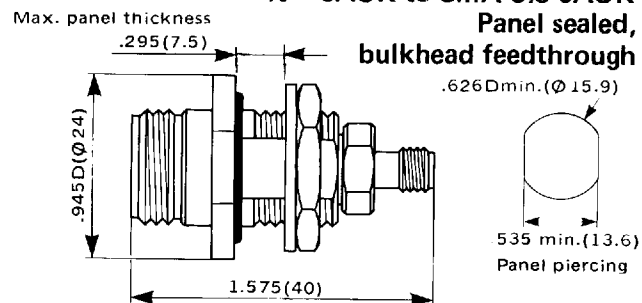

N PLUG to SMB JACK

PART NUMBER	R 191 233
VSWR	0 - 4 GHz 1.03 + 0.01 F (GHz)

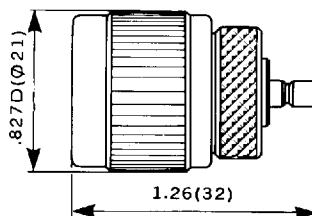

N to SMB/SMC



N PLUG to SMB JACK
Bulkhead feedthrough

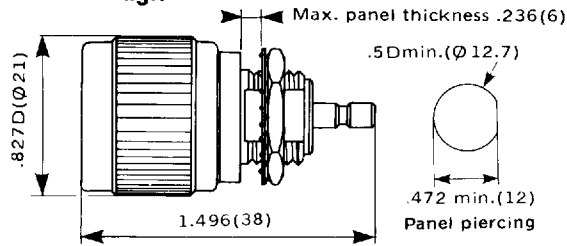

PART NUMBER	R 191 234
-------------	------------------

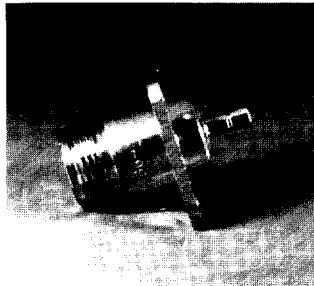

N JACK to SMB JACK
Square flange

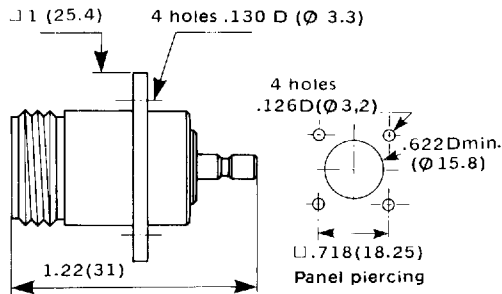

PART NUMBER	R 191 236
-------------	------------------

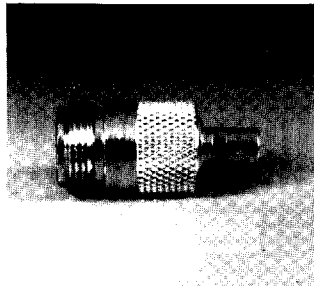

N JACK to SMB PLUG

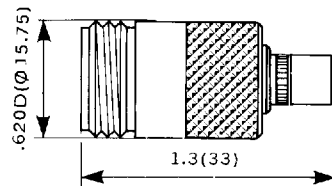

PART NUMBER	R 191 239
VSWR	0 - 4 GHz 1.03 + 0.03 F (GHz)

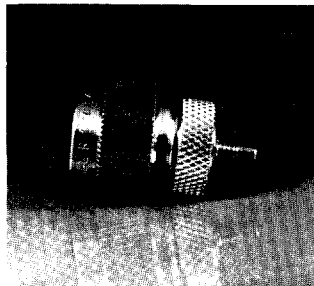

N PLUG to SMC JACK

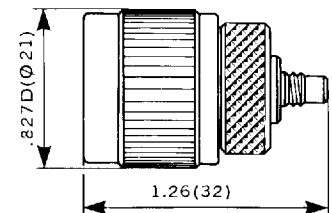

PART NUMBER	R 191 141
VSWR	0 - 11 GHz 1.35 Max.

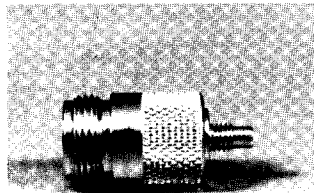

N JACK to SMC JACK

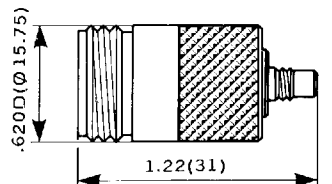

PART NUMBER	R 191 143
VSWR	0 - 11 GHz 1.35 Max.

N to SMC

N JACK to SMC JACK Panel sealed, square flange

PART NUMBER	R 191 144
VSWR	0 - 11 GHz 1.35 Max.

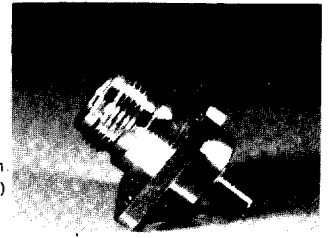
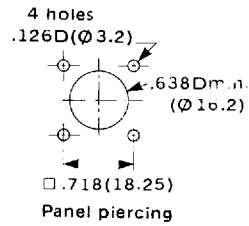
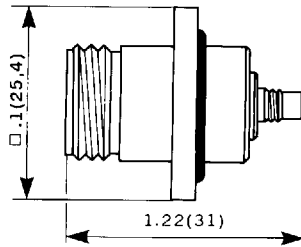

N JACK to SMC PLUG

PART NUMBER	R 191 147
VSWR	0 - 11 GHz 1.35 Max.

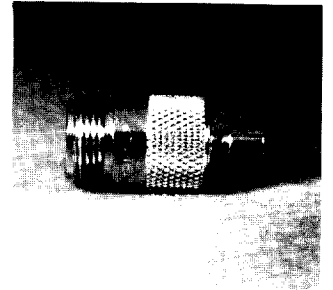
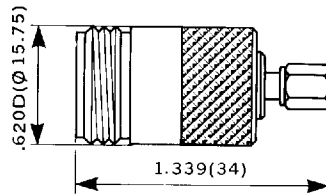

C to HN/UHF/SMB

C JACK to HN PLUG

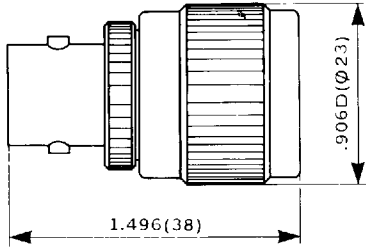
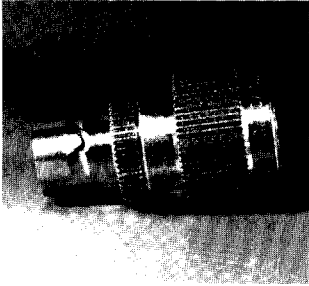

PART NUMBER	R 191 931
-------------	-----------

C PLUG to HN JACK

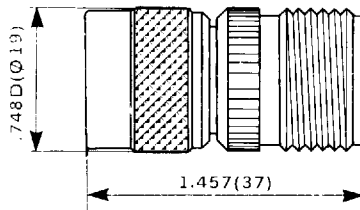
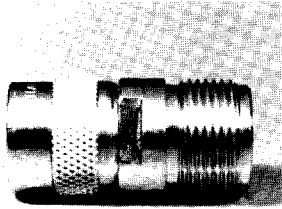

PART NUMBER	R 191 933
-------------	-----------

C JACK to UHF PLUG

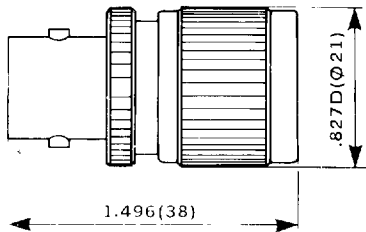
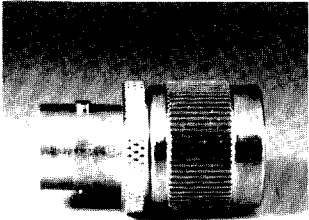

PART NUMBER	R 191 921
-------------	-----------

C JACK to SMB JACK Panel sealed, bulkhead feedthrough

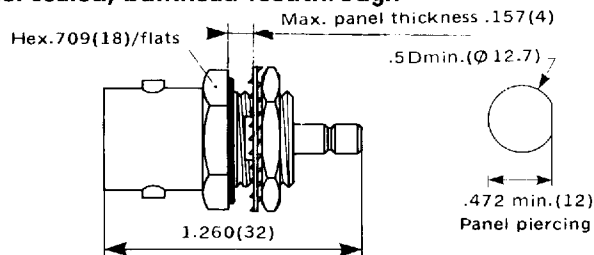
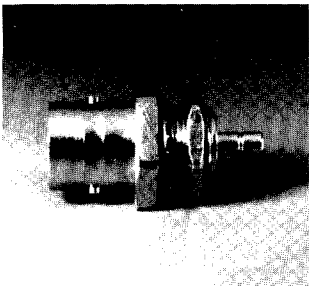

PART NUMBER	R 191 244
-------------	-----------

mQ to BNC/N

mQ JACK to BNC PLUG

PART NUMBER R 191 411

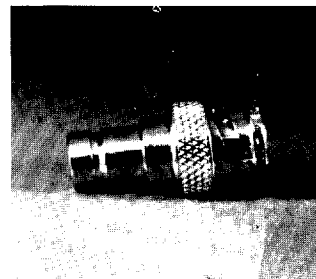
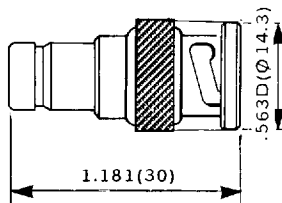

mQ PLUG to BNC JACK

PART NUMBER R 191 413

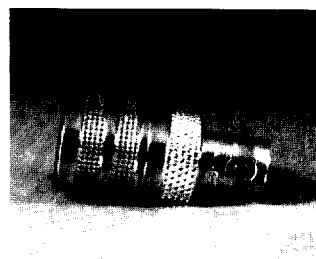
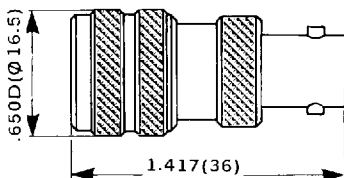

mQ JACK TO BNC JACK

Panel sealed, bulkhead feedthrough

PART NUMBER R 191 416

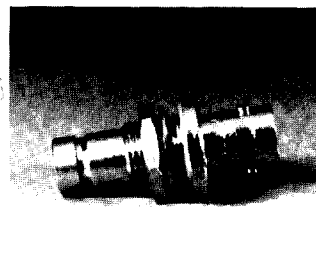
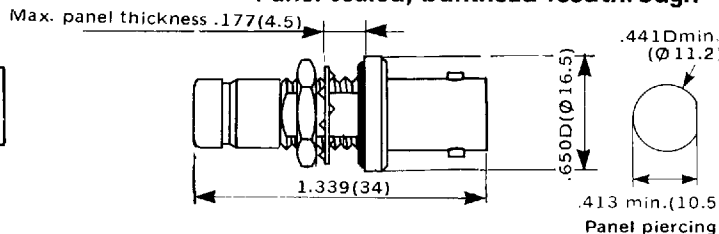

mQ PLUG to N JACK

PART NUMBER R 191 603

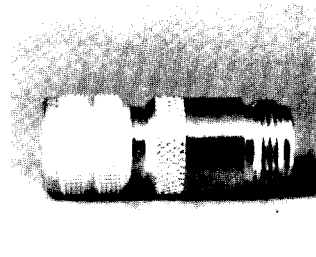
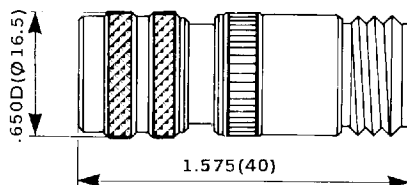

mQ JACK to N PLUG

PART NUMBER R 191 606

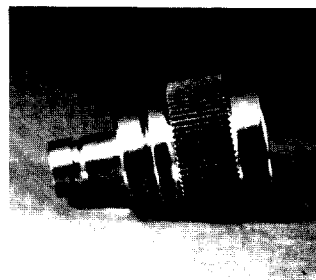
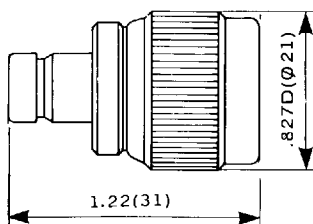

mQ to N

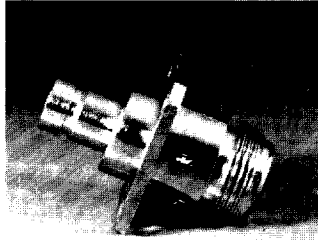

mQ JACK to N JACK
Square flange

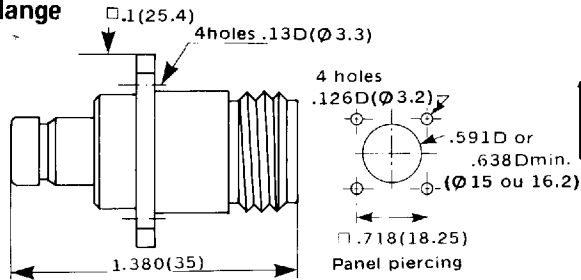

PART NUMBER	R 191 609
-------------	-----------

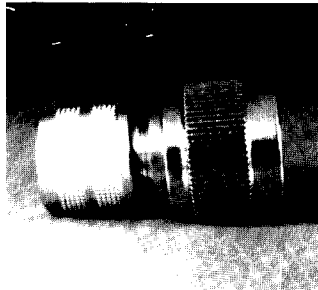

mQ PLUG to N PLUG

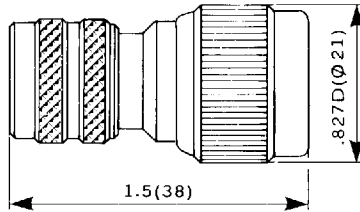

PART NUMBER	R 192 601
Impedance	75 Ω

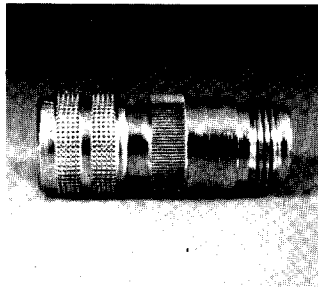

mQ PLUG to N JACK

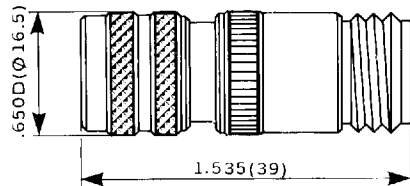

PART NUMBER	R 192 603
Impedance	75 Ω

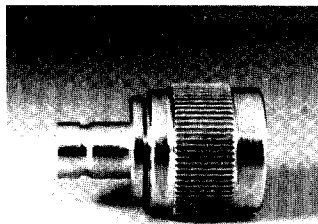

mQ JACK to N PLUG

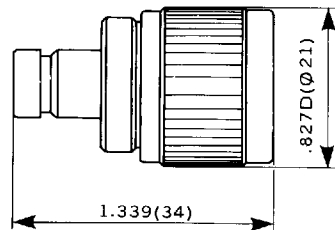

PART NUMBER	R 192 606
Impedance	75 Ω

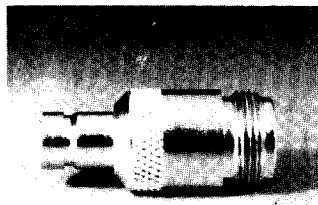

mQ JACK to N JACK

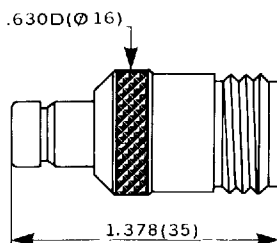

PART NUMBER	R 192 608
Impedance	75 Ω

mQ to 1,6 / 5,6 / UHF / SMB

PART NUMBER	R 192 630
Impedance	75 Ω

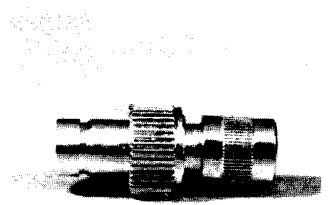
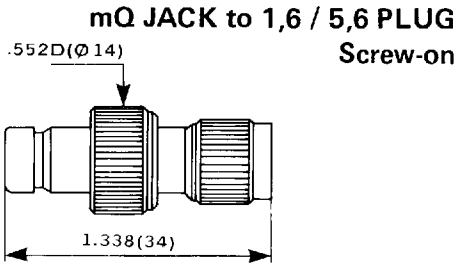

PART NUMBER	R 191 630
-------------	-----------

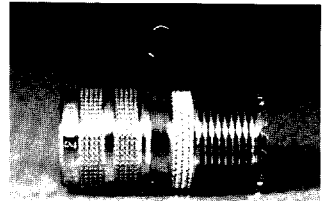
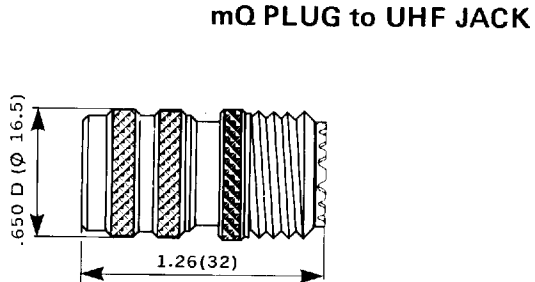

PART NUMBER	R 191 632
-------------	-----------

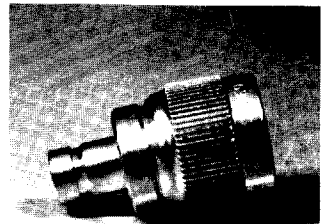
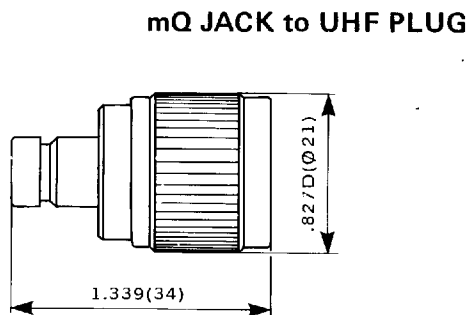

PART NUMBER	R 191 225
-------------	-----------

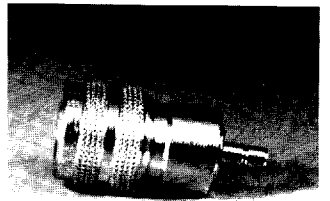
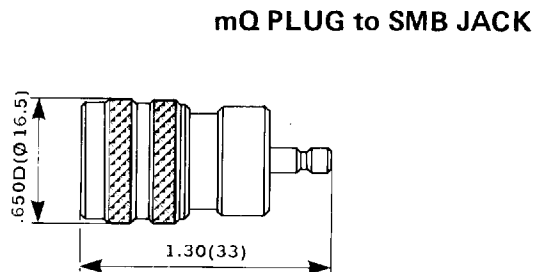

PART NUMBER	R 191 227
-------------	-----------

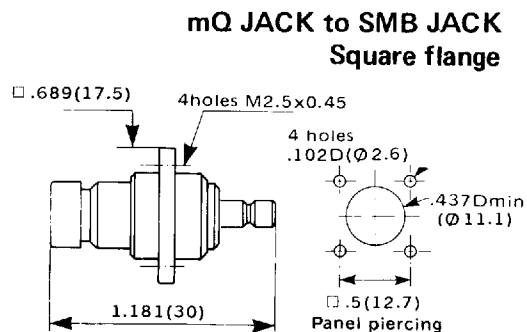

mQ to SMB

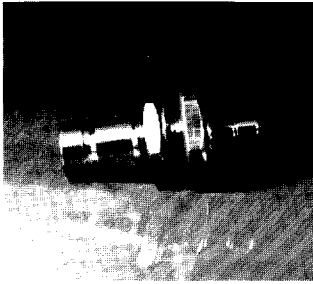

mQ JACK to SMB JACK Panel sealed, bulkhead feedthrough

Max panel thickness .157 (4 max)

Hex. 630(16)flats

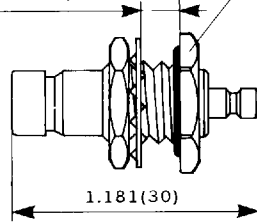

.441Dmin.
(Ø 11.2)

Panel piercing

PART
NUMBER

R 191 228

APC 7

APC 7® to BNC PLUG

PART NUMBER	R 191 013
VSWR	0 - 4 GHz 1.03 + 0.005 F (GHz)

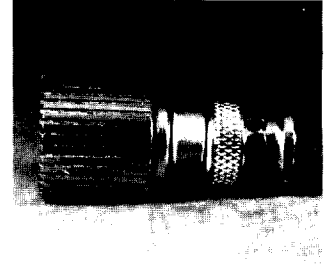
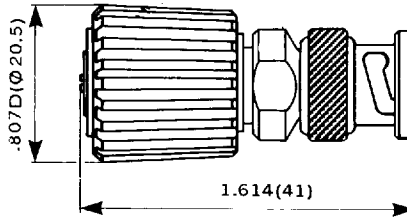

APC 7® to BNC JACK

PART NUMBER	R 191 015
VSWR	0 - 4 GHz 1.03 + 0.005 F (GHz)

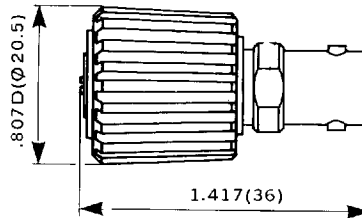

APC 7® to TNC / TNC 18 GHz PLUG

PART NUMBER	R 191 017	R 191 017 700
VSWR	0 - 11 GHz 1.04 + 0.003 F (GHz)	0 - 18 GHz 1.03 + 0.002 F (GHz)
Connector	TNC	TNC 18 GHz

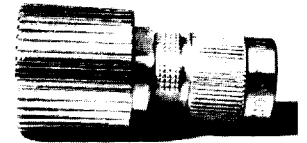
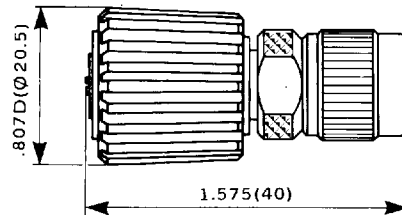

Hexagonal cap for R 191 017 700

APC 7® to TNC / TNC 18 GHz JACK

PART NUMBER	R 191 019	R 191 019 700
VSWR	0 - 11 GHz 1.04 + 0.003 F (GHz)	0 - 18 GHz 1.03 + 0.002 F (GHz)
Connector	TNC	TNC 18 GHz

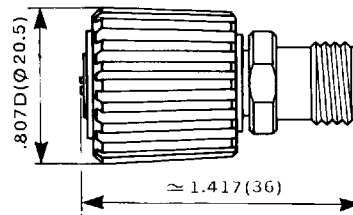

APC 7® to NP PLUG

PART NUMBER	R 191 025
VSWR	0 - 18 GHz 1.03 + 0.002 F (GHz)

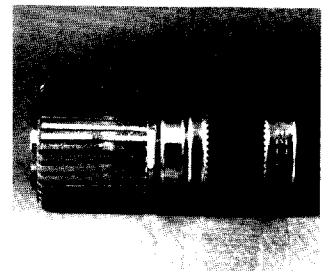
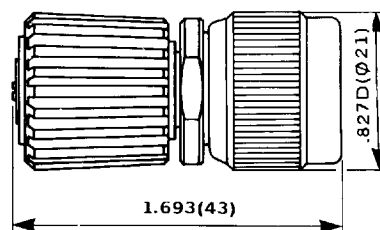

APC 7

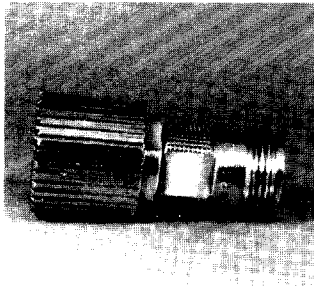

APC 7[®] to N 18 GHz JACK

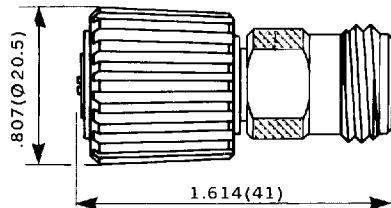

PART NUMBER	R 191 027
VSWR	0 - 18 GHz 1.03 + 0.0015 F (GHz)

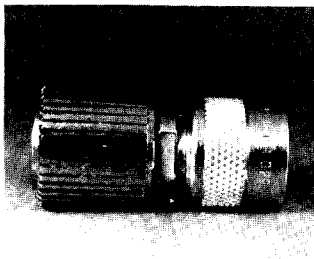

APC 7[®] to C PLUG

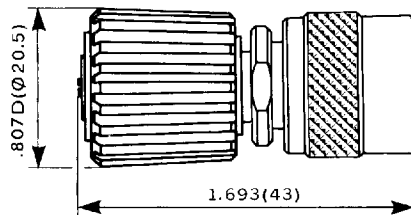

PART NUMBER	R 191 029
VSWR	0 - 11 GHz 1.04 + 0.01 F (GHz)

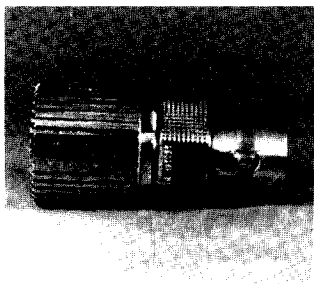

APC 7[®] to C JACK

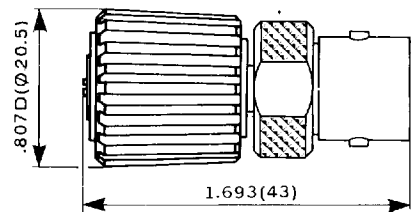

PART NUMBER	R 191 031
VSWR	0 - 11 GHz 1.04 + 0.01 F (GHz)



APC 7[®] - to SMA PLUG

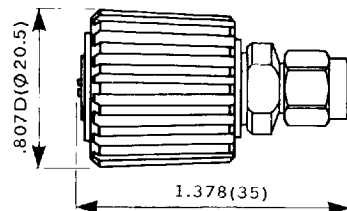

PART NUMBER	R 191 009
VSWR	0 - 18 GHz 1.05 + 0.002 F (GHz)

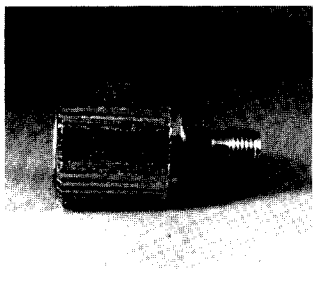

APC 7[®] to SMA JACK

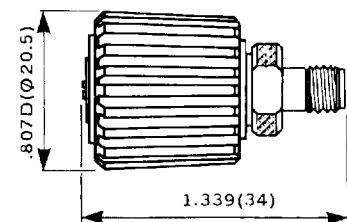

PART NUMBER	R 191 011
VSWR	0 - 18 GHz 1.05 + 0.002 F (GHz)

APC 7[®] to SMA 3.5 PLUG

PART NUMBER	R 191 010
VSWR	0 - 18 GHz 1.03 + 0.003 F (GHz)

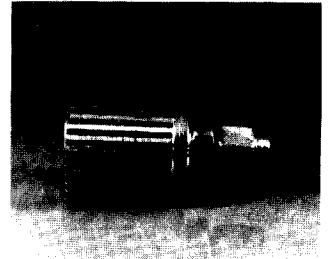
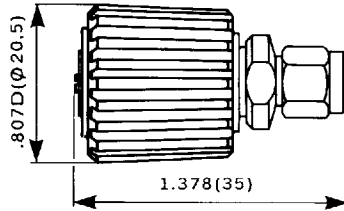

APC 7[®] to SMA 3.5 JACK

PART NUMBER	R 191 012
VSWR	0 - 18 GHz 1.03 + 0.003 F (GHz)

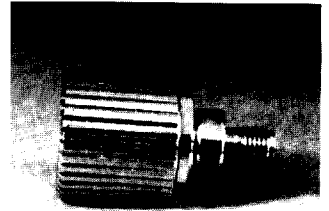
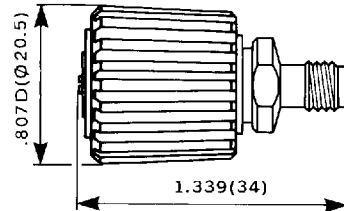

APC 7[®] to SMB JACK

PART NUMBER	R 191 005
VSWR	0 - 4 GHz 1.03 + 0.01 F (GHz)

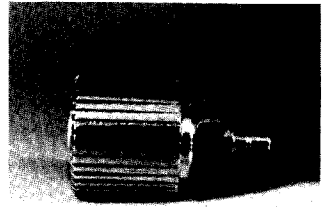
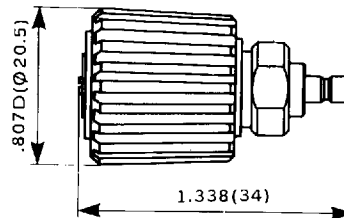

APC 7[®] to SMB PLUG

PART NUMBER	R 191 007
VSWR	0 - 4 GHz 1.03 + 0.01 F (GHz)

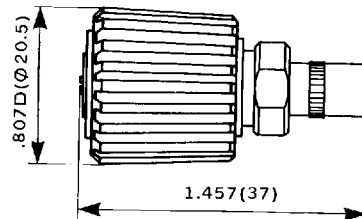

APC 7[®] to SMC JACK

PART NUMBER	R 191 001
VSWR	0 - 11 GHz 1.07 + 0.01 F (GHz)

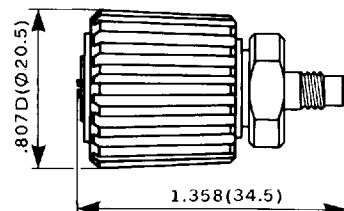

APC 7

APC 7[®] to SMC PLUG

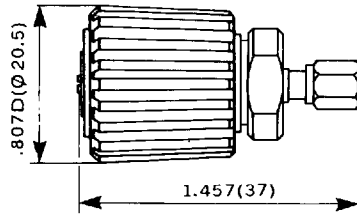
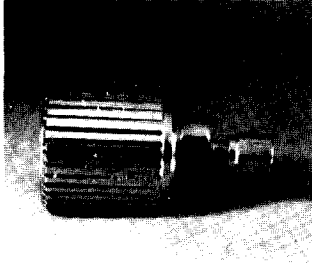

PART NUMBER	R 191 003
VSWR	0 - 11 GHz 1.07 + 0.01 F (GHz)

APC 7[®] to SSMA PLUG

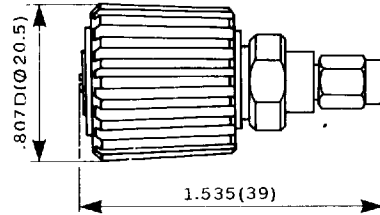
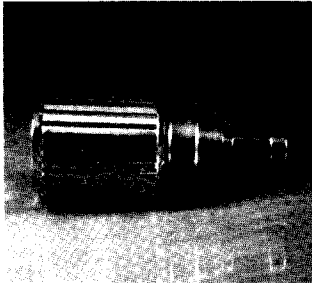

PART NUMBER	R 191 033
VSWR	0 - 18 GHz 1.03 + 0.006 F (GHz)

APC 7[®] to SSMA JACK

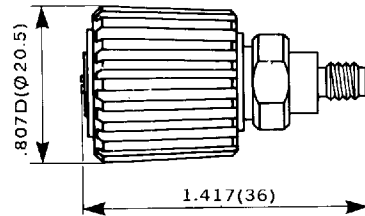
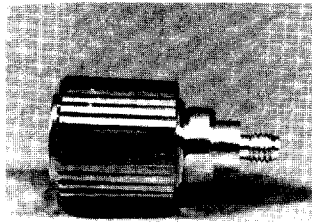

PART NUMBER	R 191 035
VSWR	0 - 18 GHz 1.03 + 0.006 F (GHz)

7 mm N 18 GHz PLUG 7 mm N 18 GHz JACK

— The kit includes 4 sockets and 4 pins



PART NUMBER	R 191 094
VSWR	0 - 18 GHz 1.05 Max.

