



EAO Product Information

Series 18



Index

Series 18

	Description	Page 213
	Product Assembly	Page 214
	Product Range	
	- pushbuttons for standard mounting	Page 215
	- pushbuttons for flush mounting	Page 216
	- accessories / spare parts	Page 217
	Technical Data	Page 219
	Technical Drawing / Dimension / Layout	Page 220
Circuit Drawing	Page 222	

General Notes

The series 18 comprises compact indicators for direct connection to 2.2, 12 or 24 VDC and illuminated pushbuttons with maintained or momentary action.

The illuminated pushbuttons are equipped with a snap-action switching system with normally open or normally closed contacts.

The dimensions of the front are 9 x 14 mm, 9 x 9 mm or 9 mm dia. Indicators and illuminated pushbuttons for use with overhanging lenses 14 x 14 mm or 14 mm dia. are also available for recessed front mounting.

Mounting

Mounting from the front through the mounting aperture 8 mm dia. (15.8 x 15.8 mm resp. 16 mm dia. for recessed versions) is assured even with the wiring already attached (mounting dimensions and spacing see pages 221).

The units are provided with soldering or plug-in terminals.

Lenses

The flat lenses, which are made of PMMA, PS, are available in various colours and a transparent version. The surface is nonreflecting (matt).

Illumination

Perfect illumination of the lenses, which can be supplied in various colours, is assured by bipin T1 LEDs in the colours red, yellow and green.

(Compact indicators for connection to 12 or 24 VDC.)

The bipin T1 LED are already integrated in the lenses.

Position Indication

When a switch with maintained action is actuated, the lens remains in the depressed position mechanically. The state of the switch is apparent at all times from the position of the lens.

Number structure

18-XXX.OX5X

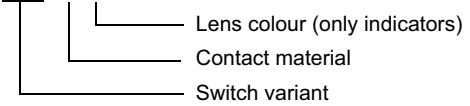

18-9XX.X

Lens

18-9XX.X

Other accessories

Example:

-Illuminated pushbutton; round, momentary action, gold contact; soldering terminals
18-137.035

-Lens red, circular
18-931.2

All dimensions in mm.

We reserve the right to modify technical data.

illuminated-/pushbutton



- 1 lens
- 2 switch housing
- 3 fixing nut

illuminated-/pushbutton, round for flush mounting

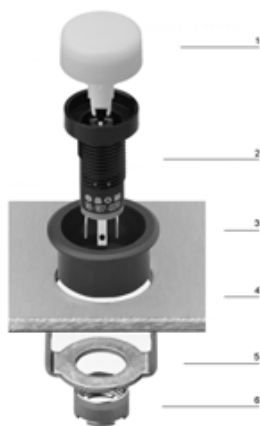

- 1 lens
- 2 switch housing
- 3 front panel
- 4 front bezel bracket
- 5 front bezel bracket
- 6 fixing nut

indicator



indicator	voltage/current	colour of lens	connection method				circuit drawing	technical drawing	mounting dimensions	component layout	
				9 x 14 mm Typ-Nr.	9 x 9 mm Typ-Nr.	9 mm dia. Typ-Nr.					
indicator	12 VDC/20 mA	yellow	S	18-041.0054	18-051.0054	18-031.0054	1	1	1	1	0,002
		green	S	18-041.0055	18-051.0055	18-031.0055	1	1	1	1	0,002
		red	S	18-041.0052	18-051.0052	18-031.0052	1	1	1	1	0,002
	2.2 VDC/20 mA	yellow	S	18-040.0054	18-050.0054	18-030.0054	1	1	1	1	0,002
		green	S	18-040.0055	18-050.0055	18-030.0055	1	1	1	1	0,002
		red	S	18-040.0052	18-050.0052	18-030.0052	1	1	1	1	0,002
	24 VDC/20 mA	yellow	S	18-042.0054	18-052.0054	18-032.0054	1	1	1	1	0,002
		green	S	18-042.0055	18-052.0055	18-032.0055	1	1	1	1	0,002
		red	S	18-042.0052	18-052.0052	18-032.0052	1	1	1	1	0,002

connection method : soldering terminal = S

circuit drawings from page 222, technical drawings from page 220, mounting dimensions from page 221, component layouts from page 221

illuminated-/pushbutton



lens page 217

lens with LED page 217

illuminated-/pushbutton	switching system	contacts	switching action	connection method				circuit drawing	technical drawing	mounting dimensions	component layout	
					9 x 14 mm Typ-Nr.	9 x 9 mm Typ-Nr.	9 mm dia. Typ-Nr.					
illuminated-/pushbutton	SA		M	S	18-147.035	18-157.035	18-137.035	2	2	1	2	0,002
			MA	S	18-247.035	18-257.035	18-237.035	3	2	1	2	0,002
		1 NC	M	S	18-148.035	18-158.035	18-138.035	4	2	1	2	0,002
			MA	S	18-248.035	18-258.035	18-238.035	5	2	1	2	0,002

switching system : snap-action switching element = SA

contacts : 1 normally open = , 1 normally closed = 1 NC

switching action : momentary action = M, maintained action = MA

connection method : soldering terminal = S

circuit drawings from page 222, technical drawings from page 220, mounting dimensions from page 221, component layouts from page 221

indicator for flush mounting



☞ front bezel-set for flush mounting page 218

	voltage/current	colour of lens	connection method	19 x 19 mm Typ-Nr.	19 mm dia. Typ-Nr.	circuit drawing	technical drawing	mounting dimensions	component layout	
indicator for flush mounting	12 VDC/20 mA	yellow	S	18-081.0054	18-061.0054	1	3	2	2	0,003
		green	S	18-081.0055	18-061.0055	1	3	2	2	0,003
		red	S	18-081.0052	18-061.0052	1	3	2	2	0,003
	2.2 VDC/20 mA	yellow	S	18-080.0054	18-060.0054	1	3	2	2	0,002
		green	S	18-080.0055	18-060.0055	1	3	2	2	0,002
		red	S	18-080.0052	18-060.0052	1	3	2	2	0,002
	24 VDC/20 mA	yellow	S	18-082.0054	18-062.0054	1	3	2	2	0,003
		green	S	18-082.0055	18-062.0055	1	3	2	2	0,003
		red	S	18-082.0052	18-062.0052	1	3	2	2	0,003

connection method : soldering terminal = S

circuit drawings from page 222, technical drawings from page 220, mounting dimensions from page 221, component layouts from page 221

illuminated-/pushbutton for flush mounting



☞ lens overhanging page 217

☞ lens overhanging with LED page 217

☞ front bezel-set for flush mounting page 218

	switching system	contacts	switching action	connection method	19 x 19 mm Typ-Nr.	19 mm dia. Typ-Nr.	circuit drawing	technical drawing	mounting dimensions	component layout	
illuminated-/pushbutton for flush mounting	SA	1 NO	M	S	18-187.035	18-167.035	2	4	2	2	0,002
			MA	S	18-287.035	18-267.035	3	4	2	2	0,002
	1 NC	M	S	18-188.035	18-168.035	4	4	2	2	0,002	
		MA	S	18-288.035	18-268.035	5	4	2	2	0,002	

switching system : snap-action switching element = SA

contacts : 1 normally open = , 1 normally closed = 1 NC

switching action : momentary action = M, maintained action = MA

connection method : soldering terminal = S

circuit drawings from page 222, technical drawings from page 220, mounting dimensions from page 221, component layouts from page 221

at front

lens

	shape	lens	colour	∅ 9 x 14 mm Typ-Nr.	∅ 9 x 9 mm Typ-Nr.	9 mm dia. Typ-Nr.	
lens plastic	flat	translucent, matt	yellow	18-942.4	18-952.4	18-932.4	0,001
			grey	18-942.8	18-952.8	18-932.8	0,001
			green	18-942.5	18-952.5	18-932.5	0,001
			red	18-942.2	18-952.2	18-932.2	0,001
			black	18-942.0	18-952.0	18-932.0	0,001
			white	18-942.9	18-952.9	18-932.9	0,001



lens with LED

	shape	lens	colour	∅ 9 x 14 mm Typ-Nr.	∅ 9 x 9 mm Typ-Nr.	9 mm dia. Typ-Nr.	
lens with LED plastic, without built-in series resistor, typ. forward voltage 2.2 VDC/20 mA	flat	translucent, matt	yellow	18-941.4	18-951.4	18-931.4	0,001
			green	18-941.5	18-951.5	18-931.5	0,001
			red	18-941.2	18-951.2	18-931.2	0,001

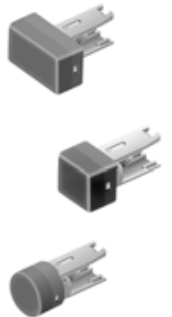

lens overhanging

for flush mounting

	shape	lens	colour	∅ 19 x 19 mm Typ-Nr.	19 mm dia. Typ-Nr.	
lens overhanging plastic	flat	translucent, matt	yellow	18-982.4	18-962.4	0,001
			grey	18-982.8	18-962.8	0,001
			green	18-982.5	18-962.5	0,001
			red	18-982.2	18-962.2	0,001
			black	18-982.0	18-962.0	0,001
			white	18-982.9	18-962.9	0,001



lens overhanging with LED

for flush mounting

	shape	lens	colour	∅ 19 x 19 mm Typ-Nr.	19 mm dia. Typ-Nr.	
lens overhanging with LED plastic, without built-in series resistor, typ. forward voltage 2.2 VDC/20 mA	flat	translucent, matt	yellow	18-981.4	18-961.4	0,001
			green	18-981.5	18-961.5	0,001
			red	18-981.2	18-961.2	0,001



front bezel-set for flush mounting

for overhanging lenses

	material	colour	⌀ 19 x 19 mm Typ-Nr.	19 mm dia. Typ-Nr.	
front bezel-set for flush mounting for lens square	plastic	black	18-920.1		0,006
for lens round	plastic	black	18-920.2	18-920.3	0,006



blind plug

	colour	⌀ 9 x 9 mm Typ-Nr.	9 mm dia. Typ-Nr.	
blind plug	black	19-948.0	19-949.0	0,001



at back

PCB plug-in base

	for	pin orientation	part no.	technical drawing	component layout	
PCB plug-in base	soldering terminal	right-angled	18-946	6	4	0,001
		axial	18-945	5	3	0,001



technical drawings from page 220, component layouts from page 221

assembling

lens remover

	part no.	
lens remover	18-910	0,002



mounting tool

	part no.	
mounting tool for tightening (or loosening) fixing nuts starting torque fixing nut max. 20 Ncm	19-905	0,011



actuator with snap-action switching element

switching system

switching system

The snap-action switching system was designed for switching low powers in electronic circuits.
Single-break snap-action contact.

material

lens

polymethylacrylate PMMA, polycarbonate PC

material of contacts

gold contact on nickel plating

actuator case

polyamide; colour black

mechanical characteristics

connection method

The terminals can be used as soldering terminals.
max.wire diameter: 2 of 0.5 mm &
max.wire cross-section of stranded cable: 1 x 0.75 mm &
wire cross-section of terminal: 1.6 x 0.4 mm

starting torque

for fixing nut max. 20 Ncm

actuating force

1.4 N

storage temperature

-40°C to + 80°C
(as per DIN IEC 68-)

mechanical life

as per IEC 512-5, test 9a
momentary action 2 million cycles of operation
maintained action 1 million cycles of operation

rebound time

<= 2.5 ms

travel

2.2 mm ± 0.2 mm

resistance to shock

(single impacts, semi-sinusoidal)
50 g for 11 ms as per IEC 68-2-27

degree of protection

front as per IEC 529: IP 40

resistance to vibration

(sinusoidal) 10 g at 10-2000 Hz, amplitude 0.75 mm as per IEC 512-4-4

ambient air temperature

-25°C to + 65°C
(as per DIN IEC 68-)

electrical characteristics

contact resistance

<= 100 mΩ starting value (initial)
IEC 512-2, Test 2 b

electrical life

>= 500.000 cycles of operation at 30 VDC/100 mA to IEC 512-5, Test 9c

switch rating

10 μA/100 μV to 100 mA at 42 VAC/VDC

electric strength

500 VAC, 50 Hz, 1 min. between all terminals and earth, as per IEC 512-2-11

power consumption

20 mA

technical drawings

1 indicator page 215

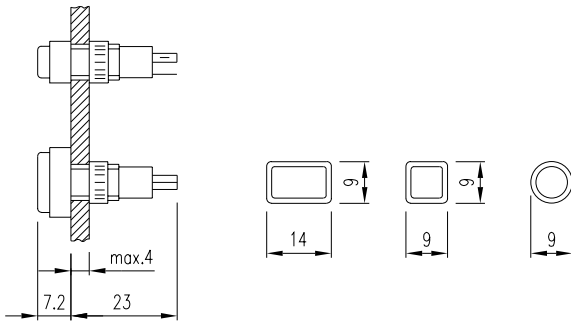

2 illuminated-/pushbutton page 215

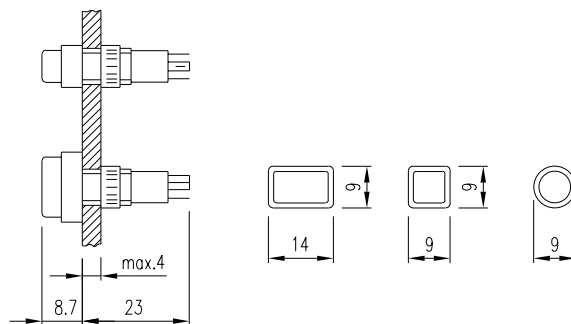

3 indicator for flush mounting page 216

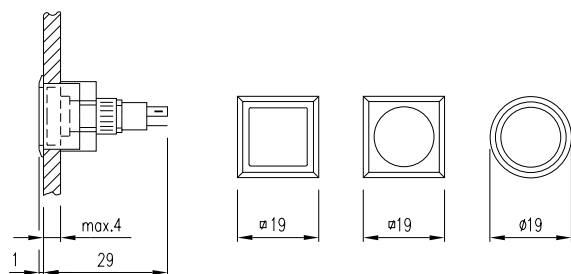

4 illuminated-/pushbutton for flush mounting page 216

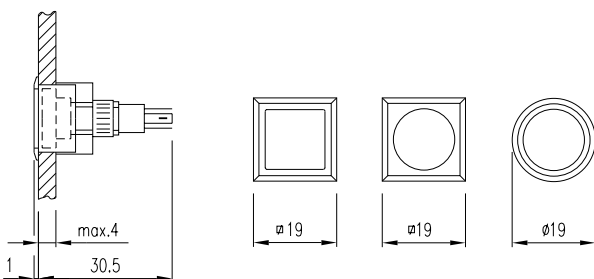

5 PCB plug-in base

page 218

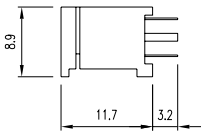

6 PCB plug-in base

page 218

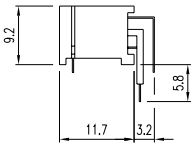

mounting dimensions

1 indicator, illuminated-/pushbutton

page 215, 215

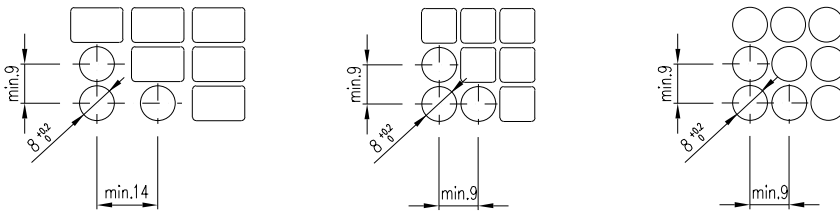

2 indicator for flush mounting, illuminated-/pushbutton for flush mounting

page 216, 216

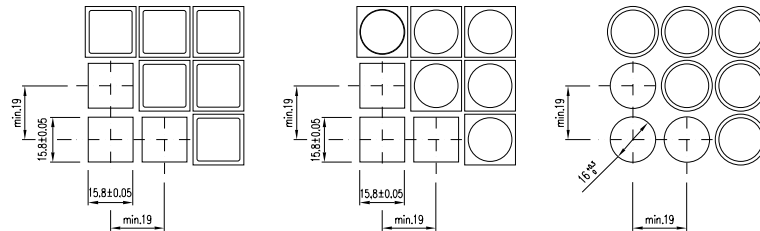

component layouts

1 indicator

page 215

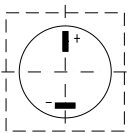

2 illuminated-/pushbutton

page 215

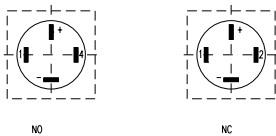

3 PCB plug-in base

page 218

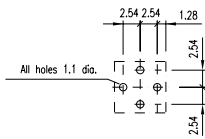

4 PCB plug-in base

page 218

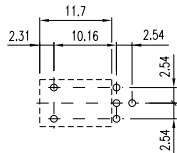

circuit drawings

1 indicator, indicator for flush mounting

page 215, 216



2 illuminated-/pushbutton, illuminated-/pushbutton for flush mounting

page 215, 216

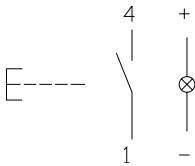

3 illuminated-/pushbutton, illuminated-/pushbutton for flush mounting

page 215, 216

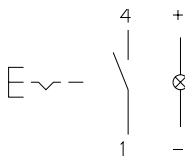

4 illuminated-/pushbutton, illuminated-/pushbutton for flush mounting

page 215, 216

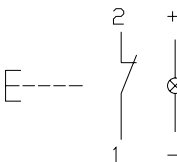

5 illuminated-/pushbutton, illuminated-/pushbutton for flush mounting

page 215, 216

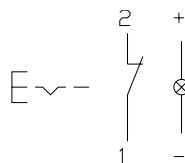

	EAO AG Tannwaldstrasse 88 4601 Olten, Switzerland
E-mail	info@eao.com
Website	www.eao.com
	Belgium
Phone	+32/2 456 00 10
E-mail	sales.ebl@eao.com
	China
Phone	+852/27 86 91 41
E-mail	sales.ehk@eao.com.hk
	France
Phone	+33/1 64 43 37 37
E-mail	sales.es@eao.com
	Germany
Phone	+49/201 85 87 0
E-mail	sales.ede@eao.com
	Japan
Phone	+81/3 5401 0953
E-mail	sales.esj@eao.com
	Netherlands
Phone	+31/78 653 17 00
E-mail	sales.enl@eao.com
	Sweden
Phone	+46/8 683 86 60
E-mail	sales.esw@eao.com
	Switzerland
Phone	+41/62 388 95 00
E-mail	sales.ech@eao.com
	United Kingdom
Phone	+44/1444 236000
E-mail	sales.euk@eao.com
	USA
Phone	+1/203 877 4577
E-mail	sales.eus@eao.com
	Other Countries
Fax	+41/62 296 21 62
E-mail	info@eao.com
Website	www.eao.com