

- **Low Supply Voltage Range 1.8 V to 3.6 V**
- **Ultralow-Power Consumption**
  - Active Mode: 250  $\mu$ A at 1 MHz, 2.2 V
  - Standby Mode: 0.7  $\mu$ A
  - Off Mode (RAM Retention): 0.1  $\mu$ A
- **Ultrafast Wake-Up From Standby Mode in less than 1  $\mu$ s**
- **16-Bit RISC Architecture, 62.5 ns Instruction Cycle Time**
- **Basic Clock Module Configurations:**
  - Internal Frequencies up to 16MHz with 4 calibrated Frequencies to  $\pm 1\%$
  - 32-kHz Crystal
  - High-Frequency Crystal up to 16MHz
  - Resonator
  - External Digital Clock Source
- **16-Bit Timer\_A With Three Capture/Compare Registers**
- **On-Chip Comparator for Analog Signal Compare Function or Slope A/D Conversion**
- **Brownout Detector**
- **Serial Onboard Programming, No External Programming Voltage Needed Programmable Code Protection by Security Fuse**
- **Bootstrap Loader**
- **On Chip Emulation Module**
- **Family Members Include:**
  - MSP430F2101: 1KB + 256B Flash Memory 128B RAM
  - MSP430F2111: 2KB + 256B Flash Memory 128B RAM
  - MSP430F2121: 4KB + 256B Flash Memory 256B RAM
  - MSP430F2131: 8KB + 256B Flash Memory 256B RAM
- **Available in a 20-Pin Plastic Small-Outline Wide Body (SOWB) Package, 20-Pin Plastic Small-Outline Thin (TSSOP) Package, 20-Pin TVSOP and 24-Pin QFN**
- **For Complete Module Descriptions, Refer to the *MSP430x2xx Family User's Guide***

## description

The Texas Instruments MSP430 family of ultralow power microcontrollers consist of several devices featuring different sets of peripherals targeted for various applications. The architecture, combined with five low power modes is optimized to achieve extended battery life in portable measurement applications. The device features a powerful 16-bit RISC CPU, 16-bit registers, and constant generators that attribute to maximum code efficiency. The digitally controlled oscillator (DCO) allows wake-up from low-power modes to active mode in less than 1 $\mu$ s.

The MSP430x21x1 series is an ultralow-power mixed signal microcontroller with a built-in 16-bit timer, versatile analog comparator and sixteen I/O pins.

Typical applications include sensor systems that capture analog signals, convert them to digital values, and then process the data for display or for transmission to a host system. Stand alone RF sensor front end is another area of application. The analog comparator provides slope A/D conversion capability.

### AVAILABLE OPTIONS

T <sub>A</sub>	PACKAGED DEVICES			
	PLASTIC 20-PIN SOWB (DW)	PLASTIC 20-PIN TSSOP (PW)	PLASTIC 20-PIN TVSOP (DGV)	PLASTIC 24-PIN QFN (RGE)
–40°C to 85°C	MSP430F2101IDW MSP430F2111IDW MSP430F2121IDW MSP430F2131IDW	MSP430F2101IPW MSP430F2111IPW MSP430F2121IPW MSP430F2131IPW	MSP430F2101IDGV MSP430F2111IDGV MSP430F2121IDGV MSP430F2131IDGV	MSP430F2101IRGE MSP430F2111IRGE MSP430F2121IRGE MSP430F2131IRGE
–40°C to 105°C	MSP430F2101TDW MSP430F2111TDW MSP430F2121TDW MSP430F2131TDW	MSP430F2101TPW MSP430F2111TPW MSP430F2121TPW MSP430F2131TPW	MSP430F2101TDGV MSP430F2111TDGV MSP430F2121TDGV MSP430F2131TDGV	MSP430F2101TRGE MSP430F2111TRGE MSP430F2121TRGE MSP430F2131TRGE



Please be aware that an important notice concerning availability, standard warranty, and use in critical applications of Texas Instruments semiconductor products and disclaimers thereto appears at the end of this data sheet.

**PRODUCTION DATA** information is current as of publication date. Products conform to specifications per the terms of Texas Instruments standard warranty. Production processing does not necessarily include testing of all parameters.



POST OFFICE BOX 655303 • DALLAS, TEXAS 75265

Copyright © 2004 – 2006 Texas Instruments Incorporated

# MSP430x21x1 MIXED SIGNAL MICROCONTROLLER

SLAS439C – SEPTEMBER 2004 – REVISED JULY 2006

## device pinout

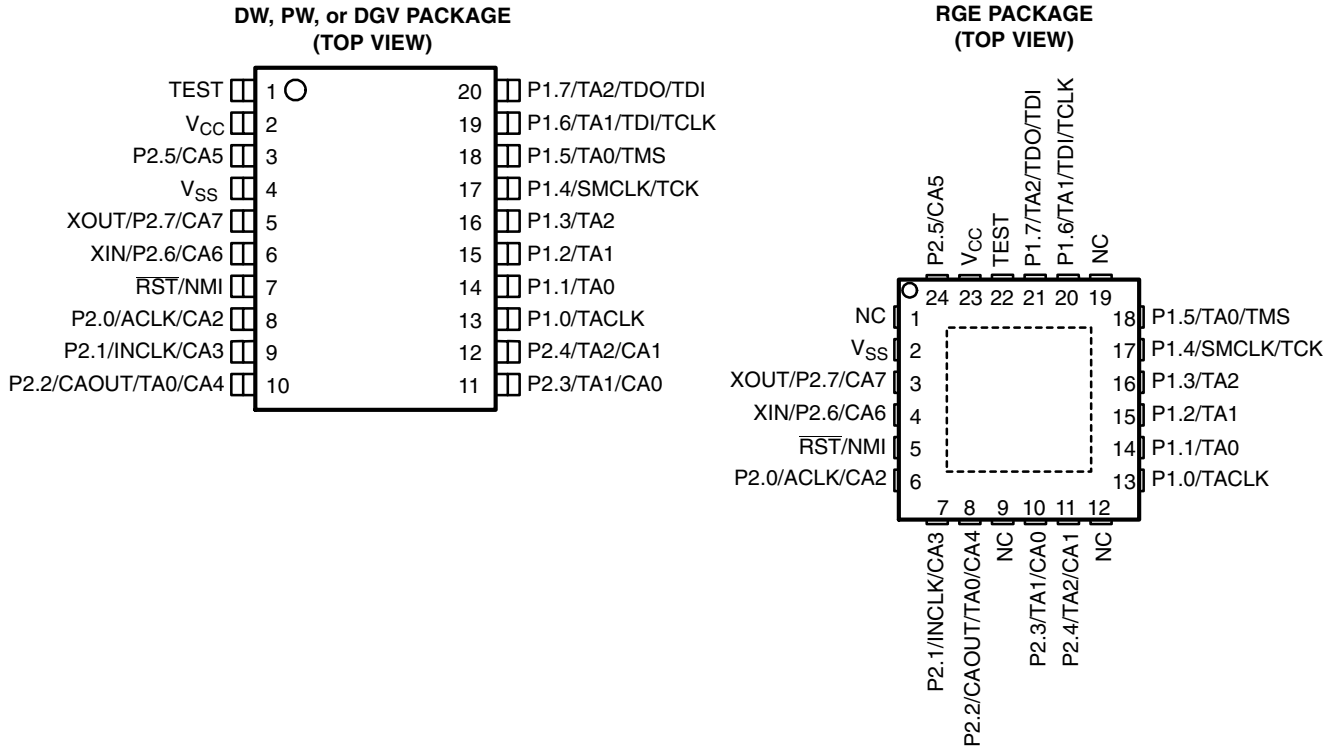

Note: NC pins not internally connected  
Power Pad connection to V<sub>SS</sub> recommended

## functional block diagram

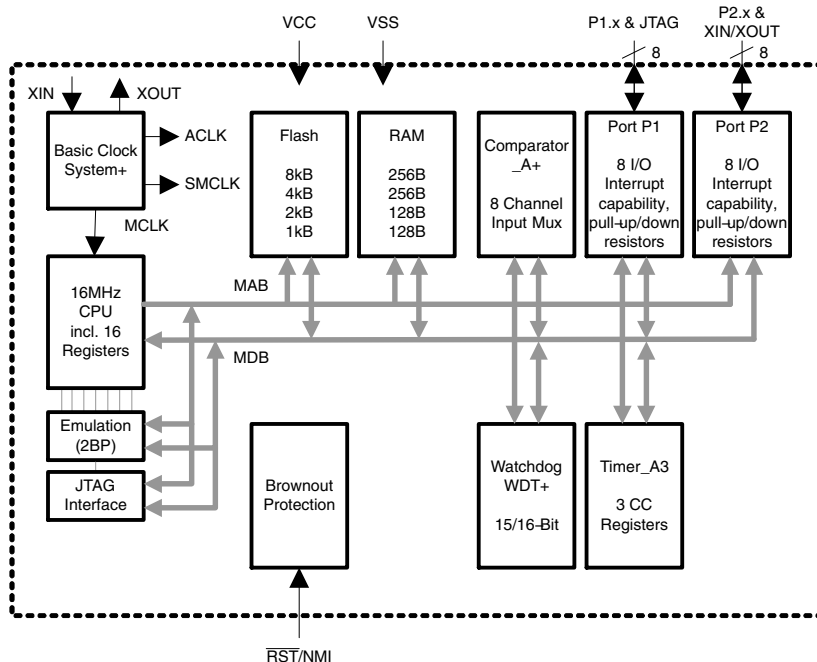

NOTE: See port schematics section for detailed I/O information.

### Terminal Functions

TERMINAL				DESCRIPTION
NAME	DW, PW, or DGV NO.	RGE NO.	I/O	
P1.0/TACLK	13	13	I/O	General-purpose digital I/O pin Timer_A, clock signal TACLK input
P1.1/TA0	14	14	I/O	General-purpose digital I/O pin Timer_A, capture: CC10A input, compare: Out0 output/BSL transmit
P1.2/TA1	15	15	I/O	General-purpose digital I/O pin Timer_A, capture: CC11A input, compare: Out1 output
P1.3/TA2	16	16	I/O	General-purpose digital I/O pin Timer_A, capture: CC12A input, compare: Out2 output
P1.4/SMCLK/TCK	17	17	I/O	General-purpose digital I/O pin / SMCLK signal output Test Clock input for device programming and test
P1.5/TA0/TMS	18	18	I/O	General-purpose digital I/O pin / Timer_A, compare: Out0 output Test Mode Select input for device programming and test
P1.6/TA1/TDI/TCLK	19	20	I/O	General-purpose digital I/O pin / Timer_A, compare: Out1 output Test Data Input or Test Clock Input for programming and test
P1.7/TA2/TDO/TDI†	20	21	I/O	General-purpose digital I/O pin / Timer_A, compare: Out2 output Test Data Output or Test Data Input for programming and test
P2.0/ACLK/CA2	8	6	I/O	General-purpose digital I/O pin / ACLK output Comparator_A+, CA2 input
P2.1/INCLK/CA3	9	7	I/O	General-purpose digital I/O pin / Timer_A, clock signal at INCLK Comparator_A+, CA3 input
P2.2/CAOUT/TA0/CA4	10	8	I/O	General-purpose digital I/O pin Timer_A, capture: CC10B input/BSL receive Comparator_A+, output / CA4 input
P2.3/CA0/TA1	11	10	I/O	General-purpose digital I/O pin / Timer_A, compare: Out1 output Comparator_A+, CA0 input
P2.4/CA1/TA2	12	11	I/O	General-purpose digital I/O pin / Timer_A, compare: Out2 output Comparator_A+, CA1 input
P2.5/CA5	3	24	I/O	General-purpose digital I/O pin Comparator_A+, CA5 input
XIN/P2.6/CA6	6	4	I/O	Input terminal of crystal oscillator General-purpose digital I/O pin Comparator_A+, CA6 input
XOUT/P2.7/CA7	5	3	I/O	Output terminal of crystal oscillator general-purpose digital I/O pin Comparator_A+, CA7 input
RST/NMI	7	5	I	Reset or nonmaskable interrupt input
TEST	1	22	I	Selects test mode for JTAG pins on Port1. The device protection fuse is connected to TEST.
V <sub>CC</sub>	2	23		Supply voltage
V <sub>SS</sub>	4	2		Ground reference
QFN Pad	NA	Package Pad	NA	QFN package pad connection to V <sub>SS</sub> recommended.

† TDO or TDI is selected via JTAG instruction.

NOTE: If XOUT/P2.7/CA7 is used as an input, excess current will flow until P2SEL.7 is cleared. This is due to the oscillator output driver connection to this pad after reset.

# MSP430x21x1 MIXED SIGNAL MICROCONTROLLER

SLAS439C – SEPTEMBER 2004 – REVISED JULY 2006

## short-form description

### CPU

The MSP430 CPU has a 16-bit RISC architecture that is highly transparent to the application. All operations, other than program-flow instructions, are performed as register operations in conjunction with seven addressing modes for source operand and four addressing modes for destination operand.

The CPU is integrated with 16 registers that provide reduced instruction execution time. The register-to-register operation execution time is one cycle of the CPU clock.

Four of the registers, R0 to R3, are dedicated as program counter, stack pointer, status register, and constant generator respectively. The remaining registers are general-purpose registers.

Peripherals are connected to the CPU using data, address, and control buses, and can be handled with all instructions.

### instruction set

The instruction set consists of 51 instructions with three formats and seven address modes. Each instruction can operate on word and byte data. Table 1 shows examples of the three types of instruction formats; the address modes are listed in Table 2.

Program Counter	PC/R0
Stack Pointer	SP/R1
Status Register	SR/CG1/R2
Constant Generator	CG2/R3
General-Purpose Register	R4
General-Purpose Register	R5
General-Purpose Register	R6
General-Purpose Register	R7
General-Purpose Register	R8
General-Purpose Register	R9
General-Purpose Register	R10
General-Purpose Register	R11
General-Purpose Register	R12
General-Purpose Register	R13
General-Purpose Register	R14
General-Purpose Register	R15

**Table 1. Instruction Word Formats**

Dual operands, source-destination	e.g. ADD R4,R5	R4 + R5 ----> R5
Single operands, destination only	e.g. CALL R8	PC -->(TOS), R8--> PC
Relative jump, un/conditional	e.g. JNE	Jump-on-equal bit = 0

**Table 2. Address Mode Descriptions**

ADDRESS MODE	S	D	SYNTAX	EXAMPLE	OPERATION
Register	●	●	MOV Rs,Rd	MOV R10,R11	R10 --> R11
Indexed	●	●	MOV X(Rn),Y(Rm)	MOV 2(R5),6(R6)	M(2+R5)--> M(6+R6)
Symbolic (PC relative)	●	●	MOV EDE,TONI		M(EDE) --> M(TONI)
Absolute	●	●	MOV &MEM,&TCDAT		M(MEM) --> M(TCDAT)
Indirect	●		MOV @Rn,Y(Rm)	MOV @R10,Tab(R6)	M(R10) --> M(Tab+R6)
Indirect autoincrement	●		MOV @Rn+,Rm	MOV @R10+,R11	M(R10) --> R11 R10 + 2--> R10
Immediate	●		MOV #X,TONI	MOV #45,TONI	#45 --> M(TONI)

NOTE: S = source D = destination



POST OFFICE BOX 655303 • DALLAS, TEXAS 75265

## operating modes

The MSP430 has one active mode and five software selectable low-power modes of operation. An interrupt event can wake up the device from any of the five low-power modes, service the request and restore back to the low-power mode on return from the interrupt program.

The following six operating modes can be configured by software:

- Active mode AM;
  - All clocks are active
- Low-power mode 0 (LPM0);
  - CPU is disabled  
ACLK and SMCLK remain active. MCLK is disabled
- Low-power mode 1 (LPM1);
  - CPU is disabled  
ACLK and SMCLK remain active. MCLK is disabled  
DCO's dc-generator is disabled if DCO not used in active mode
- Low-power mode 2 (LPM2);
  - CPU is disabled  
MCLK and SMCLK are disabled  
DCO's dc-generator remains enabled  
ACLK remains active
- Low-power mode 3 (LPM3);
  - CPU is disabled  
MCLK and SMCLK are disabled  
DCO's dc-generator is disabled  
ACLK remains active
- Low-power mode 4 (LPM4);
  - CPU is disabled  
ACLK is disabled  
MCLK and SMCLK are disabled  
DCO's dc-generator is disabled  
Crystal oscillator is stopped

# MSP430x21x1 MIXED SIGNAL MICROCONTROLLER

SLAS439C – SEPTEMBER 2004 – REVISED JULY 2006

## interrupt vector addresses

The interrupt vectors and the power-up starting address are located in the address range of 0FFFFh–0FFC0h. The vector contains the 16-bit address of the appropriate interrupt handler instruction sequence.

If the reset vector (located at address 0FFFEh) contains 0FFFFh (e.g. flash is not programmed) the CPU will go into LPM4 immediately after power-up.

INTERRUPT SOURCE	INTERRUPT FLAG	SYSTEM INTERRUPT	WORD ADDRESS	PRIORITY
Power-up External reset Watchdog Flash key violation PC out-of-range (see Note 1)	PORIFG RSTIFG WDTIFG KEYV (see Note 2)	Reset	0FFFEh	31, highest
NMI Oscillator fault Flash memory access violation	NMIIFG OFIFG ACCVIFG (see Notes 2 & 4)	(non)-maskable, (non)-maskable, (non)-maskable	0FFFCh	30
			0FFFAh	29
			0FFF8h	28
Comparator_A+	CAIFG	maskable	0FFF6h	27
Watchdog Timer+	WDTIFG	maskable	0FFF4h	26
Timer_A2	TACCR0 CCIFG (see Note 3)	maskable	0FFF2h	25
Timer_A2	TACCR1 CCIFG, TAIFG (see Notes 2 & 3)	maskable	0FFF0h	24
			0FFEEh	23
			0FFECCh	22
			0FFEAh	21
			0FFE8h	20
I/O Port P2 (eight flags)	P2IFG.0 to P2IFG.7 (see Notes 2 & 3)	maskable	0FFE6h	19
I/O Port P1 (eight flags)	P1IFG.0 to P1IFG.7 (see Notes 2 & 3)	maskable	0FFE4h	18
			0FFE2h	17
			0FFE0h	16
(see Note 5)			0FFDEh	15
(see Note 6)			0FFDCh ... 0FFC0h	14 ... 0, lowest

- NOTES: 1. A reset is generated if the CPU tries to fetch instructions from within the module register memory address range (0h–01FFh).  
 2. Multiple source flags  
 3. Interrupt flags are located in the module  
 4. (non)-maskable: the individual interrupt-enable bit can disable an interrupt event, but the general interrupt enable cannot.  
 5. This location is used as bootstrap loader security key (BSLSKEY).  
 A value of 0AA55h at this location disables the BSL completely.  
 A value of 0h disables the erasure of the flash if an invalid password is supplied.  
 6. The interrupt vectors at addresses 0FFDCh to 0FFC0h are not used in this device and can be used for regular program code if necessary.



## special function registers

Most interrupt and module enable bits are collected into the lowest address space. Special function register bits not allocated to a functional purpose are not physically present in the device. Simple software access is provided with this arrangement.

### interrupt enable 1 and 2

Address	7	6	5	4	3	2	1	0
0h			ACCVIE	NMIIE			OFIE	WDTIE
			rw-0	rw-0			rw-0	rw-0

- WDTIE: Watchdog Timer interrupt enable. Inactive if watchdog mode is selected. Active if Watchdog Timer is configured in interval timer mode.
- OFIE: Oscillator fault enable
- NMIIE: (Non)maskable interrupt enable
- ACCVIE: Flash access violation interrupt enable

Address	7	6	5	4	3	2	1	0
01h								

### interrupt flag register 1 and 2

Address	7	6	5	4	3	2	1	0
02h				NMIIFG	RSTIFG	PORIFG	OFIFG	WDTIFG
				rw-0	rw-(0)	rw-(1)	rw-1	rw-(0)

- WDTIFG: Set on Watchdog Timer overflow (in watchdog mode) or security key violation. Reset on  $V_{CC}$  power-up or a reset condition at  $\overline{RST/NMI}$  pin in reset mode.
- OFIFG: Flag set on oscillator fault
- RSTIFG: External reset interrupt flag. Set on a reset condition at  $\overline{RST/NMI}$  pin in reset mode. Reset on  $V_{CC}$  power-up
- PORIFG: Power-On Reset interrupt flag. Set on  $V_{CC}$  power-up.
- NMIIFG: Set via  $\overline{RST/NMI}$ -pin

Address	7	6	5	4	3	2	1	0
03h								

<b>Legend</b>	<b>rw:</b> Bit can be read and written.
	<b>rw-0,1:</b> Bit can be read and written. It is Reset or Set by PUC.
	<b>rw-(0,1):</b> Bit can be read and written. It is Reset or Set by POR.
<div style="border: 1px solid black; width: 30px; height: 15px; display: inline-block;"></div>	SFR bit is not present in device

# MSP430x21x1 MIXED SIGNAL MICROCONTROLLER

SLAS439C – SEPTEMBER 2004 – REVISED JULY 2006

## memory organization

		MSP430F2101	MSP430F2111	MSP430F2121	MSP430F2131
Memory	Size	1KB Flash	2KB Flash	4KB Flash	8KB Flash
Main: interrupt vector	Flash	0FFFFh–0FFE0h	0FFFFh–0FFE0h	0FFFFh–0FFE0h	0FFFFh–0FFE0h
Main: code memory	Flash	0FFFFh–0FC00h	0FFFFh–0F800h	0FFFFh–0F000h	0FFFFh–0E000h
Information memory	Size	256 Byte	256 Byte	256 Byte	256 Byte
	Flash	010FFh – 01000h	010FFh – 01000h	010FFh – 01000h	010FFh – 01000h
Boot memory	Size	1KB	1KB	1KB	1KB
	ROM	0FFFh – 0C00h	0FFFh – 0C00h	0FFFh – 0C00h	0FFFh – 0C00h
RAM	Size	128 Byte	128 Byte	256 Byte	256 Byte
		027Fh – 0200h	027Fh – 0200h	02FFh – 0200h	02FFh – 0200h
Peripherals	16-bit	01FFh – 0100h	01FFh – 0100h	01FFh – 0100h	01FFh – 0100h
	8-bit	0FFh – 010h	0FFh – 010h	0FFh – 010h	0FFh – 010h
	8-bit SFR	0Fh – 00h	0Fh – 00h	0Fh – 00h	0Fh – 00h

## bootstrap loader (BSL)

The MSP430 bootstrap loader (BSL) enables users to program the flash memory or RAM using a UART serial interface. Access to the MSP430 memory via the BSL is protected by user-defined password. A bootstrap loader security key is provided at address 0FFDEh to disable the BSL completely or to disable the erasure of the flash if an invalid password is supplied. For complete description of the features of the BSL and its implementation, see the Application report *Features of the MSP430 Bootstrap Loader*, Literature Number SLAA089.

BSLKEY	Description
00000h	Erase of flash disabled if an invalid password is supplied
0AA55h	BSL disabled
any other value	BSL enabled

BSL Function	DW, PW & DGV Package Pins	RGE Package Pins
Data Transmit	14 - P1.1	14 - P1.1
Data Receive	10 - P2.2	8 - P2.2

## flash memory

The flash memory can be programmed via the JTAG port, the bootstrap loader, or in-system by the CPU. The CPU can perform single-byte and single-word writes to the flash memory. Features of the flash memory include:

- Flash memory has n segments of main memory and four segments of information memory (A to D) of 64 bytes each. Each segment in main memory is 512 bytes in size.
- Segments 0 to n may be erased in one step, or each segment may be individually erased.
- Segments A to D can be erased individually, or as a group with segments 0–n. Segments A to D are also called *information memory*.
- Segment A contains calibration data. After reset segment A is protected against programming or erasing. It can be unlocked but care should be taken not to erase this segment if the calibration data is required.



## peripherals

Peripherals are connected to the CPU through data, address, and control busses and can be handled using all instructions. For complete module descriptions, refer to the *MSP430x2xx Family User's Guide*.

## oscillator and system clock

The clock system is supported by the basic clock module that includes support for a 32768-Hz watch crystal oscillator, an internal digitally-controlled oscillator (DCO) and a high frequency crystal oscillator. The basic clock module is designed to meet the requirements of both low system cost and low-power consumption. The internal DCO provides a fast turn-on clock source and stabilizes in less than 1  $\mu$ s. The basic clock module provides the following clock signals:

- Auxiliary clock (ACLK), sourced from a 32768-Hz watch crystal or a high frequency crystal.
- Main clock (MCLK), the system clock used by the CPU.
- Sub-Main clock (SMCLK), the sub-system clock used by the peripheral modules.

DCO Calibration Data (provided from factory in flash info memory segment A)			
DCO Frequency	Calibration Register	Size	Address
1 MHz	CALBC1_1MHZ	byte	010FFh
	CALDCO_1MHZ	byte	010FEh
8 MHz	CALBC1_8MHZ	byte	010FDh
	CALDCO_8MHZ	byte	010FCh
12 MHz	CALBC1_12MHZ	byte	010FBh
	CALDCO_12MHZ	byte	010FAh
16 MHz	CALBC1_16MHZ	byte	010F9h
	CALDCO_16MHZ	byte	010F8h

## brownout

The brownout circuit is implemented to provide the proper internal reset signal to the device during power on and power off.

## digital I/O

There are two 8-bit I/O ports implemented—ports P1 and P2:

- All individual I/O bits are independently programmable.
- Any combination of input, output, and interrupt conditions is possible.
- Edge-selectable interrupt input capability for all the eight bits of port P1 and P2.
- Read/write access to port-control registers is supported by all instructions.
- Each I/O has an individually programmable pull-up/pull-down resistor.

## WDT+ watchdog timer

The primary function of the watchdog timer (WDT+) module is to perform a controlled system restart after a software problem occurs. If the selected time interval expires, a system reset is generated. If the watchdog function is not needed in an application, the module can be configured as an interval timer and can generate interrupts at selected time intervals.

# MSP430x21x1 MIXED SIGNAL MICROCONTROLLER

SLAS439C – SEPTEMBER 2004 – REVISED JULY 2006

## comparator\_A+

The primary function of the Comparator\_A+ module is to support precision slope analog-to-digital conversions, battery-voltage supervision, and monitoring of external analog signals.

## timer\_A3

Timer\_A3 is a 16-bit timer/counter with three capture/compare registers. Timer\_A3 can support multiple capture/compares, PWM outputs, and interval timing. Timer\_A3 also has extensive interrupt capabilities. Interrupts may be generated from the counter on overflow conditions and from each of the capture/compare registers.

Timer_A3 Signal Connections							
Input Pin Number		Device Input Signal	Module Input Name	Module Block	Module Output Signal	Output Pin Number	
DW, PW, DGV	RGE					DW, PW, DGV	RGE
13 - P1.0	13 - P1.0	TACLK	TACLK	Timer	NA		
		ACLK	ACLK				
		SMCLK	SMCLK				
9 - P2.1	7 - P2.1	INCLK	INCLK				
14 - P1.1	14 - P1.1	TA0	CCI0A	CCR0	TA0	14 - P1.1	14 - P1.1
10 - P2.2	8 - P2.2	TA0	CCI0B			18 - P1.5	18 - P1.5
		V <sub>SS</sub>	GND				
		V <sub>CC</sub>	V <sub>CC</sub>				
15 - P1.2	15 - P1.2	TA1	CCI1A	CCR1	TA1	11 - P2.3	10 - P2.3
		CAOUT (internal)	CCI1B			15 - P1.2	15 - P1.2
		V <sub>SS</sub>	GND			19 - P1.6	20 - P1.6
		V <sub>CC</sub>	V <sub>CC</sub>				
16 - P1.3	16 - P1.3	TA2	CCI2A	CCR2	TA2	12 - P2.4	11 - P2.4
		ACLK (internal)	CCI2B			16 - P1.3	16 - P1.3
		V <sub>SS</sub>	GND			20 - P1.7	21 - P1.7
		V <sub>CC</sub>	V <sub>CC</sub>				

**peripheral file map**

<b>PERIPHERALS WITH WORD ACCESS</b>			
<b>Timer_A</b>	Capture/compare register	TACCR2	0176h
	Capture/compare register	TACCR1	0174h
	Capture/compare register	TACCR0	0172h
	Timer_A register	TAR	0170h
	Capture/compare control	TACCTL2	0166h
	Capture/compare control	TACCTL1	0164h
	Capture/compare control	TACCTL0	0162h
	Timer_A control	TACTL	0160h
	Timer_A interrupt vector	TAIV	012Eh
<b>Flash Memory</b>	Flash control 3	FCTL3	012Ch
	Flash control 2	FCTL2	012Ah
	Flash control 1	FCTL1	0128h
<b>Watchdog Timer+</b>	Watchdog/timer control	WDTCTL	0120h
<b>PERIPHERALS WITH BYTE ACCESS</b>			
<b>Comparator_A+</b>	Comparator_A+ port disable	CAPD	05Bh
	Comparator_A+ control 2	CACTL2	05Ah
	Comparator_A+ control 1	CACTL1	059h
<b>Basic Clock</b>	Basic clock system control 3	BCSCTL3	053h
	Basic clock system control 2	BCSCTL2	058h
	Basic clock system control 1	BCSCTL1	057h
	DCO clock frequency control	DCOCTL	056h
<b>Port P2</b>	Port P2 resistor enable	P2REN	02Fh
	Port P2 selection	P2SEL	02Eh
	Port P2 interrupt enable	P2IE	02Dh
	Port P2 interrupt edge select	P2IES	02Ch
	Port P2 interrupt flag	P2IFG	02Bh
	Port P2 direction	P2DIR	02Ah
	Port P2 output	P2OUT	029h
	Port P2 input	P2IN	028h
<b>Port P1</b>	Port P1 resistor enable	P1REN	027h
	Port P1 selection	P1SEL	026h
	Port P1 interrupt enable	P1IE	025h
	Port P1 interrupt edge select	P1IES	024h
	Port P1 interrupt flag	P1IFG	023h
	Port P1 direction	P1DIR	022h
	Port P1 output	P1OUT	021h
	Port P1 input	P1IN	020h
<b>Special Function</b>	SFR interrupt flag 2	IFG2	003h
	SFR interrupt flag 1	IFG1	002h
	SFR interrupt enable 2	IE2	001h
	SFR interrupt enable 1	IE1	000h

# MSP430x21x1 MIXED SIGNAL MICROCONTROLLER

SLAS439C – SEPTEMBER 2004 – REVISED JULY 2006

## absolute maximum ratings (see Note 1)

Voltage applied at $V_{CC}$ to $V_{SS}$ .....	-0.3 V to 4.1 V
Voltage applied to any pin (see Note 2) .....	-0.3 V to $V_{CC}+0.3$ V
Diode current at any device terminal .....	$\pm 2$ mA
Storage temperature, $T_{stg}$ (unprogrammed device, see Note 3) .....	-55°C to 150°C
Storage temperature, $T_{stg}$ (programmed device, see Note 3) .....	-40°C to 85°C

- NOTES: 1. Stresses beyond those listed under “absolute maximum ratings” may cause permanent damage to the device. These are stress ratings only, and functional operation of the device at these or any other conditions beyond those indicated under “recommended operating conditions” is not implied. Exposure to absolute-maximum-rated conditions for extended periods may affect device reliability.
2. All voltages referenced to  $V_{SS}$ . The JTAG fuse-blow voltage,  $V_{FB}$ , is allowed to exceed the absolute maximum rating. The voltage is applied to the TEST pin when blowing the JTAG fuse.
3. Higher temperature may be applied during board soldering process according to the current JEDEC J-STD-020 specification with peak reflow temperatures not higher than classified on the device label on the shipping boxes or reels.

## recommended operating conditions

		MIN	NOM	MAX	UNIT
Supply voltage during program execution, $V_{CC}$		1.8		3.6	V
Supply voltage during program/erase flash memory, $V_{CC}$		2.2		3.6	V
Supply voltage, $V_{SS}$			0		V
Operating free-air temperature range, $T_A$	I Version	-40		85	°C
	T Version	-40		105	°C
Processor frequency $f_{SYSTEM}$ (Maximum MCLK frequency) (see Notes 1, 2 and Figure 1)	$V_{CC} = 1.8$ V, Duty Cycle = 50% $\pm 10\%$	0		6	MHz
	$V_{CC} = 2.7$ V, Duty Cycle = 50% $\pm 10\%$ (see Note 3)	0		12	
	$V_{CC} = 3.3$ V, Duty Cycle = 50% $\pm 10\%$ (see Note 4)	0		16	

- NOTES: 1. The MSP430 CPU is clocked directly with MCLK. Both the high and low phase of MCLK must not exceed the pulse width of the specified maximum frequency.
2. Modules might have a different maximum input clock specification. Refer to the specification of the respective module in this datasheet.
3. This includes using the provided DCO calibration value for 12 MHz for  $V_{CC} = 2.7$  V to 3.6 V over the operating temperature range.
4. This includes using the provided DCO calibration value for 16 MHz for  $V_{CC} = 3.3$  V to 3.6 V over the operating temperature range.

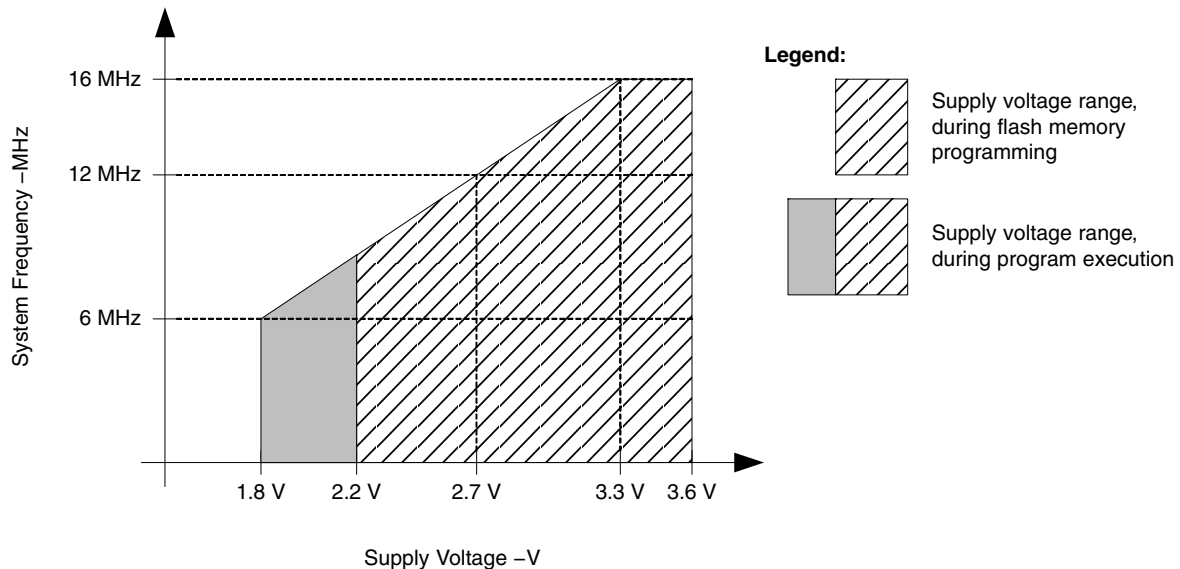

NOTE: Minimum processor frequency is defined by system clock. Flash program or erase operations require a minimum  $V_{CC}$  of 2.2 V.

**Figure 1. Operating Area**



**electrical characteristics over recommended ranges of supply voltage and operating free-air temperature (unless otherwise noted)**

**active mode supply current (into  $V_{CC}$ ) excluding external current (see Notes 1 and 2)**

PARAMETER	TEST CONDITIONS	$T_A$	VCC	MIN	TYP	MAX	UNIT
$I_{AM,1MHz}$ Active mode (AM) current (1MHz)	$f_{DCO} = f_{MCLK} = f_{SMCLK} = 1MHz$ , $f_{ACLK} = 32,768Hz$ , Program executes in flash, BCSCTL1 = CALBC1_1MHz, DCOCTL = CALDCO_1MHz, CPUOFF = 0, SCG0 = 0, SCG1 = 0, OSCOFF = 0		2.2 V		250	300	$\mu A$
			3 V		350	410	
$I_{AM,1MHz}$ Active mode (AM) current (1MHz)	$f_{DCO} = f_{MCLK} = f_{SMCLK} = 1MHz$ , $f_{ACLK} = 32,768Hz$ , Program executes in RAM, BCSCTL1 = CALBC1_1MHz, DCOCTL = CALDCO_1MHz, CPUOFF = 0, SCG0 = 0, SCG1 = 0, OSCOFF = 0		2.2 V		200		$\mu A$
			3 V		300		
$I_{AM,4kHz}$ Active mode (AM) current (4kHz)	$f_{MCLK} = f_{SMCLK} =$ $f_{ACLK} = 32,768Hz/8 = 4,096Hz$ , $f_{DCO} = 0Hz$ , Program executes in flash, SELMx = 11, SELS = 1, DIVMx = DIVSx = DIVAx = 11, CPUOFF = 0, SCG0 = 1, SCG1 = 0, OSCOFF = 0	-40–85°C	2.2 V		2	5	$\mu A$
		105°C	2.2 V			6	
		-40–85°C	3 V		3	9	
		105°C	3 V			9	
$I_{AM,100kHz}$ Active mode (AM) current (100kHz)	$f_{MCLK} = f_{SMCLK} = f_{DCO(0,0)} \approx 100kHz$ , $f_{ACLK} = 0Hz$ , Program executes in flash, RSELx = 0, DCOx = 0, CPUOFF = 0, SCG0 = 0, SCG1 = 0, OSCOFF = 1		2.2 V		60	85	$\mu A$
			3 V		72	95	

- NOTES: 1. All inputs are tied to 0 V or  $V_{CC}$ . Outputs do not source or sink any current.  
2. The currents are characterized with a Micro Crystal CC4V–T1A SMD crystal with a load capacitance of 9 pF. The internal and external load capacitance is chosen to closely match the required 9pF.

# MSP430x21x1 MIXED SIGNAL MICROCONTROLLER

SLAS439C – SEPTEMBER 2004 – REVISED JULY 2006

## typical characteristics – active mode supply current (into $V_{CC}$ )

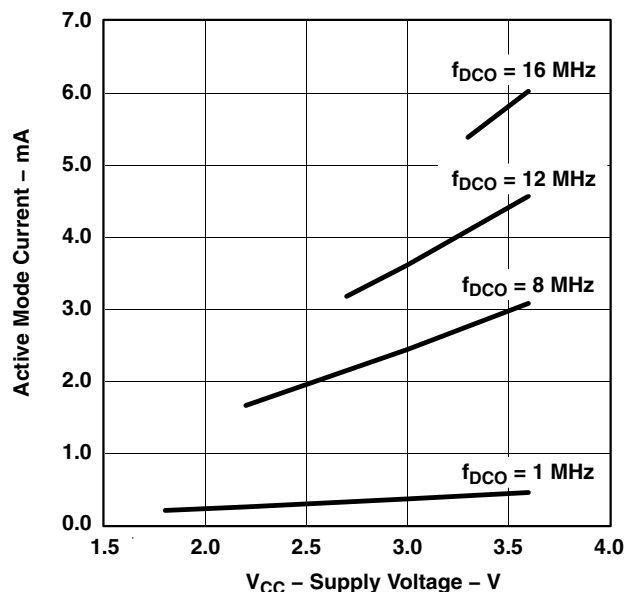

Figure 2. Active mode current vs  $V_{CC}$ ,  $T_A = 25^\circ\text{C}$

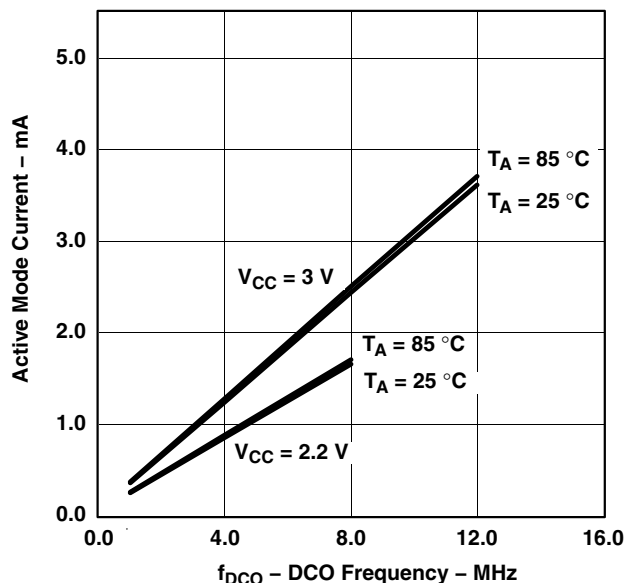

Figure 3. Active mode current vs DCO frequency

**electrical characteristics over recommended ranges of supply voltage and operating free-air temperature (unless otherwise noted) (continued)**

**low power mode supply currents (into  $V_{CC}$ ) excluding external current (see Notes 1 and 2)**

PARAMETER	TEST CONDITIONS	$T_A$	VCC	MIN	TYP	MAX	UNIT	
$I_{LPM0,1MHz}$ Low-power mode 0 (LPM0) current, see Note 3	$f_{MCLK} = 0MHz,$ $f_{SMCLK} = f_{DCO} = 1MHz,$ $f_{ACLK} = 32,768Hz,$ BCSCTL1 = CALBC1_1MHz, DCOCTL = CALDCO_1MHz, CPUOFF = 1, SCG0 = 0, SCG1 = 0, OSCOFF = 0		2.2 V		65	80	$\mu A$	
			3 V		85	100		
$I_{LPM0,100kHz}$ Low-power mode 0 (LPM0) current, see Note 3	$f_{MCLK} = 0MHz,$ $f_{SMCLK} = f_{DCO}(0, 0) \approx 100kHz,$ $f_{ACLK} = 0Hz,$ RSELx = 0, DCOx = 0, CPUOFF = 1, SCG0 = 0, SCG1 = 0, OSCOFF = 1		2.2 V		37	48	$\mu A$	
			3 V		41	52		
$I_{LPM2}$ Low-power mode 2 (LPM2) current, see Note 4	$f_{MCLK} = f_{SMCLK} = 0MHz, f_{DCO} = 1MHz,$ $f_{ACLK} = 32,768Hz,$ BCSCTL1 = CALBC1_1MHz, DCOCTL = CALDCO_1MHz, CPUOFF = 1, SCG0 = 0, SCG1 = 1, OSCOFF = 0	-40–85°C	2.2 V		22	29	$\mu A$	
				105°C		31		
		-40–85°C	3 V		25	32		
				105°C		34		
$I_{LPM3,LFXT1}$ Low-power mode 3 (LPM3) current, see Note 4	$f_{DCO} = f_{MCLK} = f_{SMCLK} = 0MHz,$ $f_{ACLK} = 32,768Hz,$ CPUOFF = 1, SCG0 = 1, SCG1 = 1, OSCOFF = 0	-40°C	2.2 V		0.7	1.2	$\mu A$	
				25°C		0.7		1.0
				85°C		1.6		2.3
				105°C		3		6
		-40°C	3 V		0.9	1.2	$\mu A$	
				25°C		0.9		1.2
				85°C		1.6		2.8
				105°C		3		7
$I_{LPM4}$ Low-power mode 4 (LPM4) current, see Note 5	$f_{DCO} = f_{MCLK} = f_{SMCLK} = 0MHz,$ $f_{ACLK} = 0Hz,$ CPUOFF = 1, SCG0 = 1, SCG1 = 1, OSCOFF = 1	-40°C	2.2 V/3 V		0.1	0.5	$\mu A$	
				25°C		0.1		0.5
				85°C		0.8		1.9
				105°C		2		4

- NOTES: 1. All inputs are tied to 0 V or  $V_{CC}$ . Outputs do not source or sink any current.  
2. The currents are characterized with a Micro Crystal CC4V–T1A SMD crystal with a load capacitance of 9 pF. The internal and external load capacitance is chosen to closely match the required 9pF.  
3. Current for brownout and WDT clocked by SMCLK included.  
4. Current for brownout and WDT clocked by ACLK included.  
5. Current for brownout included.

# MSP430x21x1 MIXED SIGNAL MICROCONTROLLER

SLAS439C – SEPTEMBER 2004 – REVISED JULY 2006

electrical characteristics over recommended ranges of supply voltage and operating free-air temperature (unless otherwise noted) (continued)

## Schmitt-trigger inputs – Ports P1 and P2

PARAMETER	TEST CONDITIONS	VCC	MIN	TYP	MAX	UNIT
V <sub>IT+</sub>	Positive-going input threshold voltage		0.45		0.75	V <sub>CC</sub>
		2.2 V	1.00		1.65	V
		3 V	1.35		2.25	V
V <sub>IT-</sub>	Negative-going input threshold voltage		0.25		0.55	V <sub>CC</sub>
		2.2 V	0.55		1.20	V
		3 V	0.75		1.65	V
V <sub>hys</sub>	Input voltage hysteresis (V <sub>IT+</sub> – V <sub>IT-</sub> )	2.2 V	0.2		1.0	V
		3 V	0.3		1.0	V
R <sub>Pull</sub>	Pull-up/pull-down resistor	For pull-up: V <sub>IN</sub> = V <sub>SS</sub> ; For pull-down: V <sub>IN</sub> = V <sub>CC</sub>	20	35	50	kΩ
C <sub>I</sub>	Input Capacitance	V <sub>IN</sub> = V <sub>SS</sub> or V <sub>CC</sub>		5		pF

## inputs – Ports P1 and P2

PARAMETER	TEST CONDITIONS	VCC	MIN	TYP	MAX	UNIT
t <sub>(int)</sub>	Port P1, P2: P1.x to P2.x, External trigger puls width to set interrupt flag, (see Note 1)	2.2 V/3 V	20			ns

NOTES: 1. An external signal sets the interrupt flag every time the minimum interrupt puls width t<sub>(int)</sub> is met. It may be set even with trigger signals shorter than t<sub>(int)</sub>.

## leakage current – Ports P1 and P2

PARAMETER	TEST CONDITIONS	VCC	MIN	TYP	MAX	UNIT
I <sub>lkg(Px.x)</sub>	High-impedance leakage current	see Notes 1 and 2			±50	nA

NOTES: 1. The leakage current is measured with V<sub>SS</sub> or V<sub>CC</sub> applied to the corresponding pin(s), unless otherwise noted.  
2. The leakage of the digital port pins is measured individually. The port pin is selected for input and the pull-up/pull-down resistor is disabled.



**electrical characteristics over recommended ranges of supply voltage and operating free-air temperature (unless otherwise noted) (continued)**

**outputs – Ports P1 and P2**

PARAMETER		TEST CONDITIONS	VCC	MIN	TYP	MAX	UNIT
V <sub>OH</sub>	High-level output voltage	I <sub>(OHmax)</sub> = -1.5 mA (see Note 1)	2.2 V	V <sub>CC</sub> -0.25		V <sub>CC</sub>	V
		I <sub>(OHmax)</sub> = -6 mA (see Note 2)	2.2 V	V <sub>CC</sub> -0.6		V <sub>CC</sub>	
		I <sub>(OHmax)</sub> = -1.5 mA (see Note 1)	3 V	V <sub>CC</sub> -0.25		V <sub>CC</sub>	
		I <sub>(OHmax)</sub> = -6 mA (see Note 2)	3 V	V <sub>CC</sub> -0.6		V <sub>CC</sub>	
V <sub>OL</sub>	Low-level output voltage	I <sub>(OLmax)</sub> = 1.5 mA (see Note 1)	2.2 V	V <sub>SS</sub>		V <sub>SS</sub> +0.25	V
		I <sub>(OLmax)</sub> = 6 mA (see Note 2)	2.2 V	V <sub>SS</sub>		V <sub>SS</sub> +0.6	
		I <sub>(OLmax)</sub> = 1.5 mA (see Note 1)	3 V	V <sub>SS</sub>		V <sub>SS</sub> +0.25	
		I <sub>(OLmax)</sub> = 6 mA (see Note 2)	3 V	V <sub>SS</sub>		V <sub>SS</sub> +0.6	

- NOTES: 1. The maximum total current, I<sub>OHmax</sub> and I<sub>OLmax</sub>, for all outputs combined, should not exceed ±12 mA to hold the maximum voltage drop specified.  
 2. The maximum total current, I<sub>OHmax</sub> and I<sub>OLmax</sub>, for all outputs combined, should not exceed ±48 mA to hold the maximum voltage drop specified.

**output frequency – Ports P1 and P2**

PARAMETER		TEST CONDITIONS	VCC	MIN	TYP	MAX	UNIT
f <sub>Px.y</sub>	Port output frequency (with load)	P1.4/SMCLK, C <sub>L</sub> = 20 pF, R <sub>L</sub> = 1 kOhm (see Note 1 and 2)	2.2 V			10	MHz
			3 V			12	MHz
f <sub>Port_CLK</sub>	Clock output frequency	P2.0/ACLK, P1.4/SMCLK, C <sub>L</sub> = 20 pF (see Note 2)	2.2 V			12	MHz
			3 V			16	MHz

- NOTES: 1. A resistive divider with 2 times 0.5 kΩ between V<sub>CC</sub> and V<sub>SS</sub> is used as load. The output is connected to the center tap of the divider.  
 2. The output voltage reaches at least 10% and 90% V<sub>CC</sub> at the specified toggle frequency.

# MSP430x21x1 MIXED SIGNAL MICROCONTROLLER

SLAS439C – SEPTEMBER 2004 – REVISED JULY 2006

electrical characteristics over recommended ranges of supply voltage and operating free-air temperature (unless otherwise noted) (continued)

typical characteristics – outputs

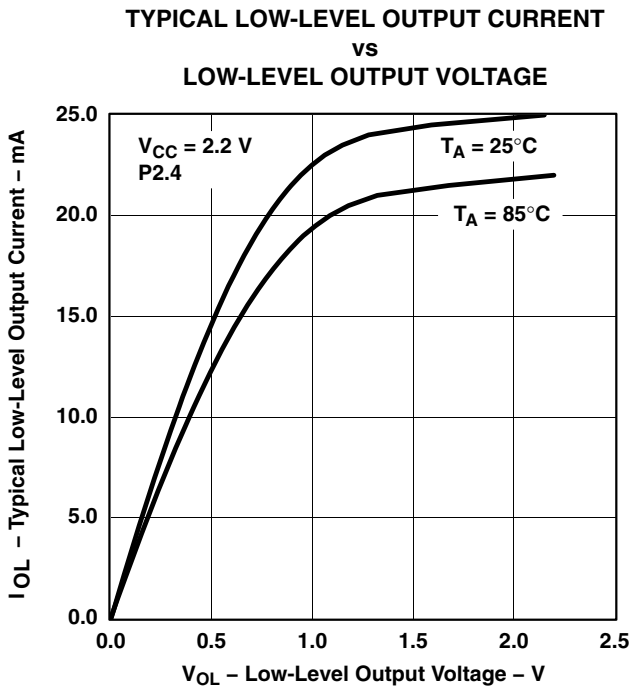

Figure 4

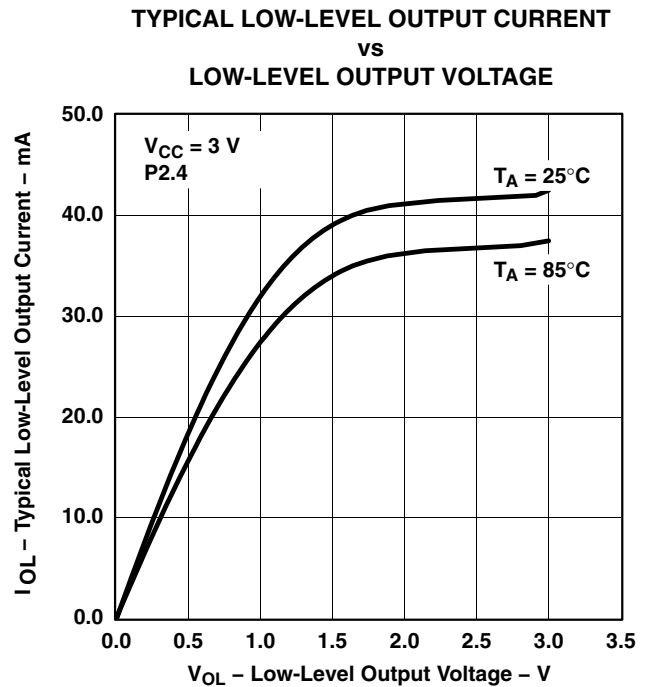

Figure 5

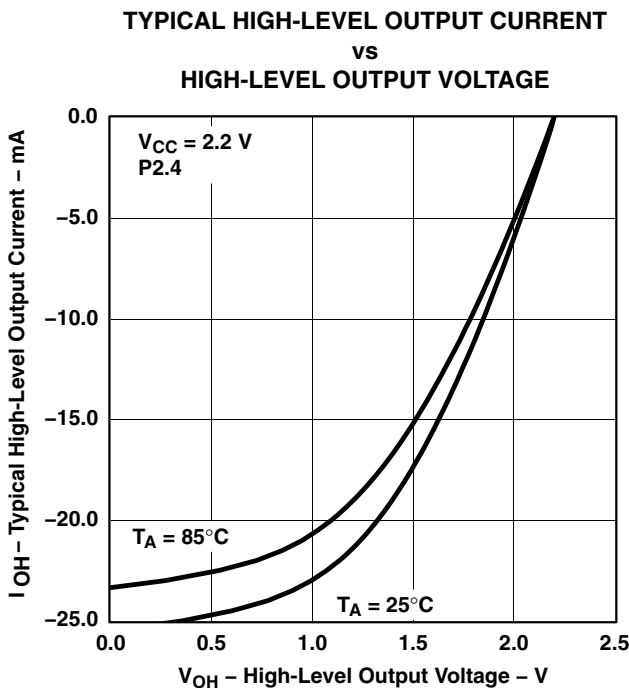

Figure 6

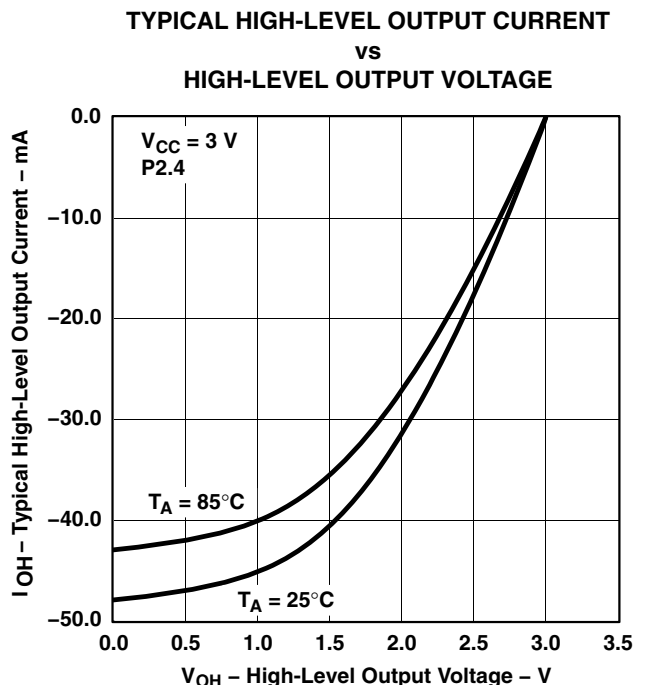

Figure 7

NOTE: One output loaded at a time.

electrical characteristics over recommended ranges of supply voltage and operating free-air temperature (unless otherwise noted) (continued)

**POR/brownout reset (BOR) (see Notes 1 and 2)**

PARAMETER	TEST CONDITIONS	T <sub>A</sub>	V <sub>CC</sub>	MIN	TYP	MAX	UNIT
V <sub>CC(start)</sub> (see Figure 8)	dV <sub>CC</sub> /dt ≤ 3 V/s			0.7 × V <sub>(B_IT-)</sub>			V
V <sub>(B_IT-)</sub> (see Figure 8 through Figure 10)	dV <sub>CC</sub> /dt ≤ 3 V/s			1.71			V
V <sub>hys(B_IT-)</sub> (see Figure 8)	dV <sub>CC</sub> /dt ≤ 3 V/s	-40–85°C		70	130	180	mV
		105°C		70	130	210	mV
t <sub>d(BOR)</sub> (see Figure 8)				2000			μs
t <sub>(reset)</sub>	Pulse length needed at $\overline{\text{RST}}/\text{NMI}$ pin to accepted reset internally		2.2 V/3 V	2			μs

- NOTES: 1. The current consumption of the brownout module is already included in the I<sub>CC</sub> current consumption data. The voltage level V<sub>(B\_IT-)</sub> + V<sub>hys(B\_IT-)</sub> is ≤ 1.8V.  
 2. During power up, the CPU begins code execution following a period of t<sub>d(BOR)</sub> after V<sub>CC</sub> = V<sub>(B\_IT-)</sub> + V<sub>hys(B\_IT-)</sub>. The default DCO settings must not be changed until V<sub>CC</sub> ≥ V<sub>CC(min)</sub>, where V<sub>CC(min)</sub> is the minimum supply voltage for the desired operating frequency.

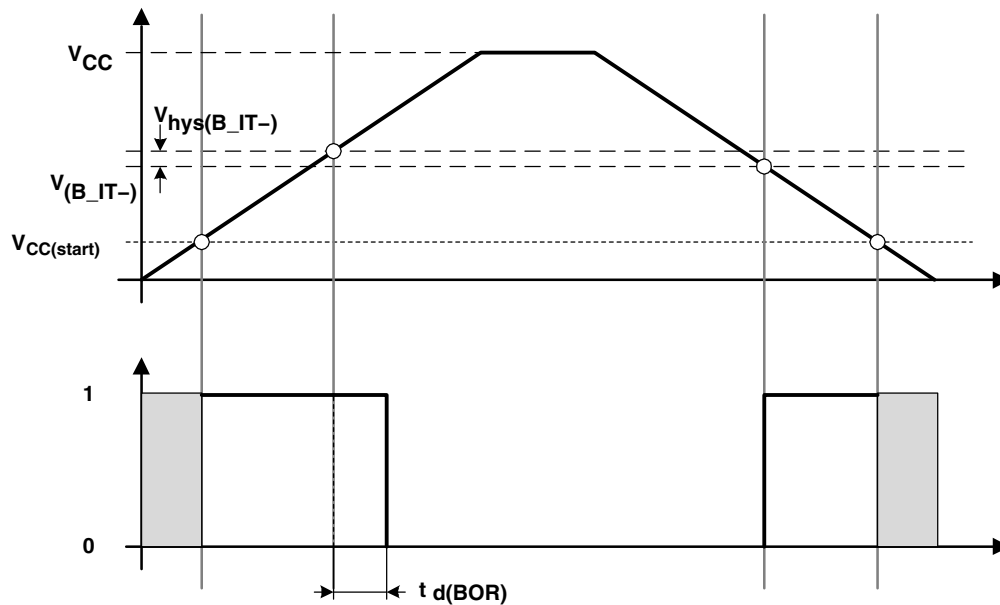

Figure 8. POR/Brownout Reset (BOR) vs Supply Voltage

# MSP430x21x1 MIXED SIGNAL MICROCONTROLLER

SLAS439C – SEPTEMBER 2004 – REVISED JULY 2006

electrical characteristics over recommended ranges of supply voltage and operating free-air temperature (unless otherwise noted) (continued)

typical characteristics – POR/brownout reset (BOR)

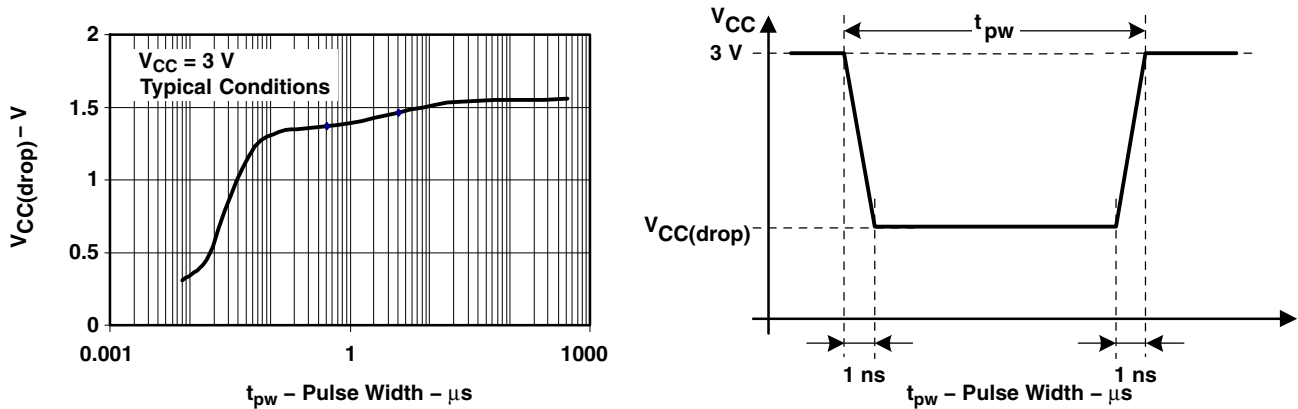

Figure 9.  $V_{CC(drop)}$  Level With a Square Voltage Drop to Generate a POR/Brownout Signal

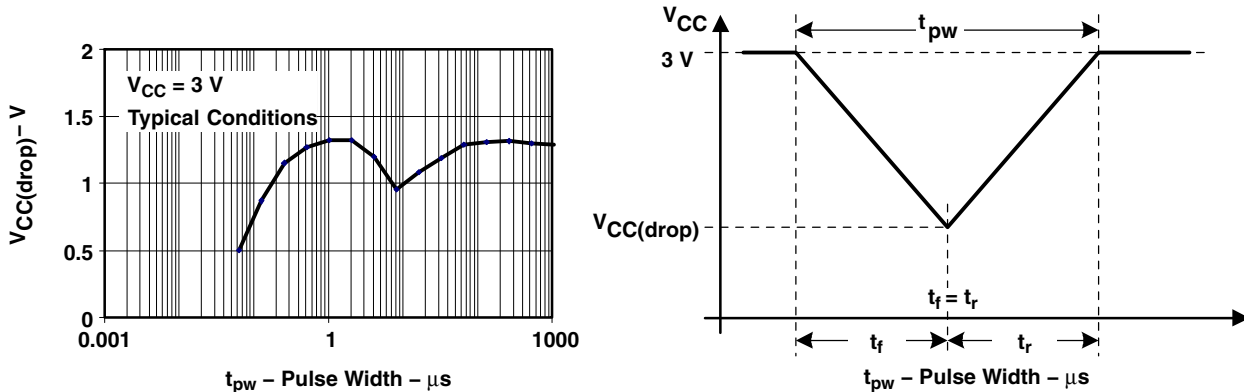

Figure 10.  $V_{CC(drop)}$  Level With a Triangle Voltage Drop to Generate a POR/Brownout Signal

**electrical characteristics over recommended ranges of supply voltage and operating free-air temperature (unless otherwise noted) (continued)**

**main DCO characteristics**

- All ranges selected by RSELx overlap with RSELx + 1: RSELx = 0 overlaps RSELx = 1, ... RSELx = 14 overlaps RSELx = 15.
- DCO control bits DCOx have a step size as defined by parameter S<sub>DCO</sub>.
- Modulation control bits MODx select how often f<sub>DCO(RSEL,DCO+1)</sub> is used within the period of 32 DCOCLK cycles. The frequency f<sub>DCO(RSEL,DCO)</sub> is used for the remaining cycles. The frequency is an average equal to:

$$f_{average} = \frac{32 \times f_{DCO(RSEL,DCO)} \times f_{DCO(RSEL,DCO+1)}}{MOD \times f_{DCO(RSEL,DCO)} + (32 - MOD) \times f_{DCO(RSEL,DCO+1)}}$$

**DCO frequency**

PARAMETER	TEST CONDITIONS	VCC	MIN	TYP	MAX	UNIT	
Vcc	Supply voltage range		1.8		3.6	V	
			2.2		3.6	V	
			3.0		3.6	V	
f <sub>DCO(0,0)</sub>	DCO frequency (0, 0)	RSELx = 0, DCOx = 0, MODx = 0	2.2 V/3 V	0.06	0.14	MHz	
f <sub>DCO(0,3)</sub>	DCO frequency (0, 3)	RSELx = 0, DCOx = 3, MODx = 0	2.2 V/3 V	0.07	0.17	MHz	
f <sub>DCO(1,3)</sub>	DCO frequency (1, 3)	RSELx = 1, DCOx = 3, MODx = 0	2.2 V/3 V	0.10	0.20	MHz	
f <sub>DCO(2,3)</sub>	DCO frequency (2, 3)	RSELx = 2, DCOx = 3, MODx = 0	2.2 V/3 V	0.14	0.28	MHz	
f <sub>DCO(3,3)</sub>	DCO frequency (3, 3)	RSELx = 3, DCOx = 3, MODx = 0	2.2 V/3 V	0.20	0.40	MHz	
f <sub>DCO(4,3)</sub>	DCO frequency (4, 3)	RSELx = 4, DCOx = 3, MODx = 0	2.2 V/3 V	0.28	0.54	MHz	
f <sub>DCO(5,3)</sub>	DCO frequency (5, 3)	RSELx = 5, DCOx = 3, MODx = 0	2.2 V/3 V	0.39	0.77	MHz	
f <sub>DCO(6,3)</sub>	DCO frequency (6, 3)	RSELx = 6, DCOx = 3, MODx = 0	2.2 V/3 V	0.54	1.06	MHz	
f <sub>DCO(7,3)</sub>	DCO frequency (7, 3)	RSELx = 7, DCOx = 3, MODx = 0	2.2 V/3 V	0.80	1.50	MHz	
f <sub>DCO(8,3)</sub>	DCO frequency (8, 3)	RSELx = 8, DCOx = 3, MODx = 0	2.2 V/3 V	1.10	2.10	MHz	
f <sub>DCO(9,3)</sub>	DCO frequency (9, 3)	RSELx = 9, DCOx = 3, MODx = 0	2.2 V/3 V	1.60	3.00	MHz	
f <sub>DCO(10,3)</sub>	DCO frequency (10, 3)	RSELx = 10, DCOx = 3, MODx = 0	2.2 V/3 V	2.50	4.30	MHz	
f <sub>DCO(11,3)</sub>	DCO frequency (11, 3)	RSELx = 11, DCOx = 3, MODx = 0	2.2 V/3 V	3.00	5.50	MHz	
f <sub>DCO(12,3)</sub>	DCO frequency (12, 3)	RSELx = 12, DCOx = 3, MODx = 0	2.2 V/3 V	4.30	7.30	MHz	
f <sub>DCO(13,3)</sub>	DCO frequency (13, 3)	RSELx = 13, DCOx = 3, MODx = 0	2.2 V/3 V	6.00	9.60	MHz	
f <sub>DCO(14,3)</sub>	DCO frequency (14, 3)	RSELx = 14, DCOx = 3, MODx = 0	2.2 V/3 V	8.60	13.9	MHz	
f <sub>DCO(15,3)</sub>	DCO frequency (15, 3)	RSELx = 15, DCOx = 3, MODx = 0	3 V	12.0	18.5	MHz	
f <sub>DCO(15,7)</sub>	DCO frequency (15, 7)	RSELx = 15, DCOx = 7, MODx = 0	3 V	16.0	26.0	MHz	
S <sub>RSEL</sub>	Frequency step between range RSEL and RSEL+1	S <sub>RSEL</sub> = f <sub>DCO(RSEL+1,DCO)</sub> /f <sub>DCO(RSEL,DCO)</sub>	2.2 V/3 V		1.55	ratio	
S <sub>DCO</sub>	Frequency step between tap DCO and DCO+1	S <sub>DCO</sub> = f <sub>DCO(RSEL,DCO+1)</sub> /f <sub>DCO(RSEL,DCO)</sub>	2.2 V/3 V	1.05	1.08		1.12
Duty Cycle		Measured at P1.4/SMCLK	2.2 V/3 V	40	50	60	%

# MSP430x21x1 MIXED SIGNAL MICROCONTROLLER

SLAS439C – SEPTEMBER 2004 – REVISED JULY 2006

**electrical characteristics over recommended ranges of supply voltage and operating free-air temperature (unless otherwise noted) (continued)**

## calibrated DCO frequencies – tolerance at calibration

PARAMETER	TEST CONDITIONS	T <sub>A</sub>	VCC	MIN	TYP	MAX	UNIT
Frequency tolerance at calibration		25°C	3 V	-1	±0.2	+1	%
f <sub>CAL(1MHz)</sub> 1MHz calibration value	BCSCTL1= CALBC1_1MHZ DCOCTL = CALDCO_1MHZ Gating time: 5ms	25°C	3 V	0.990	1	1.010	MHz
f <sub>CAL(8MHz)</sub> 8MHz calibration value	BCSCTL1= CALBC1_8MHZ DCOCTL = CALDCO_8MHZ Gating time: 5ms	25°C	3 V	7.920	8	8.080	MHz
f <sub>CAL(12MHz)</sub> 12MHz calibration value	BCSCTL1= CALBC1_12MHZ DCOCTL = CALDCO_12MHZ Gating time: 5ms	25°C	3 V	11.88	12	12.12	MHz
f <sub>CAL(16MHz)</sub> 16MHz calibration value	BCSCTL1= CALBC1_16MHZ DCOCTL = CALDCO_16MHZ Gating time: 2ms	25°C	3 V	15.84	16	16.16	MHz

## calibrated DCO frequencies – tolerance over temperature 0°C – +85°C

PARAMETER	TEST CONDITIONS	T <sub>A</sub>	VCC	MIN	TYP	MAX	UNIT
1 MHz tolerance over temperature		0–85°C	3.0 V	-2.5	±0.5	+2.5	%
8 MHz tolerance over temperature		0–85°C	3.0 V	-2.5	±1.0	+2.5	%
12 MHz tolerance over temperature		0–85°C	3.0 V	-2.5	±1.0	+2.5	%
16 MHz tolerance over temperature		0–85°C	3.0 V	-3.0	±2.0	+3.0	%
f <sub>CAL(1MHz)</sub> 1MHz calibration value	BCSCTL1= CALBC1_1MHZ DCOCTL = CALDCO_1MHZ Gating time: 5ms	0–85°C	2.2 V	0.970	1	1.030	MHz
			3.0 V	0.975	1	1.025	MHz
			3.6 V	0.970	1	1.030	MHz
f <sub>CAL(8MHz)</sub> 8MHz calibration value	BCSCTL1= CALBC1_8MHZ DCOCTL = CALDCO_8MHZ Gating time: 5ms	0–85°C	2.2 V	7.760	8	8.400	MHz
			3.0 V	7.800	8	8.200	MHz
			3.6 V	7.600	8	8.240	MHz
f <sub>CAL(12MHz)</sub> 12MHz calibration value	BCSCTL1= CALBC1_12MHZ DCOCTL = CALDCO_12MHZ Gating time: 5ms	0–85°C	2.2 V	11.70	12	12.30	MHz
			3.0 V	11.70	12	12.30	MHz
			3.6 V	11.70	12	12.30	MHz
f <sub>CAL(16MHz)</sub> 16MHz calibration value	BCSCTL1= CALBC1_16MHZ DCOCTL = CALDCO_16MHZ Gating time: 2ms	0–85°C	3.0 V	15.52	16	16.48	MHz
			3.6 V	15.00	16	16.48	MHz



**electrical characteristics over recommended ranges of supply voltage and operating free-air temperature (unless otherwise noted) (continued)**

**calibrated DCO frequencies – tolerance over supply voltage  $V_{CC}$**

PARAMETER	TEST CONDITIONS	$T_A$	VCC	MIN	TYP	MAX	UNIT
1 MHz tolerance over $V_{CC}$		25°C	1.8 V – 3.6 V	-3	±2	+3	%
8 MHz tolerance over $V_{CC}$		25°C	1.8 V – 3.6 V	-3	±2	+3	%
12 MHz tolerance over $V_{CC}$		25°C	2.2 V – 3.6 V	-3	±2	+3	%
16 MHz tolerance over $V_{CC}$		25°C	3.0 V – 3.6 V	-3	±2	+3	%
$f_{CAL(1MHz)}$ 1MHz calibration value	BCSCTL1= CALBC1_1MHZ DCOCTL = CALDCO_1MHZ Gating time: 5ms	25°C	1.8 V – 3.6 V	0.970	1	1.030	MHz
$f_{CAL(8MHz)}$ 8MHz calibration value	BCSCTL1= CALBC1_8MHZ DCOCTL = CALDCO_8MHZ Gating time: 5ms	25°C	1.8 V – 3.6 V	7.760	8	8.240	MHz
$f_{CAL(12MHz)}$ 12MHz calibration value	BCSCTL1= CALBC1_12MHZ DCOCTL = CALDCO_12MHZ Gating time: 5ms	25°C	2.2 V – 3.6 V	11.64	12	12.36	MHz
$f_{CAL(16MHz)}$ 16MHz calibration value	BCSCTL1= CALBC1_16MHZ DCOCTL = CALDCO_16MHZ Gating time: 2ms	25°C	3.0 V – 3.6 V	15.00	16	16.48	MHz

**calibrated DCO frequencies – overall tolerance**

PARAMETER	TEST CONDITIONS	$T_A$	VCC	MIN	TYP	MAX	UNIT
1 MHz tolerance overall		I: -40–85°C T: -40–105°C	1.8 V – 3.6 V	-5	±2	+5	%
8 MHz tolerance overall		I: -40–85°C T: -40–105°C	1.8 V – 3.6 V	-5	±2	+5	%
12 MHz tolerance overall		I: -40–85°C T: -40–105°C	2.2 V – 3.6 V	-5	±2	+5	%
16 MHz tolerance overall		I: -40–85°C T: -40–105°C	3.0 V – 3.6 V	-6	±3	+6	%
$f_{CAL(1MHz)}$ 1MHz calibration value	BCSCTL1= CALBC1_1MHZ DCOCTL = CALDCO_1MHZ Gating time: 5ms	I: -40–85°C T: -40–105°C	1.8 V – 3.6 V	0.950	1	1.050	MHz
$f_{CAL(8MHz)}$ 8MHz calibration value	BCSCTL1= CALBC1_8MHZ DCOCTL = CALDCO_8MHZ Gating time: 5ms	I: -40–85°C T: -40–105°C	1.8 V – 3.6 V	7.600	8	8.400	MHz
$f_{CAL(12MHz)}$ 12MHz calibration value	BCSCTL1= CALBC1_12MHZ DCOCTL = CALDCO_12MHZ Gating time: 5ms	I: -40–85°C T: -40–105°C	2.2 V – 3.6 V	11.40	12	12.60	MHz
$f_{CAL(16MHz)}$ 16MHz calibration value	BCSCTL1= CALBC1_16MHZ DCOCTL = CALDCO_16MHZ Gating time: 2ms	I: -40–85°C T: -40–105°C	3.0 V – 3.6 V	15.00	16	17.00	MHz

# MSP430x21x1 MIXED SIGNAL MICROCONTROLLER

SLAS439C – SEPTEMBER 2004 – REVISED JULY 2006

electrical characteristics over recommended ranges of supply voltage and operating free-air temperature (unless otherwise noted) (continued)

typical characteristics – calibrated 1MHz DCO frequency

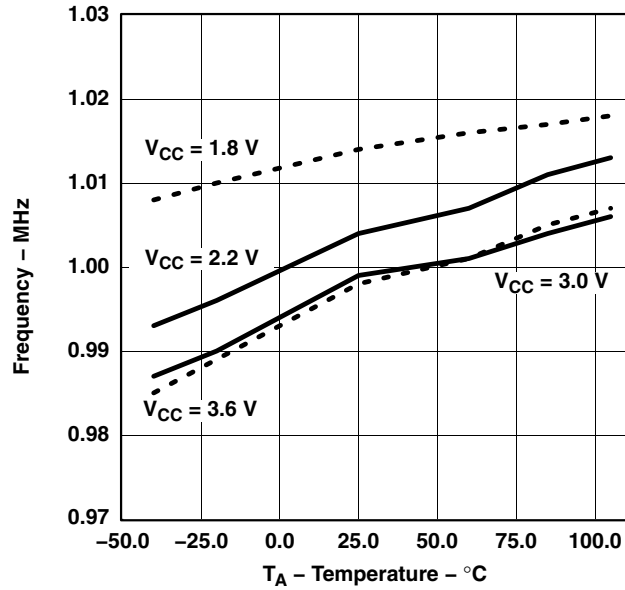

Figure 11. Calibrated 1 MHz Frequency vs. Temperature

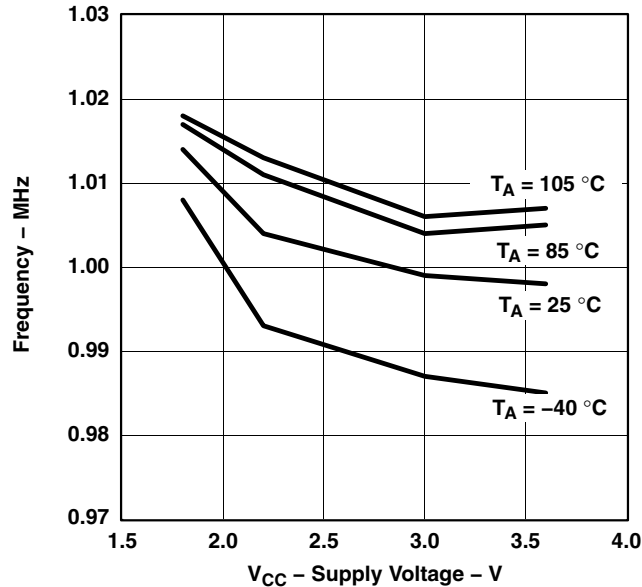

Figure 12. Calibrated 1 MHz Frequency vs. V<sub>CC</sub>



electrical characteristics over recommended ranges of supply voltage and operating free-air temperature (unless otherwise noted) (continued)

wake-up from lower power modes (LPM3/4)

PARAMETER	TEST CONDITIONS	VCC	MIN	TYP	MAX	UNIT
$t_{DCO,LPM3/4}$ DCO clock wake-up time from LPM3/4 (see Note 1)	BCSCTL1= CALBC1_1MHZ; DCOCTL = CALDCO_1MHZ	2.2 V/3 V			2	$\mu\text{s}$
	BCSCTL1= CALBC1_8MHZ; DCOCTL = CALDCO_8MHZ	2.2 V/3 V			1.5	
	BCSCTL1= CALBC1_12MHZ; DCOCTL = CALDCO_12MHZ	2.2 V/3 V			1	
	BCSCTL1= CALBC1_16MHZ; DCOCTL = CALDCO_16MHZ	3 V			1	
$t_{CPU,LPM3/4}$ CPU wake-up time from LPM3/4 (see Note 2)				$1/f_{MCLK} +$ $t_{Clock,LPM3/4}$		

- NOTES: 1. The DCO clock wake-up time is measured from the edge of an external wake-up signal (e.g. port interrupt) to the first clock edge observable externally on a clock pin (MCLK or SMCLK).  
2. Parameter applicable only if DCOCLK is used for MCLK.

typical characteristics – DCO clock wake-up time from LPM3/4

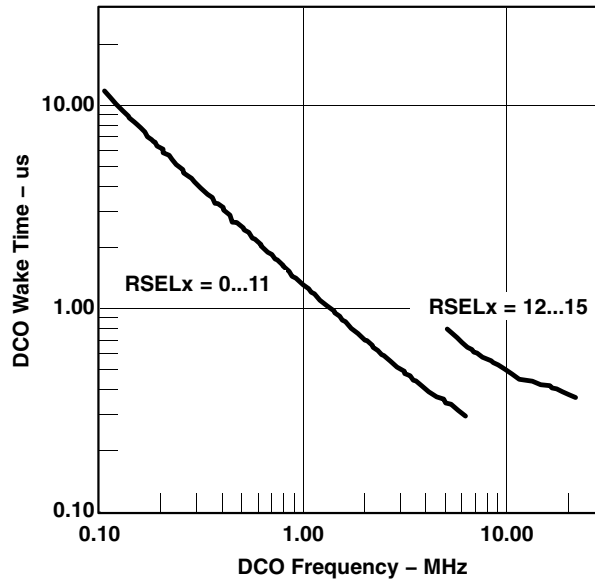

Figure 13. DCO wake-up time from LPM3 vs DCO frequency

# MSP430x21x1 MIXED SIGNAL MICROCONTROLLER

SLAS439C – SEPTEMBER 2004 – REVISED JULY 2006

**electrical characteristics over recommended ranges of supply voltage and operating free-air temperature (unless otherwise noted) (continued)**

## crystal oscillator, LFXT1, low frequency modes (see Note 4)

PARAMETER		TEST CONDITIONS	VCC	MIN	TYP	MAX	UNIT
$f_{LFXT1,LF}$	LFXT1 oscillator crystal frequency, LF mode 0, 1	XTS = 0, LFXT1Sx = 0 or 1	1.8 V – 3.6 V		32,768		Hz
$f_{LFXT1,LF,logic}$	LFXT1 oscillator logic level square wave input frequency, LF mode	XTS = 0, LFXT1Sx = 3	1.8 V – 3.6 V	10,000	32,768	50,000	Hz
OALF	Oscillation Allowance for LF crystals	XTS = 0, LFXT1Sx = 0; $f_{LFXT1,LF} = 32,768$ kHz, $C_{L,eff} = 6$ pF			500		k $\Omega$
		XTS = 0, LFXT1Sx = 0; $f_{LFXT1,LF} = 32,768$ kHz, $C_{L,eff} = 12$ pF			200		k $\Omega$
$C_{L,eff}$	Integrated effective Load Capacitance, LF mode (see Note 1)	XTS = 0, XCAPx = 0			1		pF
		XTS = 0, XCAPx = 1			5.5		pF
		XTS = 0, XCAPx = 2			8.5		pF
		XTS = 0, XCAPx = 3			11		pF
Duty Cycle	LF mode	XTS = 0, Measured at P1.4/ACLK, $f_{LFXT1,LF} = 32,768$ Hz	2.2 V/3 V	30	50	70	%
$f_{Fault,LF}$	Oscillator fault frequency, LF mode (see Note 3)	XTS = 0, LFXT1Sx = 3 (see Notes 2)	2.2 V/3 V	10		10,000	Hz

- NOTES: 1. Includes parasitic bond and package capacitance (approximately 2pF per pin).  
Since the PCB adds additional capacitance it is recommended to verify the correct load by measuring the ACLK frequency. For a correct setup the effective load capacitance should always match the specification of the used crystal.
2. Measured with logic level input frequency but also applies to operation with crystals.
3. Frequencies below the MIN specification will set the fault flag, frequencies above the MAX specification will not set the fault flag. Frequencies in between might set the flag.
4. To improve EMI on the LFXT1 oscillator the following guidelines should be observed.
- Keep as short of a trace as possible between the device and the crystal.
  - Design a good ground plane around the oscillator pins.
  - Prevent crosstalk from other clock or data lines into oscillator pins XIN and XOUT.
  - Avoid running PCB traces underneath or adjacent to the XIN and XOUT pins.
  - Use assembly materials and praxis to avoid any parasitic load on the oscillator XIN and XOUT pins.
  - If conformal coating is used, ensure that it does not induce capacitive/resistive leakage between the oscillator pins.
  - Do not route the XOUT line to the JTAG header to support the serial programming adapter as shown in other documentation. This signal is no longer required for the serial programming adapter.

**electrical characteristics over recommended ranges of supply voltage and operating free-air temperature (unless otherwise noted) (continued)**

**crystal oscillator, LFXT1, high frequency modes (see Note 5)**

PARAMETER		TEST CONDITIONS	VCC	MIN	TYP	MAX	UNIT
$f_{LFXT1,HF0}$	LFXT1 oscillator crystal frequency, HF mode 0	XTS = 1, LFXT1Sx = 0	1.8 V – 3.6 V	0.4		1	MHz
$f_{LFXT1,HF1}$	LFXT1 oscillator crystal frequency, HF mode 1	XTS = 1, LFXT1Sx = 1	1.8 V – 3.6 V	1		4	MHz
$f_{LFXT1,HF2}$	LFXT1 oscillator crystal frequency, HF mode 2	XTS = 1, LFXT1Sx = 2	1.8 V – 3.6 V	2		10	MHz
			2.2 V – 3.6 V	2		12	MHz
			3.0 V – 3.6 V	2		16	MHz
$f_{LFXT1,HF,logic}$	LFXT1 oscillator logic level square wave input frequency, HF mode	XTS = 1, LFXT1Sx = 3	1.8 V – 3.6 V	0.4		10	MHz
			2.2 V – 3.6 V	0.4		12	MHz
			3.0 V – 3.6 V	0.4		16	MHz
$OA_{HF}$	Oscillation Allowance for HF crystals (refer to Figure 14 and Figure 15)	XTS = 0, LFXT1Sx = 0, $f_{LFXT1,HF} = 1$ MHz, $C_{L,eff} = 15$ pF			2700		$\Omega$
		XTS = 0, LFXT1Sx = 1 $f_{LFXT1,HF} = 4$ MHz, $C_{L,eff} = 15$ pF			800		$\Omega$
		XTS = 0, LFXT1Sx = 2 $f_{LFXT1,HF} = 16$ MHz, $C_{L,eff} = 15$ pF			300		$\Omega$
$C_{L,eff}$	Integrated effective Load Capacitance, HF mode (see Note 1)	XTS = 1 (see Note 2)			1		pF
Duty Cycle	HF mode	XTS = 1, Measured at P1.4/ACLK, $f_{LFXT1,HF} = 10$ MHz	2.2 V/3 V	40	50	60	%
		XTS = 1, Measured at P1.4/ACLK, $f_{LFXT1,HF} = 16$ MHz	2.2 V/3 V	40	50	60	%
$f_{Fault,HF}$	Oscillator fault frequency, HF mode (see Note 4)	XTS = 1, LFXT1Sx = 3 (see Notes 3)	2.2 V/3 V	30		300	kHz

- NOTES: 1. Includes parasitic bond and package capacitance (approximately 2pF per pin).  
Since the PCB adds additional capacitance it is recommended to verify the correct load by measuring the ACLK frequency. For a correct setup the effective load capacitance should always match the specification of the used crystal.
2. Requires external capacitors at both terminals. Values are specified by crystal manufacturers.
3. Measured with logic level input frequency but also applies to operation with crystals.
4. Frequencies below the MIN specification will set the fault flag, frequencies above the MAX specification will not set the fault flag. Frequencies in between might set the flag.
5. To improve EMI on the LFXT1 oscillator the following guidelines should be observed.
- Keep as short of a trace as possible between the device and the crystal.
  - Design a good ground plane around the oscillator pins.
  - Prevent crosstalk from other clock or data lines into oscillator pins XIN and XOUT.
  - Avoid running PCB traces underneath or adjacent to the XIN and XOUT pins.
  - Use assembly materials and praxis to avoid any parasitic load on the oscillator XIN and XOUT pins.
  - If conformal coating is used, ensure that it does not induce capacitive/resistive leakage between the oscillator pins.
  - Do not route the XOUT line to the JTAG header to support the serial programming adapter as shown in other documentation. This signal is no longer required for the serial programming adapter.

# MSP430x21x1 MIXED SIGNAL MICROCONTROLLER

SLAS439C – SEPTEMBER 2004 – REVISED JULY 2006

electrical characteristics over recommended ranges of supply voltage and operating free-air temperature (unless otherwise noted) (continued)

typical characteristics – LFXT1 oscillator in HF mode (XTS = 1)

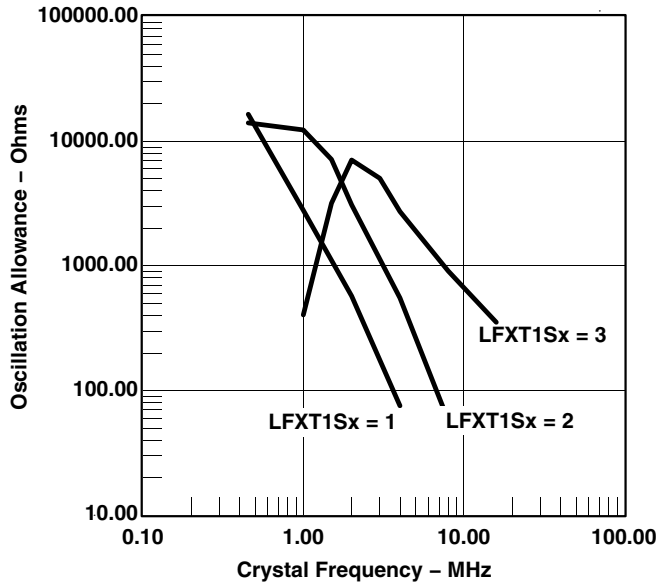

Figure 14. Oscillation Allowance vs Crystal Frequency,  $C_{L,eff} = 15 \text{ pF}$ ,  $T_A = 25^\circ\text{C}$

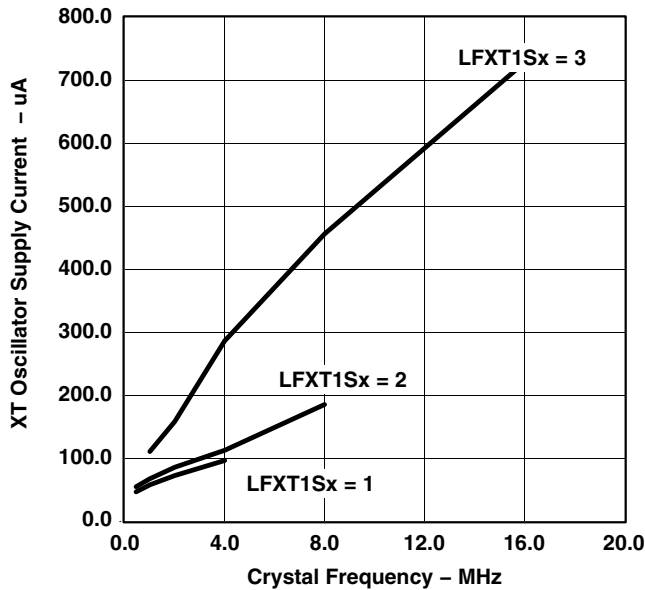

Figure 15. XT Oscillator Supply Current vs Crystal Frequency,  $C_{L,eff} = 15 \text{ pF}$ ,  $T_A = 25^\circ\text{C}$

**electrical characteristics over recommended ranges of supply voltage and operating free-air temperature (unless otherwise noted) (continued)**

**Timer\_A**

PARAMETER	TEST CONDITIONS	VCC	MIN	TYP	MAX	UNIT
f <sub>TA</sub> Timer_A clock frequency	Internal: SMCLK, ACLK; External: TACLK, INCLK; Duty Cycle = 50% ±10%	2.2 V			10	MHz
		3 V			16	
t <sub>TA,cap</sub> Timer_A, capture timing	TA0, TA1, TA2	2.2 V/3 V	20			ns

**Comparator\_A+ (see Note 1)**

PARAMETER	TEST CONDITIONS	VCC	MIN	TYP	MAX	UNIT
I <sub>(DD)</sub>	CAON=1, CARSEL=0, CAREF=0	2.2 V		25	40	μA
		3 V		45	60	
I <sub>(Refladder/RefDiode)</sub>	CAON=1, CARSEL=0, CAREF=1/2/3, no load at P2.3/CA0/TA1 and P2.4/CA1/TA2	2.2 V		30	50	μA
		3 V		45	71	
V <sub>(IC)</sub> Common-mode input voltage	CAON=1	2.2 V/3 V	0		V <sub>CC</sub> -1	V
V <sub>(Ref025)</sub> $\frac{\text{Voltage @ } 0.25 V_{CC} \text{ node}}{V_{CC}}$	PCA0=1, CARSEL=1, CAREF=1, No load at P2.3/CA0/TA1 and P2.4/CA1/TA2	2.2 V/3 V	0.23	0.24	0.25	
V <sub>(Ref050)</sub> $\frac{\text{Voltage @ } 0.5 V_{CC} \text{ node}}{V_{CC}}$	PCA0=1, CARSEL=1, CAREF=2, No load at P2.3/CA0/TA1 and P2.4/CA1/TA2	2.2 V/3 V	0.47	0.48	0.5	
V <sub>(RefVT)</sub> (see Figure 19 and Figure 20)	PCA0=1, CARSEL=1, CAREF=3, No load at P2.3/CA0/TA1 and P2.4/CA1/TA2, T <sub>A</sub> = 85°C	2.2 V	390	480	540	mV
		3 V	400	490	550	
V <sub>(offset)</sub> Offset voltage	See Note 2	2.2 V/3 V	-30		30	mV
V <sub>hys</sub> Input hysteresis	CAON=1	2.2 V/3 V	0	0.7	1.4	mV
t <sub>(response)</sub> Response time (low-high and high-low)	T <sub>A</sub> = 25°C, Overdrive 10 mV, Without filter: CAF=0 (see Note 3, Figure 16 and Figure 17)	2.2 V	80	165	300	ns
		3 V	70	120	240	
	T <sub>A</sub> = 25°C, Overdrive 10 mV, With filter: CAF=1 (see Note 3, Figure 16 and Figure 17)	2.2 V	1.4	1.9	2.8	μs
		3 V	0.9	1.5	2.2	

- NOTES: 1. The leakage current for the Comparator\_A+ terminals is identical to I<sub>lkg(Px.x)</sub> specification.  
 2. The input offset voltage can be cancelled by using the CAEX bit to invert the Comparator\_A+ inputs on successive measurements. The two successive measurements are then summed together.  
 3. Response time measured at P2.2/CAOUT.

# MSP430x21x1 MIXED SIGNAL MICROCONTROLLER

SLAS439C – SEPTEMBER 2004 – REVISED JULY 2006

electrical characteristics over recommended ranges of supply voltage and operating free-air temperature (unless otherwise noted) (continued)

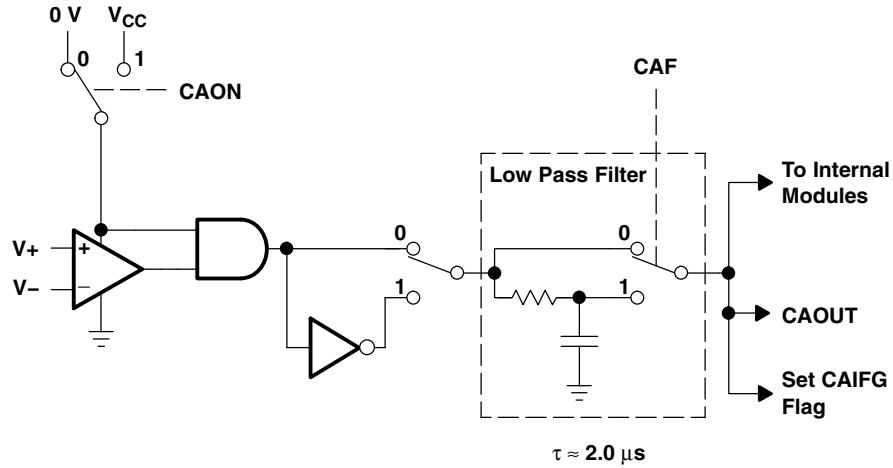

Figure 16. Block Diagram of Comparator\_A+ Module

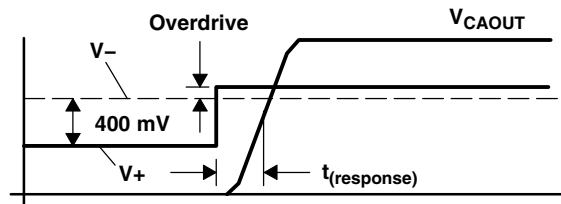

Figure 17. Overdrive Definition

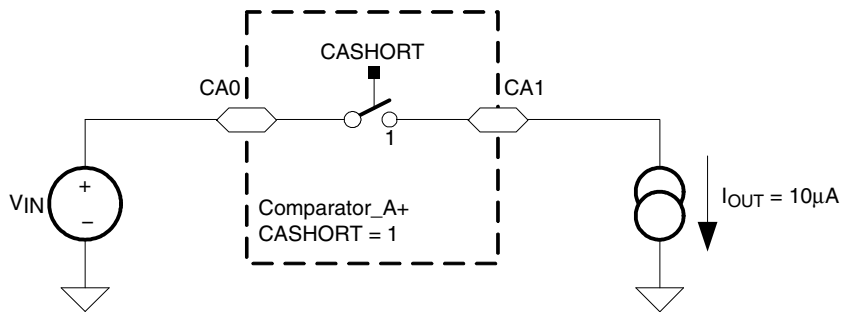

Figure 18. Comparator\_A+ Short Resistance Test Condition

electrical characteristics over recommended ranges of supply voltage and operating free-air temperature (unless otherwise noted) (continued)

typical characteristics – Comparator\_A+

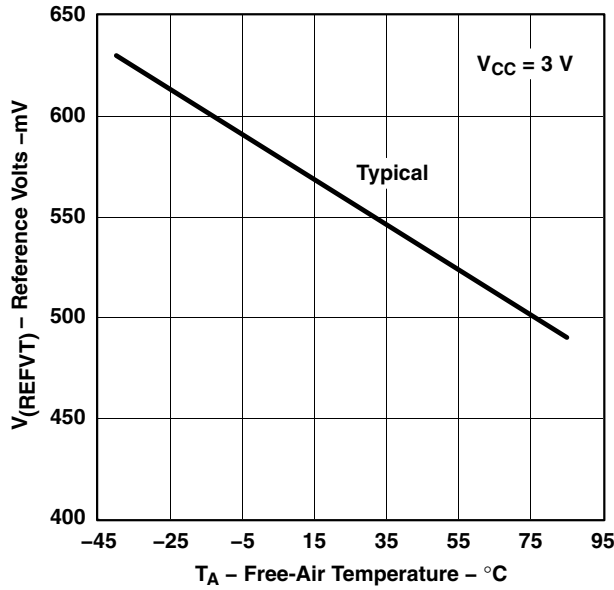

Figure 19.  $V_{(REFVT)}$  vs Temperature,  $V_{CC} = 3\text{ V}$

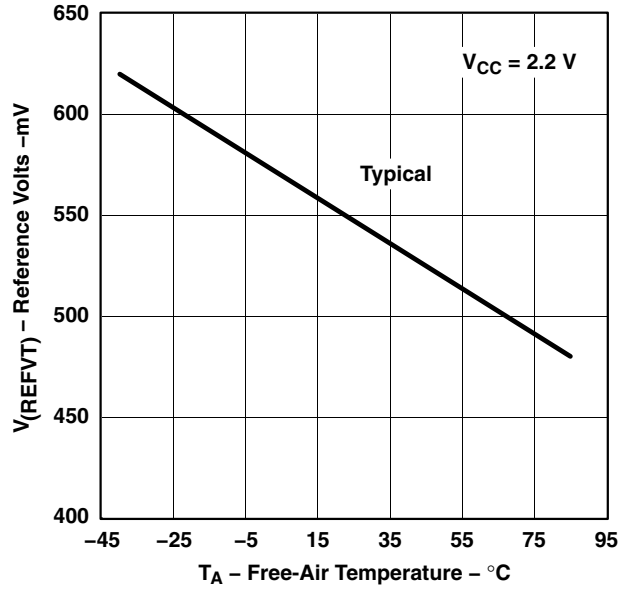

Figure 20.  $V_{(REFVT)}$  vs Temperature,  $V_{CC} = 2.2\text{ V}$

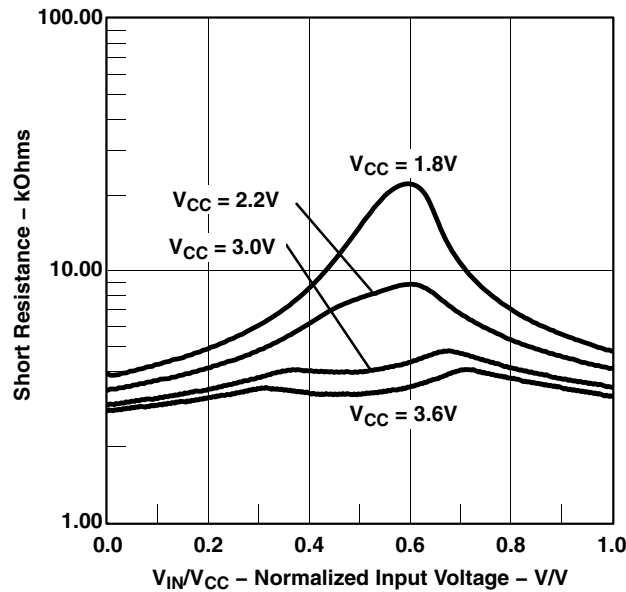

Figure 21. Short Resistance vs  $V_{IN}/V_{CC}$

# MSP430x21x1 MIXED SIGNAL MICROCONTROLLER

SLAS439C – SEPTEMBER 2004 – REVISED JULY 2006

electrical characteristics over recommended ranges of supply voltage and operating free-air temperature (unless otherwise noted) (continued)

## Flash Memory

PARAMETER		TEST CONDITIONS	VCC	MIN	TYP	MAX	UNIT
V <sub>CC(PGM/ERASE)</sub>	Program and Erase supply voltage			2.2		3.6	V
f <sub>FTG</sub>	Flash Timing Generator frequency			257		476	kHz
I <sub>PGM</sub>	Supply current from V <sub>CC</sub> during program		2.2 V/3.6 V		3	5	mA
I <sub>ERASE</sub>	Supply current from V <sub>CC</sub> during erase		2.2 V/3.6 V		3	7	mA
t <sub>CPT</sub>	Cumulative program time (see Note 1)		2.2 V/3.6 V			10	ms
t <sub>CMErase</sub>	Cumulative mass erase time		2.2 V/3.6 V	20			ms
	Program/Erase endurance			10 <sup>4</sup>	10 <sup>5</sup>		cycles
t <sub>Retention</sub>	Data retention duration	T <sub>J</sub> = 25°C		100			years
t <sub>Word</sub>	Word or byte program time	see Note 2			30		t <sub>FTG</sub>
t <sub>Block, 0</sub>	Block program time for 1 <sup>st</sup> byte or word				25		
t <sub>Block, 1-63</sub>	Block program time for each additional byte or word				18		
t <sub>Block, End</sub>	Block program end-sequence wait time				6		
t <sub>Mass Erase</sub>	Mass erase time				10593		
t <sub>Seq Erase</sub>	Segment erase time				4819		

- NOTES: 1. The cumulative program time must not be exceeded when writing to a 64-byte flash block. This parameter applies to all programming methods: individual word/byte write and block write modes.  
2. These values are hardwired into the Flash Controller's state machine (t<sub>FTG</sub> = 1/f<sub>FTG</sub>).

## RAM

PARAMETER		TEST CONDITIONS	VCC	MIN	TYP	MAX	UNIT
V <sub>(RAMh)</sub>	RAM retention supply voltage (see Note 1)	CPU halted		1.6			V

NOTE 1: This parameter defines the minimum supply voltage V<sub>CC</sub> when the data in RAM remains unchanged. No program execution should happen during this supply voltage condition.

## JTAG Interface

PARAMETER		TEST CONDITIONS	VCC	MIN	TYP	MAX	UNIT
f <sub>TCK</sub>	TCK input frequency	see Note 1	2.2 V	0		5	MHz
			3 V	0		10	MHz
R <sub>Internal</sub>	Internal pull-down resistance on TEST		2.2 V/3 V	25	60	90	kΩ

NOTES: 1. f<sub>TCK</sub> may be restricted to meet the timing requirements of the module selected.

## JTAG Fuse (see Note 1)

PARAMETER		TEST CONDITIONS	VCC	MIN	TYP	MAX	UNIT
V <sub>CC(FB)</sub>	Supply voltage during fuse-blow condition	T <sub>A</sub> = 25°C		2.5			V
V <sub>FB</sub>	Voltage level on TEST for fuse-blow	T <sub>A</sub> = 25°C		6		7	V
I <sub>FB</sub>	Supply current into TEST during fuse blow	T <sub>A</sub> = 25°C				100	mA
t <sub>FB</sub>	Time to blow fuse	T <sub>A</sub> = 25°C				1	ms

NOTES: 1. Once the fuse is blown, no further access to the JTAG/Test and emulation feature is possible and is switched to bypass mode.





APPLICATION INFORMATION

Port P1 pin schematic: P1.0 to P1.3, input/output with Schmitt-trigger

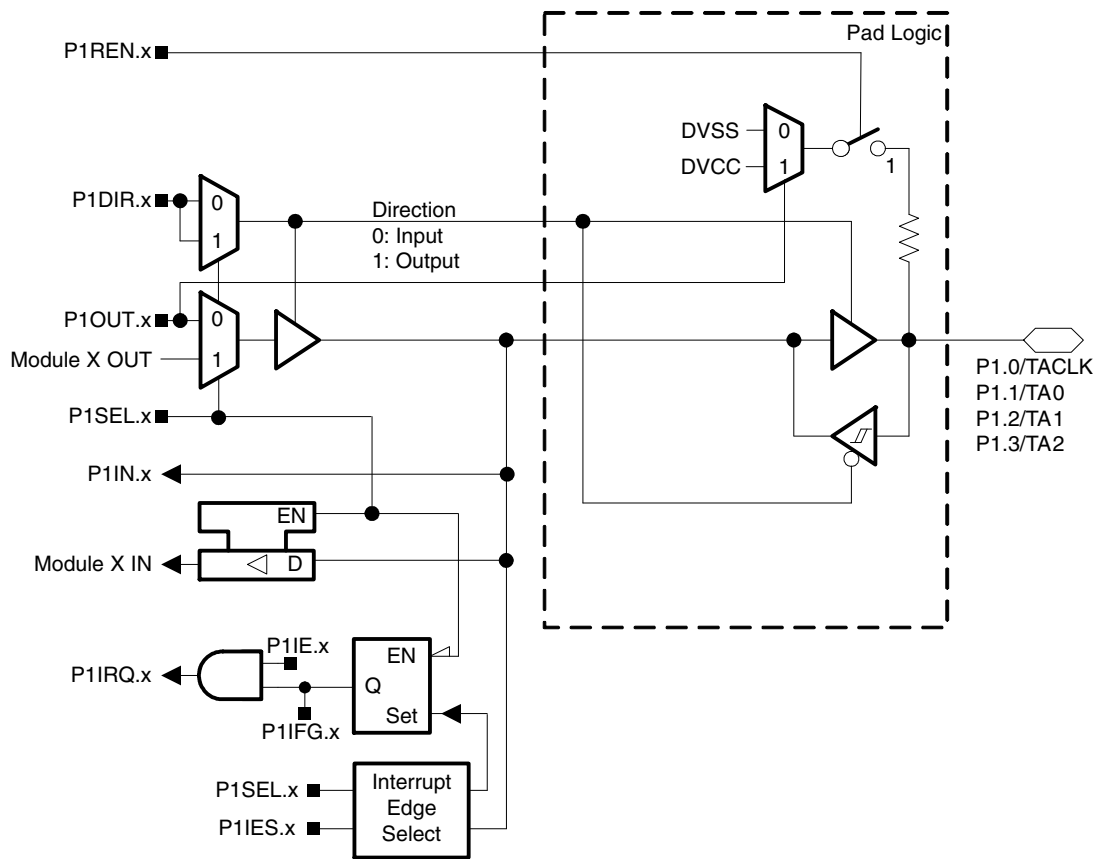

Port P1 (P1.0 to P1.3) pin functions

PIN NAME (P1.X)	X	FUNCTION	CONTROL BITS / SIGNALS	
			P1DIR.x	P1SEL.x
P1.0/TACLK	0	P1.0† (I/O)	I: 0; O: 1	0
		TACLK	0	1
		DVSS	1	1
P1.1/TA0	1	P1.1† (I/O)	I: 0; O: 1	0
		Timer_A3.CCI0A	0	1
		Timer_A3.TA0	1	1
P1.2/TA1	2	P1.2† (I/O)	I: 0; O: 1	0
		Timer_A3.CCI0A	0	1
		Timer_A3.TA0	1	1
P1.3/TA2	3	P1.3† (I/O)	I: 0; O: 1	0
		Timer_A3.CCI0A	0	1
		Timer_A3.TA0	1	1

† Default after reset (PUC/POR)

NOTES: 1. N/A: Not available or not applicable.  
2. X: Don't care.

# MSP430x21x1 MIXED SIGNAL MICROCONTROLLER

SLAS439C – SEPTEMBER 2004 – REVISED JULY 2006

## Port P1 pin schematic: P1.4 to P1.7, input/output with Schmitt-trigger and in-system access features

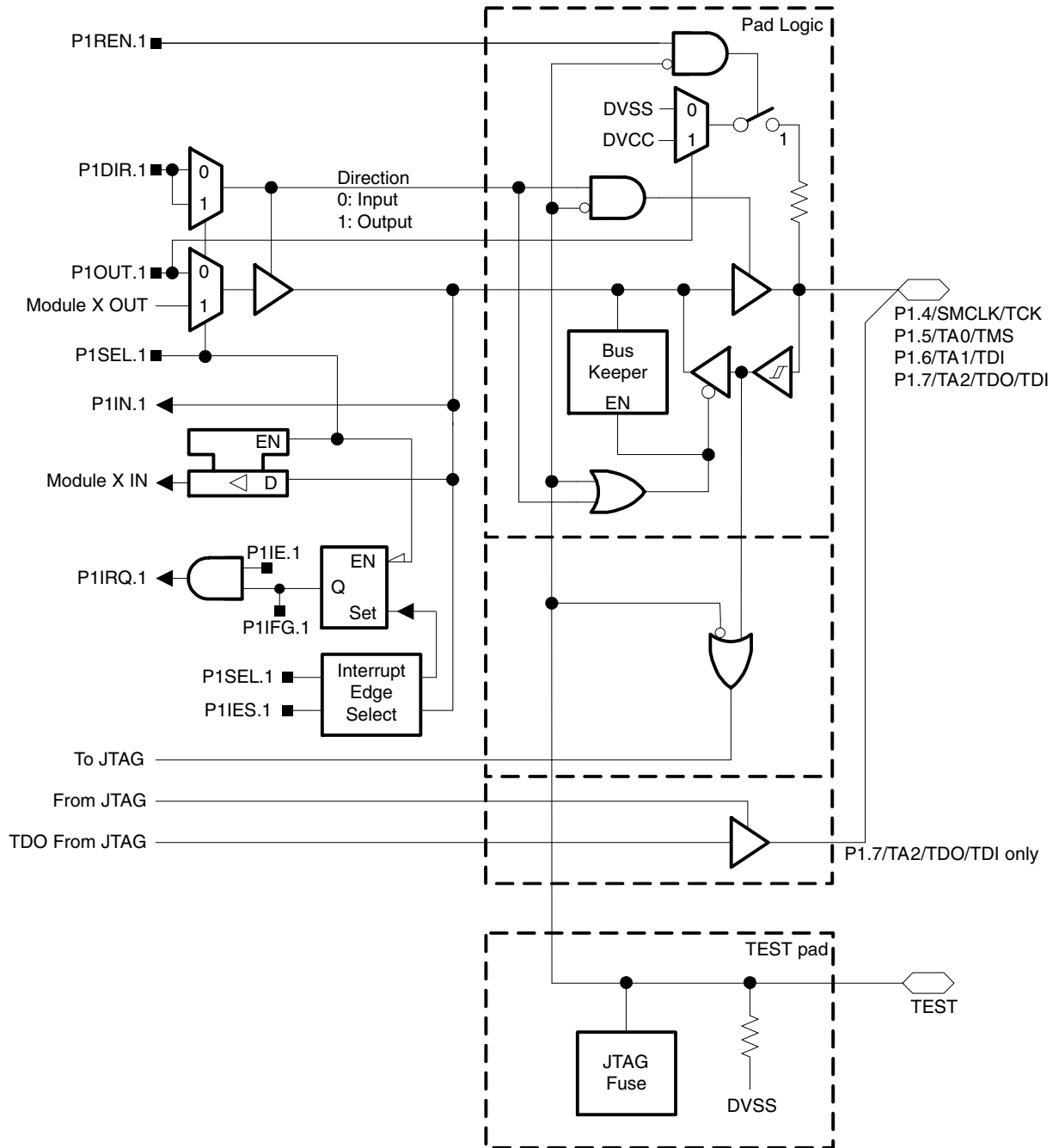

**Port P1 (P1.4 to P1.7) pin functions**

PIN NAME (P1.X)	X	FUNCTION	CONTROL BITS / SIGNALS		
			P1DIR.x	P1SEL.x	TEST
P1.4/SMCLK/TCK	4	P1.4† (I/O)	I: 0; O: 1	0	0
		SMCLK	1	1	0
		TCK	X	X	1
P1.5/TA0/TMS	5	P1.5† (I/O)	I: 0; O: 1	0	0
		Timer_A3.TA0	1	1	0
		TMS	X	X	1
P1.6/TA1/TDI/TCLK	6	P1.6† (I/O)	I: 0; O: 1	0	0
		Timer_A3.TA1	1	1	0
		TDI/TCLK (see Note 3)	X	X	1
P1.7/TA2/TDO/TDI	7	P1.7† (I/O)	I: 0; O: 1	0	0
		Timer_A3.TA2	1	1	0
		TDO/TDI (see Note 3)	X	X	1

† Default after reset (PUC/POR)

- NOTES: 1. N/A: Not available or not applicable.  
 2. X: Don't care.  
 3. Function controlled by JTAG.

# MSP430x21x1 MIXED SIGNAL MICROCONTROLLER

SLAS439C – SEPTEMBER 2004 – REVISED JULY 2006

## Port P2 pin schematic: P2.0 to P2.5, input/output with Schmitt-trigger

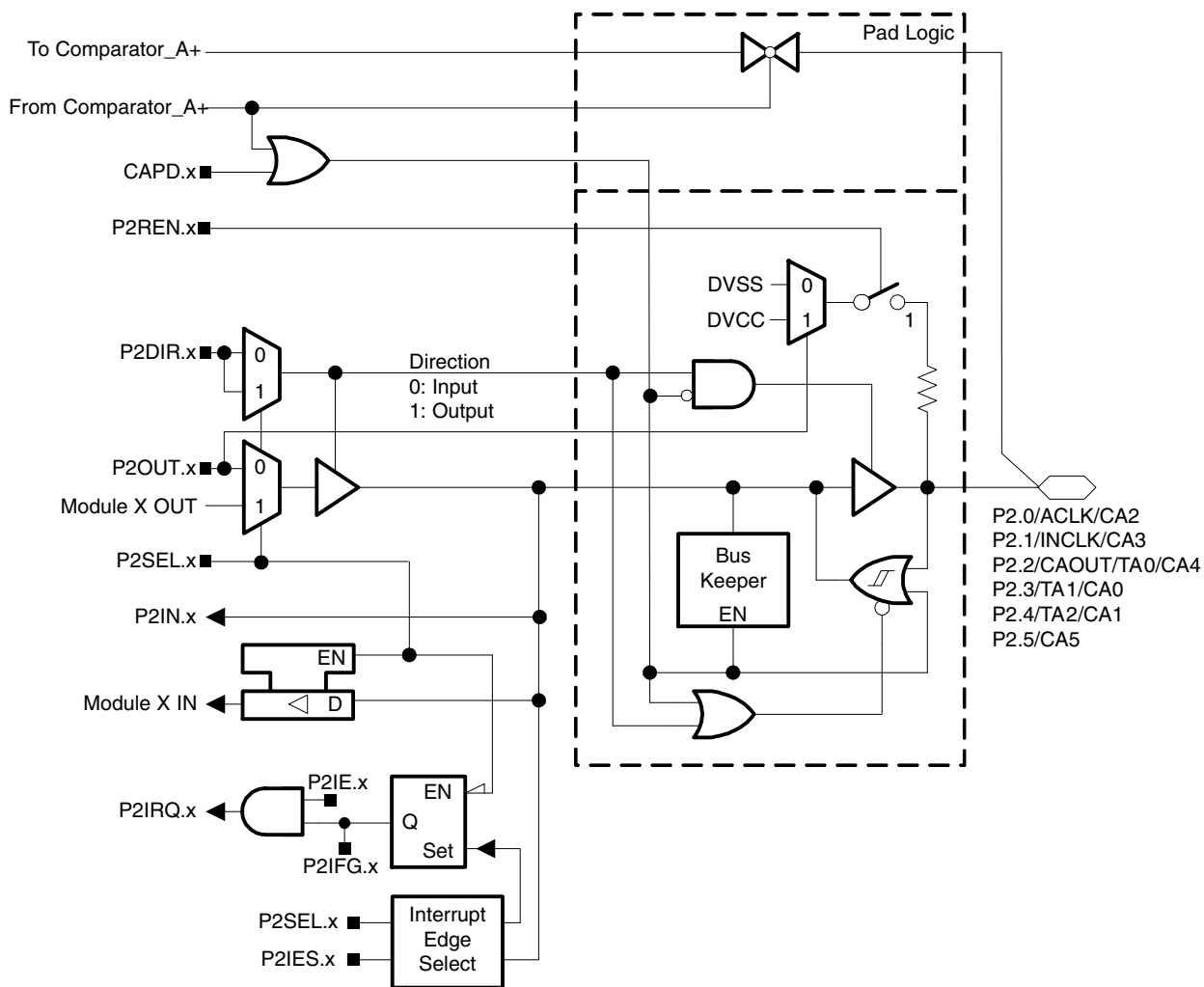

### Control signal “From Comparator\_A+”

PIN NAME	FUNCTION	SIGNAL “FROM COMPARATOR_A+” = 1					
		P2CA4	P2CA0	OR	P2CA3	P2CA2	P2CA1
P2.0/ACLK/CA2	CA2	1	1		0	1	0
P2.1/INCLK/CA3	CA3	N/A	N/A		0	1	1
P2.2/CAOUT/TA0/CA4	CA4	N/A	N/A		1	0	0
P2.3/TA1/CA0	CA0	0	1		N/A	N/A	N/A
P2.4/TA2/CA1	CA1	1	0		0	0	1
P2.5/CA5	CA5	N/A	N/A	1	0	1	

NOTES: 1. N/A: Not available or not applicable.

**Port P2 (P2.0 to P2.5) pin functions**

PIN NAME (P2.X)	X	FUNCTION	CONTROL BITS / SIGNALS		
			P2DIR.x	P2SEL.x	CAPD.x
P2.0/ACLK/CA2	0	P2.0† (I/O)	I: 0; O: 1	0	0
		ACLK	1	1	0
		CA2 (see Note 3)	X	X	1
P2.1/INCLK/CA3	1	P2.1† (I/O)	I: 0; O: 1	0	0
		Timer_A3.INCLK	0	1	0
		DV <sub>SS</sub>	1	1	0
		CA3 (see Note 3)	X	X	1
P2.2/CAOUT/TA0/CA4	2	P2.2† (I/O)	I: 0; O: 1	0	0
		Timer_A3.CCI0B	0	1	0
		CAOUT	1	1	0
		CA4 (see Note 3)	X	X	1
P2.3/TA1/CA0	3	P2.3† (I/O)	I: 0; O: 1	0	0
		Timer_A3.TA1	1	1	0
		CA0 (see Note 3)	X	X	1
P2.4/TA2/CA1	4	P2.4† (I/O)	I: 0; O: 1	0	0
		Timer_A3.TA2	1	1	0
		CA1 (see Note 3)	X	X	1
P2.5/CA5	5	P2.5† (I/O)	I: 0; O: 1	0	0
		CA5 (see Note 3)	X	X	1

† Default after reset (PUC/POR)

- NOTES:
1. N/A: Not available or not applicable.
  2. X: Don't care.
  3. Setting the CAPD.x bit disables the output driver as well as the input Schmitt trigger to prevent parasitic cross currents when applying analog signals. Selecting the CAx input pin to the comparator multiplexer with the P2CAx bits automatically disables the input buffer for that pin, regardless of the state of the associated CAPD.x bit.

# MSP430x21x1 MIXED SIGNAL MICROCONTROLLER

SLAS439C – SEPTEMBER 2004 – REVISED JULY 2006

## Port P2 pin schematic: P2.6, input/output with Schmitt-trigger and crystal oscillator input

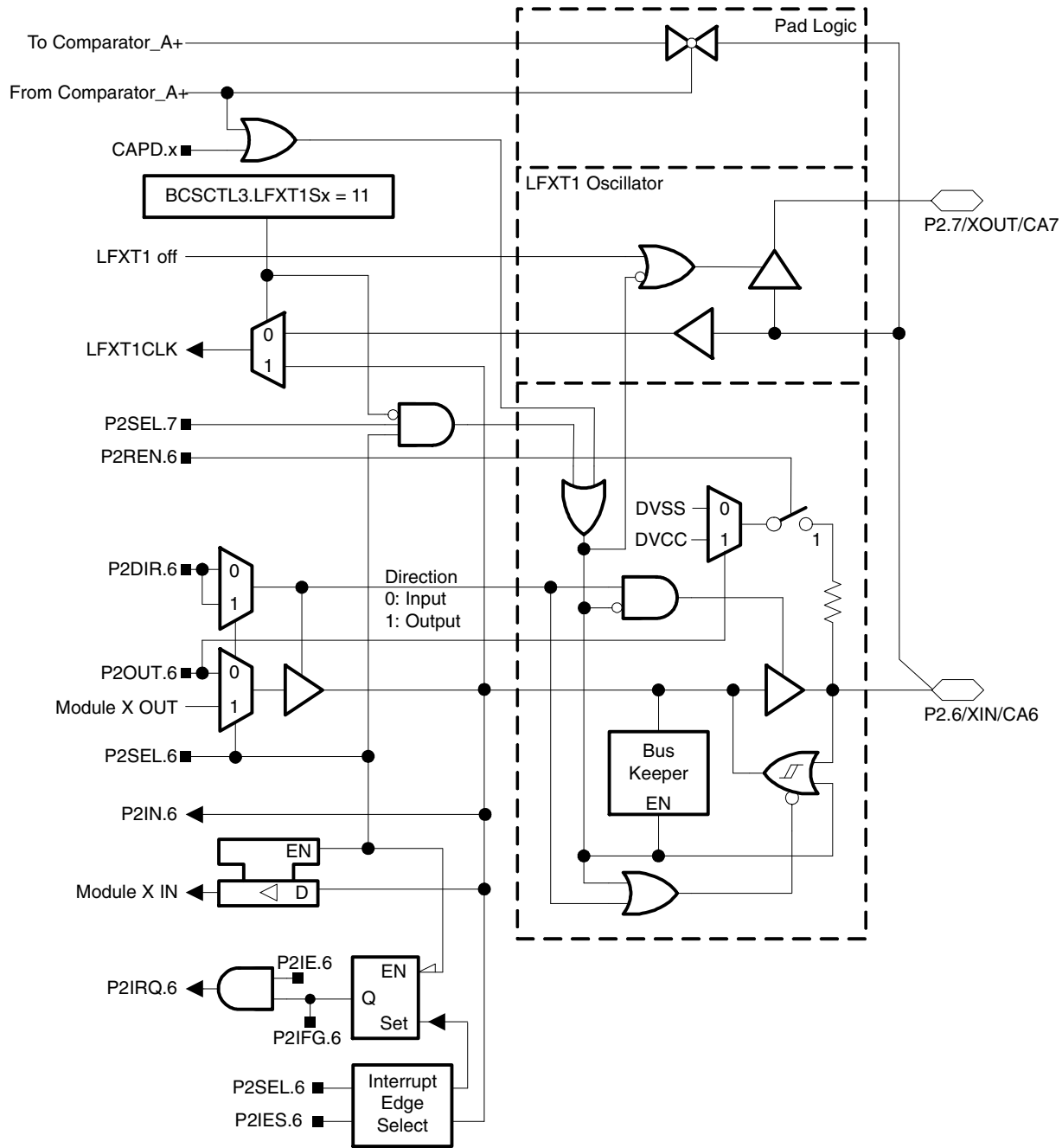

### Control signal "From Comparator\_A+"

PIN NAME	FUNCTION	SIGNAL "FROM COMPARATOR_A+" = 1		
		P2CA3	P2CA2	P2CA1
P2.6/XIN/CA6	CA6	1	1	0

## Port P2 pin schematic: P2.7, input/output with Schmitt-trigger and crystal oscillator output

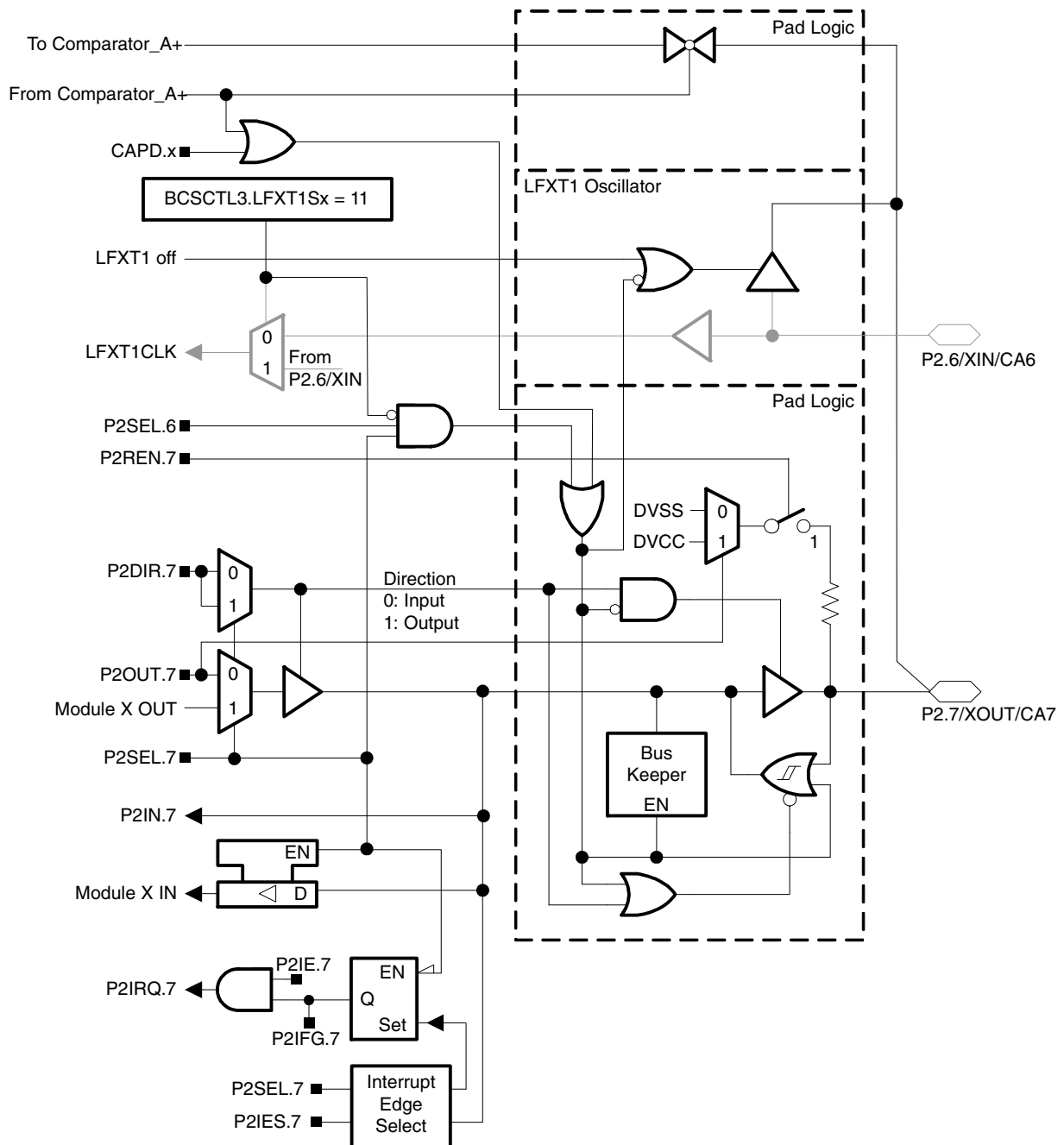

### Control signal "From Comparator\_A+"

PIN NAME	FUNCTION	SIGNAL "FROM COMPARATOR_A+" = 1		
		P2CA3	P2CA2	P2CA1
P2.7/XOUT/CA7	CA7	1	1	1

# MSP430x21x1 MIXED SIGNAL MICROCONTROLLER

SLAS439C – SEPTEMBER 2004 – REVISED JULY 2006

## Port P2 (P2.6) pin functions

PIN NAME (P2.X)	X	FUNCTION	CONTROL BITS / SIGNALS		
			P2DIR.x	P2SEL.x	CAPD.x
P2.6/XIN/CA6	6	P2.6 (I/O)	I: 0; O: 1	0	0
		XIN†	X	1	0
		CA6 (see Note 3)	X	X	1

† Default after reset (PUC/POR)

NOTES: 1. N/A: Not available or not applicable.

2. X: Don't care.

3. Setting the CAPD.x bit disables the output driver as well as the input Schmitt trigger to prevent parasitic cross currents when applying analog signals. Selecting the CAx input pin to the comparator multiplexer with the P2CAx bits automatically disables the input buffer for that pin, regardless of the state of the associated CAPDx bit.

## Port P2 (P2.7) pin functions

PIN NAME (P2.X)	X	FUNCTION	CONTROL BITS / SIGNALS		
			P2DIR.x	P2SEL.x	CAPD.x
P2.7/XOUT/CA7	6	P2.7 (I/O)	I: 0; O: 1	0	0
		XOUT† (see Note 4)	X	1	0
		CA7 (see Note 3)	X	X	1

† Default after reset (PUC/POR)

NOTES: 1. N/A: Not available or not applicable.

2. X: Don't care.

3. Setting the CAPD.x bit disables the output driver as well as the input Schmitt trigger to prevent parasitic cross currents when applying analog signals. Selecting the CAx input pin to the comparator multiplexer with the P2CAx bits automatically disables the input buffer for that pin, regardless of the state of the associated CAPD.x bit.

4. If the pin XOUT/P2.7/CA7 is used as an input a current can flow until P2SEL.7 is cleared due to the oscillator output driver connection to this pin after reset.





## JTAG fuse check mode

MSP430 devices that have the fuse on the TEST terminal have a fuse check mode that tests the continuity of the fuse the first time the JTAG port is accessed after a power-on reset (POR). When activated, a fuse check current,  $I_{TF}$ , of 1 mA at 3 V, 2.5 mA at 5 V can flow from the TEST pin to ground if the fuse is not burned. Care must be taken to avoid accidentally activating the fuse check mode and increasing overall system power consumption.

When the TEST pin is again taken low after a test or programming session, the fuse check mode and sense currents are terminated.

Activation of the fuse check mode occurs with the first negative edge on the TMS pin after power up or if TMS is being held low during power up. The second positive edge on the TMS pin deactivates the fuse check mode. After deactivation, the fuse check mode remains inactive until another POR occurs. After each POR the fuse check mode has the potential to be activated.

The fuse check current will only flow when the fuse check mode is active and the TMS pin is in a low state (see Figure 22). Therefore, the additional current flow can be prevented by holding the TMS pin high (default condition).

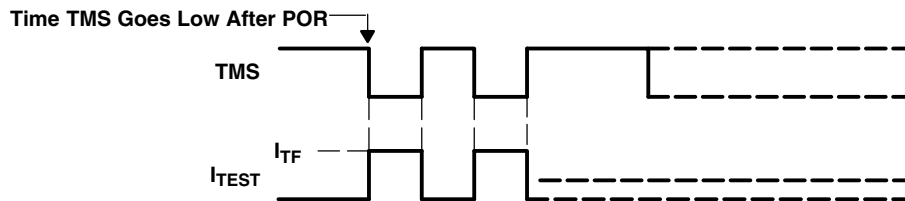

Figure 22. Fuse Check Mode Current, MSP430F21x1

**NOTE:**

The CODE and RAM data protection is ensured if the JTAG fuse is blown and the 256-bit bootloader access key is used. Also, see the *bootstrap loader* section for more information.

# MSP430x21x1 MIXED SIGNAL MICROCONTROLLER

SLAS439C – SEPTEMBER 2004 – REVISED JULY 2006

## Data Sheet Revision History

Literature Number	Summary
SLAS439	Preliminary PRODUCT PREVIEW datasheet release.
SLAS439A	MSP430x21x1 production datasheet release.
SLAS439B	Corrected instruction cycle time to 62.5ns, pg 1 Updated Figure 1. Operating Area, pg 12 Updated Figures 2 & 3, pg 13 R <sub>PULL</sub> unit corrected from "Ω" to "kΩ", pg 15 Max load current specification and Note 3 removed from "outputs" table, pg 16 MIN and MAX percentages for "calibrated DCO frequencies – tolerance over supply voltage VCC" corrected from 2.5% to 3% to match the specified frequency ranges., pg 22
SLAS439C	MSP430x21x1T production datasheet release. 105°C characterization results added.

NOTE: The referring page and figure numbers are referred to the respective document revision.



**PACKAGING INFORMATION**

Orderable Device	Status <sup>(1)</sup>	Package Type	Package Drawing	Pins	Package Qty	Eco Plan <sup>(2)</sup>	Lead/Ball Finish	MSL Peak Temp <sup>(3)</sup>
MSP430F2101IDGV	ACTIVE	TVSOP	DGV	20	90	Green (RoHS & no Sb/Br)	CU NIPDAU	Level-2-260C-1 YEAR
MSP430F2101IDGVR	ACTIVE	TVSOP	DGV	20	2000	Green (RoHS & no Sb/Br)	CU NIPDAU	Level-2-260C-1 YEAR
MSP430F2101IDW	ACTIVE	SOIC	DW	20	25	Green (RoHS & no Sb/Br)	CU NIPDAU	Level-1-260C-UNLIM
MSP430F2101IDWR	ACTIVE	SOIC	DW	20	2000	Green (RoHS & no Sb/Br)	CU NIPDAU	Level-1-260C-UNLIM
MSP430F2101IPW	ACTIVE	TSSOP	PW	20	70	Green (RoHS & no Sb/Br)	CU NIPDAU	Level-1-260C-UNLIM
MSP430F2101IPWR	ACTIVE	TSSOP	PW	20	2000	Green (RoHS & no Sb/Br)	CU NIPDAU	Level-1-260C-UNLIM
MSP430F2101IRGER	ACTIVE	VQFN	RGE	24	3000	Green (RoHS & no Sb/Br)	CU NIPDAU	Level-2-260C-1 YEAR
MSP430F2101IRGET	ACTIVE	VQFN	RGE	24	250	Green (RoHS & no Sb/Br)	CU NIPDAU	Level-2-260C-1 YEAR
MSP430F2101TDGV	ACTIVE	TVSOP	DGV	20	90	Green (RoHS & no Sb/Br)	CU NIPDAU	Level-2-260C-1 YEAR
MSP430F2101TDGVR	ACTIVE	TVSOP	DGV	20	2000	Green (RoHS & no Sb/Br)	CU NIPDAU	Level-2-260C-1 YEAR
MSP430F2101TDW	ACTIVE	SOIC	DW	20	25	Green (RoHS & no Sb/Br)	CU NIPDAU	Level-1-260C-UNLIM
MSP430F2101TDWR	ACTIVE	SOIC	DW	20	2000	Green (RoHS & no Sb/Br)	CU NIPDAU	Level-1-260C-UNLIM
MSP430F2101TPW	ACTIVE	TSSOP	PW	20	70	Green (RoHS & no Sb/Br)	CU NIPDAU	Level-1-260C-UNLIM
MSP430F2101TPWR	ACTIVE	TSSOP	PW	20	2000	Green (RoHS & no Sb/Br)	CU NIPDAU	Level-1-260C-UNLIM
MSP430F2101TRGER	ACTIVE	VQFN	RGE	24	3000	Green (RoHS & no Sb/Br)	CU NIPDAU	Level-2-260C-1 YEAR
MSP430F2101TRGET	ACTIVE	VQFN	RGE	24	250	Green (RoHS & no Sb/Br)	CU NIPDAU	Level-2-260C-1 YEAR
MSP430F2111IDGV	ACTIVE	TVSOP	DGV	20	90	Green (RoHS & no Sb/Br)	CU NIPDAU	Level-2-260C-1 YEAR
MSP430F2111IDGVR	ACTIVE	TVSOP	DGV	20	2000	Green (RoHS & no Sb/Br)	CU NIPDAU	Level-2-260C-1 YEAR
MSP430F2111IDW	ACTIVE	SOIC	DW	20	25	Green (RoHS & no Sb/Br)	CU NIPDAU	Level-1-260C-UNLIM
MSP430F2111IDWR	ACTIVE	SOIC	DW	20	2000	Green (RoHS & no Sb/Br)	CU NIPDAU	Level-1-260C-UNLIM
MSP430F2111IPW	ACTIVE	TSSOP	PW	20	70	Green (RoHS & no Sb/Br)	CU NIPDAU	Level-1-260C-UNLIM
MSP430F2111IPWR	ACTIVE	TSSOP	PW	20	2000	Green (RoHS & no Sb/Br)	CU NIPDAU	Level-1-260C-UNLIM
MSP430F2111IRGER	ACTIVE	VQFN	RGE	24	3000	Green (RoHS & no Sb/Br)	CU NIPDAU	Level-2-260C-1 YEAR
MSP430F2111IRGET	ACTIVE	VQFN	RGE	24	250	Green (RoHS & no Sb/Br)	CU NIPDAU	Level-2-260C-1 YEAR
MSP430F2111TDGV	ACTIVE	TVSOP	DGV	20	90	Green (RoHS & no Sb/Br)	CU NIPDAU	Level-2-260C-1 YEAR

Orderable Device	Status <sup>(1)</sup>	Package Type	Package Drawing	Pins	Package Qty	Eco Plan <sup>(2)</sup>	Lead/Ball Finish	MSL Peak Temp <sup>(3)</sup>
MSP430F2111TDGVR	ACTIVE	TVSOP	DGV	20	2000	Green (RoHS & no Sb/Br)	CU NIPDAU	Level-2-260C-1 YEAR
MSP430F2111TDW	ACTIVE	SOIC	DW	20	25	Green (RoHS & no Sb/Br)	CU NIPDAU	Level-1-260C-UNLIM
MSP430F2111TDWR	ACTIVE	SOIC	DW	20	2000	Green (RoHS & no Sb/Br)	CU NIPDAU	Level-1-260C-UNLIM
MSP430F2111TPW	ACTIVE	TSSOP	PW	20	70	Green (RoHS & no Sb/Br)	CU NIPDAU	Level-1-260C-UNLIM
MSP430F2111TPWR	ACTIVE	TSSOP	PW	20	2000	Green (RoHS & no Sb/Br)	CU NIPDAU	Level-1-260C-UNLIM
MSP430F2111TRGER	ACTIVE	VQFN	RGE	24	3000	Green (RoHS & no Sb/Br)	CU NIPDAU	Level-2-260C-1 YEAR
MSP430F2111TRGET	ACTIVE	VQFN	RGE	24	250	Green (RoHS & no Sb/Br)	CU NIPDAU	Level-2-260C-1 YEAR
MSP430F2121IDGV	ACTIVE	TVSOP	DGV	20	90	Green (RoHS & no Sb/Br)	CU NIPDAU	Level-2-260C-1 YEAR
MSP430F2121IDGVR	ACTIVE	TVSOP	DGV	20	2000	Green (RoHS & no Sb/Br)	CU NIPDAU	Level-2-260C-1 YEAR
MSP430F2121IDW	ACTIVE	SOIC	DW	20	25	Green (RoHS & no Sb/Br)	CU NIPDAU	Level-1-260C-UNLIM
MSP430F2121IDWR	ACTIVE	SOIC	DW	20	2000	Green (RoHS & no Sb/Br)	CU NIPDAU	Level-1-260C-UNLIM
MSP430F2121IPW	ACTIVE	TSSOP	PW	20	70	Green (RoHS & no Sb/Br)	CU NIPDAU	Level-1-260C-UNLIM
MSP430F2121IPWR	ACTIVE	TSSOP	PW	20	2000	Green (RoHS & no Sb/Br)	CU NIPDAU	Level-1-260C-UNLIM
MSP430F2121IRGER	ACTIVE	VQFN	RGE	24	3000	Green (RoHS & no Sb/Br)	CU NIPDAU	Level-2-260C-1 YEAR
MSP430F2121IRGET	ACTIVE	VQFN	RGE	24	250	Green (RoHS & no Sb/Br)	CU NIPDAU	Level-2-260C-1 YEAR
MSP430F2121TDGV	ACTIVE	TVSOP	DGV	20	90	Green (RoHS & no Sb/Br)	CU NIPDAU	Level-2-260C-1 YEAR
MSP430F2121TDGVR	ACTIVE	TVSOP	DGV	20	2000	Green (RoHS & no Sb/Br)	CU NIPDAU	Level-2-260C-1 YEAR
MSP430F2121TDW	ACTIVE	SOIC	DW	20	25	Green (RoHS & no Sb/Br)	CU NIPDAU	Level-1-260C-UNLIM
MSP430F2121TDWR	ACTIVE	SOIC	DW	20	2000	Green (RoHS & no Sb/Br)	CU NIPDAU	Level-1-260C-UNLIM
MSP430F2121TPW	ACTIVE	TSSOP	PW	20	70	Green (RoHS & no Sb/Br)	CU NIPDAU	Level-1-260C-UNLIM
MSP430F2121TPWR	ACTIVE	TSSOP	PW	20	2000	Green (RoHS & no Sb/Br)	CU NIPDAU	Level-1-260C-UNLIM
MSP430F2121TRGER	ACTIVE	VQFN	RGE	24	3000	Green (RoHS & no Sb/Br)	CU NIPDAU	Level-2-260C-1 YEAR
MSP430F2121TRGET	ACTIVE	VQFN	RGE	24	250	Green (RoHS & no Sb/Br)	CU NIPDAU	Level-2-260C-1 YEAR
MSP430F2131IDGV	ACTIVE	TVSOP	DGV	20	90	Green (RoHS & no Sb/Br)	CU NIPDAU	Level-2-260C-1 YEAR
MSP430F2131IDGVR	ACTIVE	TVSOP	DGV	20	2000	Green (RoHS & no Sb/Br)	CU NIPDAU	Level-2-260C-1 YEAR
MSP430F2131IDW	ACTIVE	SOIC	DW	20	25	Green (RoHS & no Sb/Br)	CU NIPDAU	Level-1-260C-UNLIM

Orderable Device	Status <sup>(1)</sup>	Package Type	Package Drawing	Pins	Package Qty	Eco Plan <sup>(2)</sup>	Lead/Ball Finish	MSL Peak Temp <sup>(3)</sup>
MSP430F2131IDWR	ACTIVE	SOIC	DW	20	2000	Green (RoHS & no Sb/Br)	CU NIPDAU	Level-1-260C-UNLIM
MSP430F2131IPW	ACTIVE	TSSOP	PW	20	70	Green (RoHS & no Sb/Br)	CU NIPDAU	Level-1-260C-UNLIM
MSP430F2131IPWR	ACTIVE	TSSOP	PW	20	2000	Green (RoHS & no Sb/Br)	CU NIPDAU	Level-1-260C-UNLIM
MSP430F2131IRGER	ACTIVE	VQFN	RGE	24	3000	Green (RoHS & no Sb/Br)	CU NIPDAU	Level-2-260C-1 YEAR
MSP430F2131IRGET	ACTIVE	VQFN	RGE	24	250	Green (RoHS & no Sb/Br)	CU NIPDAU	Level-2-260C-1 YEAR
MSP430F2131TDGV	ACTIVE	TVSOP	DGV	20	90	Green (RoHS & no Sb/Br)	CU NIPDAU	Level-2-260C-1 YEAR
MSP430F2131TDGVR	ACTIVE	TVSOP	DGV	20	2000	Green (RoHS & no Sb/Br)	CU NIPDAU	Level-2-260C-1 YEAR
MSP430F2131TDW	ACTIVE	SOIC	DW	20	25	Green (RoHS & no Sb/Br)	CU NIPDAU	Level-1-260C-UNLIM
MSP430F2131TDWR	ACTIVE	SOIC	DW	20	2000	Green (RoHS & no Sb/Br)	CU NIPDAU	Level-1-260C-UNLIM
MSP430F2131TPW	ACTIVE	TSSOP	PW	20	70	Green (RoHS & no Sb/Br)	CU NIPDAU	Level-1-260C-UNLIM
MSP430F2131TPWR	ACTIVE	TSSOP	PW	20	2000	Green (RoHS & no Sb/Br)	CU NIPDAU	Level-1-260C-UNLIM
MSP430F2131TRGER	ACTIVE	VQFN	RGE	24	3000	Green (RoHS & no Sb/Br)	CU NIPDAU	Level-2-260C-1 YEAR
MSP430F2131TRGET	ACTIVE	VQFN	RGE	24	250	Green (RoHS & no Sb/Br)	CU NIPDAU	Level-2-260C-1 YEAR

<sup>(1)</sup> The marketing status values are defined as follows:

**ACTIVE:** Product device recommended for new designs.

**LIFEBUY:** TI has announced that the device will be discontinued, and a lifetime-buy period is in effect.

**NRND:** Not recommended for new designs. Device is in production to support existing customers, but TI does not recommend using this part in a new design.

**PREVIEW:** Device has been announced but is not in production. Samples may or may not be available.

**OBSOLETE:** TI has discontinued the production of the device.

<sup>(2)</sup> Eco Plan - The planned eco-friendly classification: Pb-Free (RoHS), Pb-Free (RoHS Exempt), or Green (RoHS & no Sb/Br) - please check <http://www.ti.com/productcontent> for the latest availability information and additional product content details.

**TBD:** The Pb-Free/Green conversion plan has not been defined.

**Pb-Free (RoHS):** TI's terms "Lead-Free" or "Pb-Free" mean semiconductor products that are compatible with the current RoHS requirements for all 6 substances, including the requirement that lead not exceed 0.1% by weight in homogeneous materials. Where designed to be soldered at high temperatures, TI Pb-Free products are suitable for use in specified lead-free processes.

**Pb-Free (RoHS Exempt):** This component has a RoHS exemption for either 1) lead-based flip-chip solder bumps used between the die and package, or 2) lead-based die adhesive used between the die and leadframe. The component is otherwise considered Pb-Free (RoHS compatible) as defined above.

**Green (RoHS & no Sb/Br):** TI defines "Green" to mean Pb-Free (RoHS compatible), and free of Bromine (Br) and Antimony (Sb) based flame retardants (Br or Sb do not exceed 0.1% by weight in homogeneous material)

<sup>(3)</sup> MSL, Peak Temp. -- The Moisture Sensitivity Level rating according to the JEDEC industry standard classifications, and peak solder temperature.

**Important Information and Disclaimer:** The information provided on this page represents TI's knowledge and belief as of the date that it is provided. TI bases its knowledge and belief on information provided by third parties, and makes no representation or warranty as to the accuracy of such information. Efforts are underway to better integrate information from third parties. TI has taken and continues to take reasonable steps to provide representative and accurate information but may not have conducted destructive testing or chemical analysis on incoming materials and chemicals. TI and TI suppliers consider certain information to be proprietary, and thus CAS numbers and other limited information may not be available for release.

In no event shall TI's liability arising out of such information exceed the total purchase price of the TI part(s) at issue in this document sold by TI to Customer on an annual basis.

DW (R-PDSO-G20)

PLASTIC SMALL-OUTLINE PACKAGE



- NOTES:
- A. All linear dimensions are in inches (millimeters).
  - B. This drawing is subject to change without notice.
  - C. Body dimensions do not include mold flash or protrusion not to exceed 0.006 (0,15).
  - D. Falls within JEDEC MS-013 variation AC.

RGE (S-PVQFN-N24)

PLASTIC QUAD FLATPACK NO-LEAD

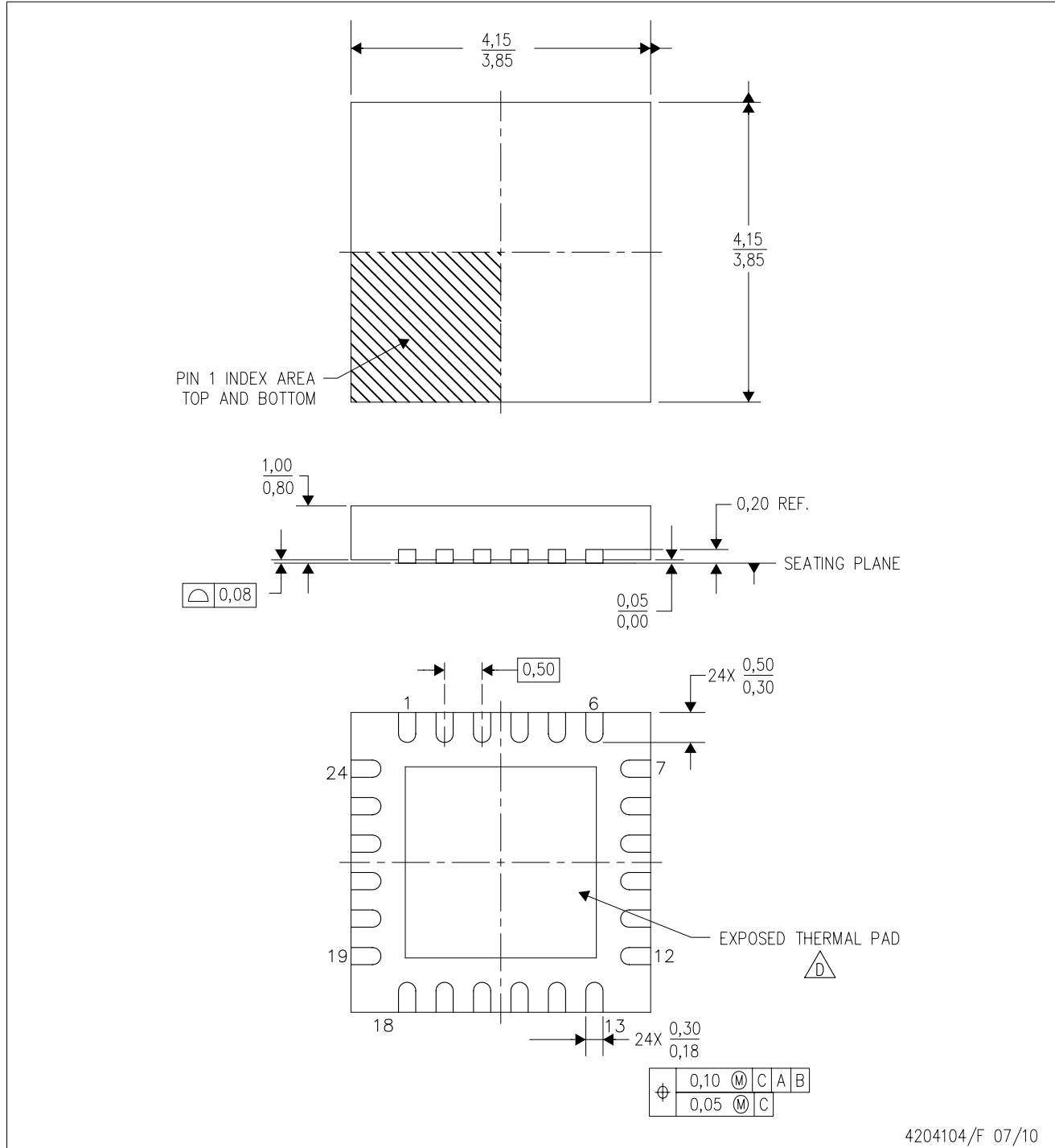

4204104/F 07/10

- NOTES:
- A. All linear dimensions are in millimeters. Dimensioning and tolerancing per ASME Y14.5M-1994.
  - B. This drawing is subject to change without notice.
  - C. Quad Flatpack, No-Leads (QFN) package configuration.
  -  The package thermal pad must be soldered to the board for thermal and mechanical performance. See the Product Data Sheet for details regarding the exposed thermal pad dimensions.
  - E. Falls within JEDEC MO-220.



## THERMAL PAD MECHANICAL DATA

RGE (S-PVQFN-N24)

PLASTIC QUAD FLATPACK NO-LEAD

### THERMAL INFORMATION

This package incorporates an exposed thermal pad that is designed to be attached directly to an external heatsink. The thermal pad must be soldered directly to the printed circuit board (PCB). After soldering, the PCB can be used as a heatsink. In addition, through the use of thermal vias, the thermal pad can be attached directly to the appropriate copper plane shown in the electrical schematic for the device, or alternatively, can be attached to a special heatsink structure designed into the PCB. This design optimizes the heat transfer from the integrated circuit (IC).

For information on the Quad Flatpack No-Lead (QFN) package and its advantages, refer to Application Report, QFN/SON PCB Attachment, Texas Instruments Literature No. SLUA271. This document is available at [www.ti.com](http://www.ti.com).

The exposed thermal pad dimensions for this package are shown in the following illustration.

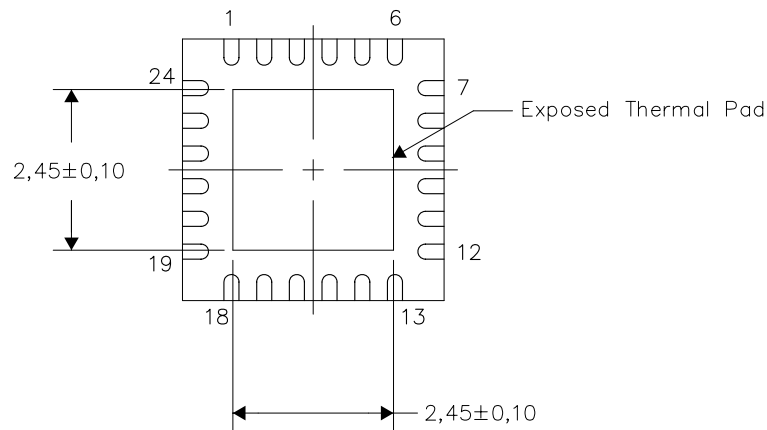

Bottom View

Exposed Thermal Pad Dimensions

#### NOTES:

- 1) All linear dimensions are in millimeters

RGE (S-PVQFN-N24)

PLASTIC QUAD FLATPACK NO-LEAD

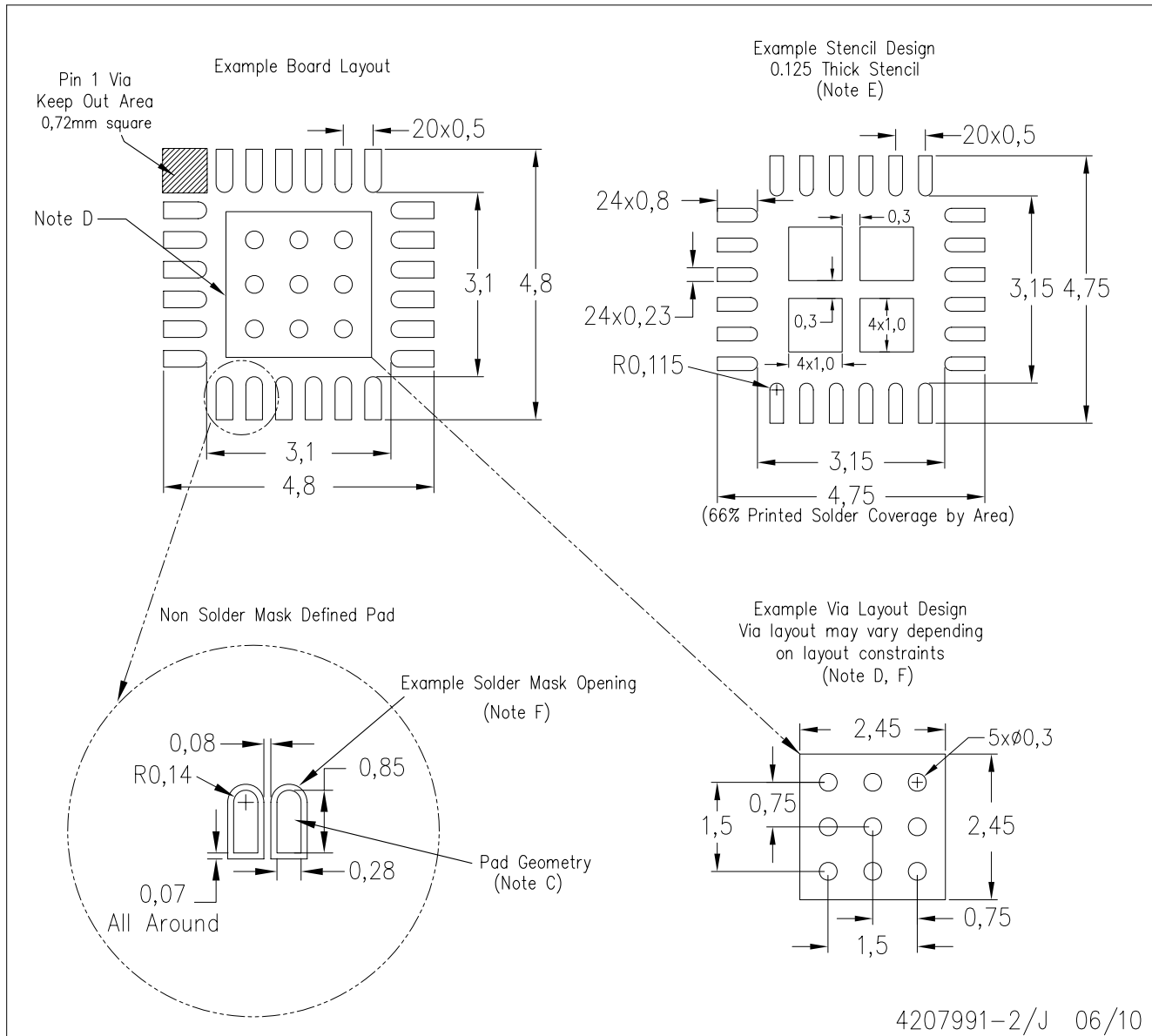

- NOTES:
- All linear dimensions are in millimeters.
  - This drawing is subject to change without notice.
  - Publication IPC-7351 is recommended for alternate designs.
  - This package is designed to be soldered to a thermal pad on the board. Refer to Application Note, Quad Flat-Pack Packages, Texas Instruments Literature No. SLUA271, and also the Product Data Sheets for specific thermal information, via requirements, and recommended board layout. These documents are available at [www.ti.com](http://www.ti.com) <<http://www.ti.com>>.
  - Laser cutting apertures with trapezoidal walls and also rounding corners will offer better paste release. Customers should contact their board assembly site for stencil design recommendations. Refer to IPC 7525 for stencil design considerations.
  - Customers should contact their board fabrication site for recommended solder mask tolerances and via tenting recommendations for vias placed in the thermal pad.

PW (R-PDSO-G\*\*)

PLASTIC SMALL-OUTLINE PACKAGE

14 PINS SHOWN



4040064/F 01/97

- NOTES: A. All linear dimensions are in millimeters.  
 B. This drawing is subject to change without notice.  
 C. Body dimensions do not include mold flash or protrusion not to exceed 0,15.  
 D. Falls within JEDEC MO-153

## IMPORTANT NOTICE

Texas Instruments Incorporated and its subsidiaries (TI) reserve the right to make corrections, modifications, enhancements, improvements, and other changes to its products and services at any time and to discontinue any product or service without notice. Customers should obtain the latest relevant information before placing orders and should verify that such information is current and complete. All products are sold subject to TI's terms and conditions of sale supplied at the time of order acknowledgment.

TI warrants performance of its hardware products to the specifications applicable at the time of sale in accordance with TI's standard warranty. Testing and other quality control techniques are used to the extent TI deems necessary to support this warranty. Except where mandated by government requirements, testing of all parameters of each product is not necessarily performed.

TI assumes no liability for applications assistance or customer product design. Customers are responsible for their products and applications using TI components. To minimize the risks associated with customer products and applications, customers should provide adequate design and operating safeguards.

TI does not warrant or represent that any license, either express or implied, is granted under any TI patent right, copyright, mask work right, or other TI intellectual property right relating to any combination, machine, or process in which TI products or services are used. Information published by TI regarding third-party products or services does not constitute a license from TI to use such products or services or a warranty or endorsement thereof. Use of such information may require a license from a third party under the patents or other intellectual property of the third party, or a license from TI under the patents or other intellectual property of TI.

Reproduction of TI information in TI data books or data sheets is permissible only if reproduction is without alteration and is accompanied by all associated warranties, conditions, limitations, and notices. Reproduction of this information with alteration is an unfair and deceptive business practice. TI is not responsible or liable for such altered documentation. Information of third parties may be subject to additional restrictions.

Resale of TI products or services with statements different from or beyond the parameters stated by TI for that product or service voids all express and any implied warranties for the associated TI product or service and is an unfair and deceptive business practice. TI is not responsible or liable for any such statements.

TI products are not authorized for use in safety-critical applications (such as life support) where a failure of the TI product would reasonably be expected to cause severe personal injury or death, unless officers of the parties have executed an agreement specifically governing such use. Buyers represent that they have all necessary expertise in the safety and regulatory ramifications of their applications, and acknowledge and agree that they are solely responsible for all legal, regulatory and safety-related requirements concerning their products and any use of TI products in such safety-critical applications, notwithstanding any applications-related information or support that may be provided by TI. Further, Buyers must fully indemnify TI and its representatives against any damages arising out of the use of TI products in such safety-critical applications.

TI products are neither designed nor intended for use in military/aerospace applications or environments unless the TI products are specifically designated by TI as military-grade or "enhanced plastic." Only products designated by TI as military-grade meet military specifications. Buyers acknowledge and agree that any such use of TI products which TI has not designated as military-grade is solely at the Buyer's risk, and that they are solely responsible for compliance with all legal and regulatory requirements in connection with such use.

TI products are neither designed nor intended for use in automotive applications or environments unless the specific TI products are designated by TI as compliant with ISO/TS 16949 requirements. Buyers acknowledge and agree that, if they use any non-designated products in automotive applications, TI will not be responsible for any failure to meet such requirements.

Following are URLs where you can obtain information on other Texas Instruments products and application solutions:

<b>Products</b>		<b>Applications</b>	
Amplifiers	<a href="http://amplifier.ti.com">amplifier.ti.com</a>	Audio	<a href="http://www.ti.com/audio">www.ti.com/audio</a>
Data Converters	<a href="http://dataconverter.ti.com">dataconverter.ti.com</a>	Automotive	<a href="http://www.ti.com/automotive">www.ti.com/automotive</a>
DLP® Products	<a href="http://www.dlp.com">www.dlp.com</a>	Communications and Telecom	<a href="http://www.ti.com/communications">www.ti.com/communications</a>
DSP	<a href="http://dsp.ti.com">dsp.ti.com</a>	Computers and Peripherals	<a href="http://www.ti.com/computers">www.ti.com/computers</a>
Clocks and Timers	<a href="http://www.ti.com/clocks">www.ti.com/clocks</a>	Consumer Electronics	<a href="http://www.ti.com/consumer-apps">www.ti.com/consumer-apps</a>
Interface	<a href="http://interface.ti.com">interface.ti.com</a>	Energy	<a href="http://www.ti.com/energy">www.ti.com/energy</a>
Logic	<a href="http://logic.ti.com">logic.ti.com</a>	Industrial	<a href="http://www.ti.com/industrial">www.ti.com/industrial</a>
Power Mgmt	<a href="http://power.ti.com">power.ti.com</a>	Medical	<a href="http://www.ti.com/medical">www.ti.com/medical</a>
Microcontrollers	<a href="http://microcontroller.ti.com">microcontroller.ti.com</a>	Security	<a href="http://www.ti.com/security">www.ti.com/security</a>
RFID	<a href="http://www.ti-rfid.com">www.ti-rfid.com</a>	Space, Avionics & Defense	<a href="http://www.ti.com/space-avionics-defense">www.ti.com/space-avionics-defense</a>
RF/IF and ZigBee® Solutions	<a href="http://www.ti.com/lprf">www.ti.com/lprf</a>	Video and Imaging	<a href="http://www.ti.com/video">www.ti.com/video</a>
		Wireless	<a href="http://www.ti.com/wireless-apps">www.ti.com/wireless-apps</a>

Mailing Address: Texas Instruments, Post Office Box 655303, Dallas, Texas 75265  
Copyright © 2010, Texas Instruments Incorporated